

Installation manual

Tumble dryer

TD6–45, TD6–45SLD, TD6–60, TD6–60SLD
Type N4...



Electrolux
PROFESSIONAL

Contents

Contents

1	Safety Precautions	5
1.1	Additional safety precautions for gas heated tumble dryer	6
1.2	General safety information	6
1.3	Commercial use only	7
1.4	Copyright	7
1.5	Ergonomics certification	7
1.6	Symbols	8
2	Warranty terms and exclusions	9
3	Technical data	10
3.1	Drawing	10
3.1.1	Standard models	10
3.1.2	Models with sliding door and tilt	11
3.1.3	Models with sliding door	12
3.2	Technical data	13
3.2.1	Electric heated machines	13
3.2.2	Steam heated machines	14
3.2.3	Gas heated machines	15
3.3	Connections	16
3.4	Motor specifications	16
4	Setup	17
4.1	General	17
4.2	Unpacking	17
4.3	Recycling instruction for packaging	21
4.4	Siting	21
4.5	Mechanical installation	24
5	Installation of heating unit	25
5.1	Gas heating unit installation	25
5.2	Electric heating unit installation	36
5.3	Steam heating unit installation	44
6	Mounting equipment for sliding door	53
7	Installation of tilting unit	54
7.1	Set up	54
7.1.1	Flexible piping connection, gas heated machines	54
7.1.2	Flexible piping connection, steam heated machines	54
7.1.3	Outlet duct, all heating types	54
7.2	Contents of the tilting unit kit	55
7.3	Installation	56
8	Evacuation system	69
8.1	Air principle	69
8.2	Fresh air	70
8.3	Exhaust duct	70
8.4	Shared exhaust duct	71
8.5	Exhaust dimensioning	71
8.6	Adjusting the air flow	72
9	Electrical connection	79
9.1	Electrical installation	79
9.2	Internal connection	80
9.3	Machine connection	81
9.3.1	Three-phase connection	81
9.4	Electrical connections	82
10	Steam connection	83
10.1	Connecting the steam	83
11	Gas connection	85
11.1	Fasten the label	85
11.2	General	85
11.3	Gas installation	86
11.4	Table of pressure and adjustment	87
11.4.1	TD6-45	87
11.4.2	TD6-60	88
11.5	Test run	89
11.6	Converting instructions	90

Contents

11.6.1 Checklist.....	92
11.7 Data label.....	93
12 At first power up	94
12.1 Select language.....	94
12.2 Set time and date.....	94
12.3 Activate/Deactivate the service alarm	94
13 Function check.....	95
14 Disposal information	96
14.1 Disposal of appliance at end of life	96
14.2 Disposal of packing	96

The manufacturer reserves the right to make changes to design and component specifications.

1 Safety Precautions

- Servicing shall be carried out only by authorized personnel.
- Only authorized spare parts, accessories and consumables shall be used.
- The machine is not to be used if industrial chemicals have been used for cleaning.
- Do not dry unwashed items in the machine.
- Items that have been soiled with substances such as cooking oil, acetone, alcohol, petrol, kerosene, spot removers, turpentine, waxes and wax removers should be washed in hot water with an extra amount of detergent before being dried in the machine.
- Items such as foam rubber (latex foam), shower caps, waterproof textiles, rubber backed articles and clothes or pillows fitted with foam rubber pads should not be dried in the machine.
- Fabric softeners or similar products should be used as specified by the fabric softener instructions.
- The final part of a drying cycle occurs without heat (cool down cycle) to ensure that the items are left at a temperature that ensures that the items will not be damaged.
- Remove all objects from pockets such as lighters and matches.
- **WARNING.** Never stop the machine before the end of the drying cycle unless all items are quickly removed and spread out so that the heat is dissipated.
- Adequate ventilation has to be provided to avoid the back flow of gases into the room for appliances burning other fuels, including open fires.
- Exhaust air must not be discharged into a flue which is used for exhausting fumes from appliances burning gas or other fuels.
- The machine must not be installed behind a lockable door, a sliding door or a door with a hinge on the opposite side to that of the machine in such a way that a full opening of the machine is restricted.
- If the machine has a lint trap this has to be cleaned frequently.
- The lint must not be accumulated around the machine.
- **DO NOT MODIFY THIS APPLIANCE.**
- When performing service or replacing parts, the power must be disconnected.
- When the power is disconnected, the operator must see that the machine is disconnected (that the plug is removed and remains removed) from any point to which he has access. If this is not possible, due to the construction or installation of the machine, a disconnection with a locking system in the isolated position shall be provided.
- In accordance with the wiring rules: mount a multi-pole switch prior to the machine to facilitate installation and service operations.
- **WARNING:** The appliance must not be supplied through an external switching device, such as a timer, or connected to a circuit that is regularly switched on and off by a utility.
- If different rated voltages or different rated frequencies (separated by a /) are stated at the machine data plate, instructions for adjusting the appliance for operation at the required rated voltage or rated frequency are stated in the installation manual.
- Stationary appliances not fitted with means for disconnection from the supply mains having a contact separation in all poles that provide full disconnection under overvoltage category III, means for disconnection must be incorporated in the fixed wiring in accordance with the wiring rules.
- The openings in the base, shall not be obstructed by a carpet.

- Oil-affected items can ignite spontaneously, especially when exposed to heat sources such as in a tumble dryer. The items become warm, causing an oxidation reaction in the oil. Oxidation creates heat. If the heat cannot escape, the items can become hot enough to catch fire. Piling, stacking or storing oil-affected items can prevent heat from escaping and so create a fire hazard.
- If it is unavoidable that fabrics that contain vegetable or cooking oil or have been contaminated by hair care products be placed in a tumble dryer they should first be washed in hot water with extra detergent – this will reduce, but not eliminate, the hazard.
- Maximum mass of dry cloth: TD6–45: 50 kg, TD6–60: 67 kg.
- A-weighted emission sound pressure level at working stations: < 70 dB(A).
- Additional requirements for the following countries; AT, BE, BG, HR, CY, CZ, DK, EE, FI, FR, DE, GR, HU, IS, IE, IT, LV, LT, LU, MT, NL, NO, PL, PT, RO, SK, SI, ES, SE, CH, TR, UK:
 - CAUTION: This appliance shall not be installed where the public has access.
- Additional requirements for other countries:
 - This appliance is not intended for use by persons (including children) with reduced physical, sensory or mental capabilities, or lack of experience and knowledge, unless they have been given supervision or instruction concerning use of the appliance by a person responsible for their safety. Children should be supervised to ensure that they do not play with the appliance.

1.1 Additional safety precautions for gas heated tumble dryer

- Before installation, check that the local distribution conditions, nature of gas and pressure and the adjustment of the appliance are compatible.
- The machine is not to be installed in rooms containing cleaning machines with perchloroethylene, TRICHLOROETHYLENE or CHLOROFLUOROCONTAINING HYDROCARBONS as cleaning agents.
- NOTE: it is pointed out that the connection and commissioning of appliances complying with this standard are subject to observance of the installation regulations in force in the countries where these appliances are marketed.
- Connection to the appliance shall be made with a flexible hose suitable for the appliance category in accordance with national installation regulations of the country of destination and that in case of doubt the installer shall contact the supplier.
- The appliance should be installed on non-flammable materials for the floor, worktop and/or wall close to the appliance if required.
- If you can smell gas:
 - Do not switch on any equipment
 - Do not use electrical switches
 - Do not use telephones in the building
 - Evacuate the room, building or area
 - Contact the person responsible for the machine

1.2 General safety information

In order to prevent damage to the electronics (and other parts) that may occur as the result of condensation, the machine should be placed in room temperature for 24 hours before being used for the first time.

1.3 Commercial use only

The machine/machines covered by this manual is/are made for commercial and industrial use only.

1.4 Copyright

This manual is intended solely for consultation by the operator and can only be given to third parties with the permission of Electrolux Professional AB company.

1.5 Ergonomics certification

The human body is designed for movement and activity but physical stress injuries as a result of static and repetitive movements or unfavorable working postures may occur.

The ergonomic features of your product, the ones which may influence your physical and cognitive interaction with it, have been assessed and certified.

A product which exhibits ergonomic features, in fact, shall fulfil specific ergonomic requirements, belonging to three different areas: Polytechnic, Biomedical and Psychosocial (usability and satisfaction).







For each of these areas, specific tests with real users have been performed. The product was therefore compliant with the ergonomic acceptability criteria requested by the standards.

In case several machines are managed by the same operator the repetitive movements will increase and as a consequence of this the related biomechanical risk will increase exponentially.

Follow the below recommendations to avoid, as much as possible, operators acquiring bodily injury.

- Make sure there are suitable trolleys or baskets for loading, unloading and transportation.
- Organize job rotation in the working place in the case several machines are managed by the same operator.
- When using the operating panel: Increase the distance from the machine by taking steps back before looking up at the display.
- To avoid injuries to the back when opening/closing the filter door, the operators should, as far as possible, bend their knees instead of their backs.
- While the operators lift the filter door, they should reduce the distance between the feet and the handles as much as possible and flex their legs instead of their backs.
- When loading and unloading:
Reduce as much as possible the picking distance. If a trolley is used; avoid the trolley being positioned between the operator and the machine.
If the operator needs to raise the arm above shoulder height, he/she should reduce the number of objects handled during each picking operation.

1.6 Symbols

	Caution
	Caution, hot surface
	Caution, high voltage
	Warning, risk of fire / flammable material
	Danger, crush hazard
	Read the instructions before using the machine

2 Warranty terms and exclusions

If the purchase of this product includes warranty coverage, warranty is provided in line with local regulations and subject to the product being installed and used for the purposes as designed, and as described within the appropriate equipment documentation.

Warranty will be applicable where the customer has used only genuine spare parts and has performed maintenance in accordance with Electrolux Professional user and maintenance documentation made available in paper or electronic format.

Electrolux Professional strongly recommends using Electrolux Professional approved cleaning, rinse and descaling agents to obtain optimal results and maintain product efficiency over time.

The Electrolux Professional warranty does not cover:

- service trips cost to deliver and pick up the product;
- installation;
- training on how to use/operate;
- replacement (and/or supply) of wear and tear parts unless resulting from defects in materials or workmanship reported within one (1) week from the failure;
- correction of external wiring;
- correction of unauthorized repairs as well as any damages, failures and inefficiencies caused by and/or resulting from;
 - insufficient and/or abnormal capacity of the electrical systems (current/voltage/frequency, including spikes and/or outages);
 - inadequate or interrupted water supply, steam, air, gas (including impurities and/or other that does not comply with the technical requirements for each appliance);
 - plumbing parts, components or consumable cleaning products that are not approved by the manufacturer;
 - customer's negligence, misuse, abuse and/or non-compliance with the use and care instructions detailed within the appropriate equipment documentation;
 - improper or poor: installation, repair, maintenance (including tampering, modifications and repairs carried out by third parties not authorized third parties) and modification of safety systems;
 - Use of non-original components (e.g.: consumables, wear and tear, or spare parts);
 - environment conditions provoking thermal (e.g. overheating/freezing) or chemical (e.g. corrosion/oxidation) stress;
 - foreign objects placed in- or connected to- the product;
 - accidents or force majeure;
 - transportation and handling, including scratches, dents, chips, and/or other damage to the finish of the product, unless such damage results from defects in materials or workmanship and is reported within one (1) week of delivery unless otherwise agreed;
- product with original serial numbers that have been removed, altered or cannot be readily determined;
- replacement of light bulbs, filters or any consumable parts;
- any accessories and software not approved or specified by Electrolux Professional.

Warranty does not include scheduled maintenance activities (including the parts required for it) or the supply of cleaning agents unless specifically covered within any local agreement, subject to local terms and conditions.

Check on Electrolux Professional website the list of authorized customer care.

3 Technical data

3.1 Drawing

3.1.1 Standard models

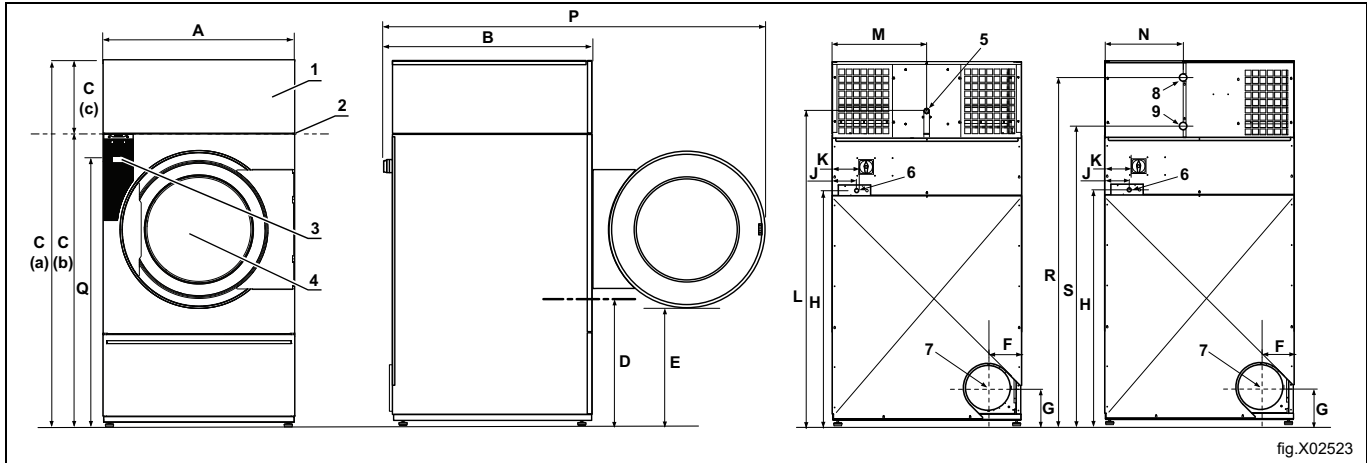

fig.X02523

1	Heating unit
2	Delivery height, excl. 100 mm packaging
3	Operating panel
4	Door opening, \varnothing 940 mm
5	Gas connection
6	Electric connection
7	Exhaust duct
8	Steam inlet
9	Steam return

mm	A	B	C (a)	C (b)	C (c)	D	E	F
TD6-45	1290	1215	2465	1965	500	850	790	230
TD6-60	1290	1405	2465	1965	500	850	790	230

mm	G	H	J	K	L	M	N	P
TD6-45	245	1590	165	180	2055	660	530	2400
TD6-60	245	1590	165	180	2055	660	530	2590

mm	Q	R	S
TD6-45	1868	2350	2060
TD6-60	1868	2350	2060

3.1.2 Models with sliding door and tilt

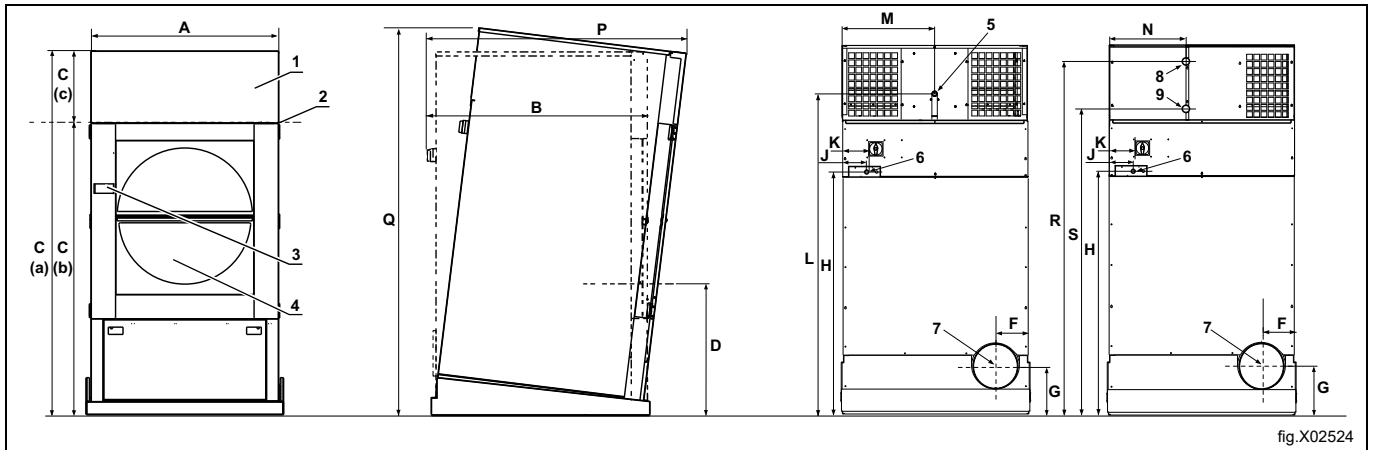

fig.X02524

1	Heating unit
2	Delivery height, excl. 100 mm packaging
3	Operating panel
4	Door opening, \varnothing 940 mm
5	Gas connection
6	Electric connection
7	Exhaust duct
8	Steam inlet
9	Steam return

mm	A	B	C (a)	C (b)	C (c)	D	E	F
TD6-45	1320	1305	2550	2045	500	930	—	230
TD6-60	1320	1495	2550	2045	500	930	—	230

mm	G	H	J	K	L	M	N	P
TD6-45	330	1670	165	180	2130	660	530	1550
TD6-60	330	1670	165	180	2130	660	530	1750

mm	Q	R	S
TD6-45	2660	2425	2130
TD6-60	2680	2425	2130

3.1.3 Models with sliding door

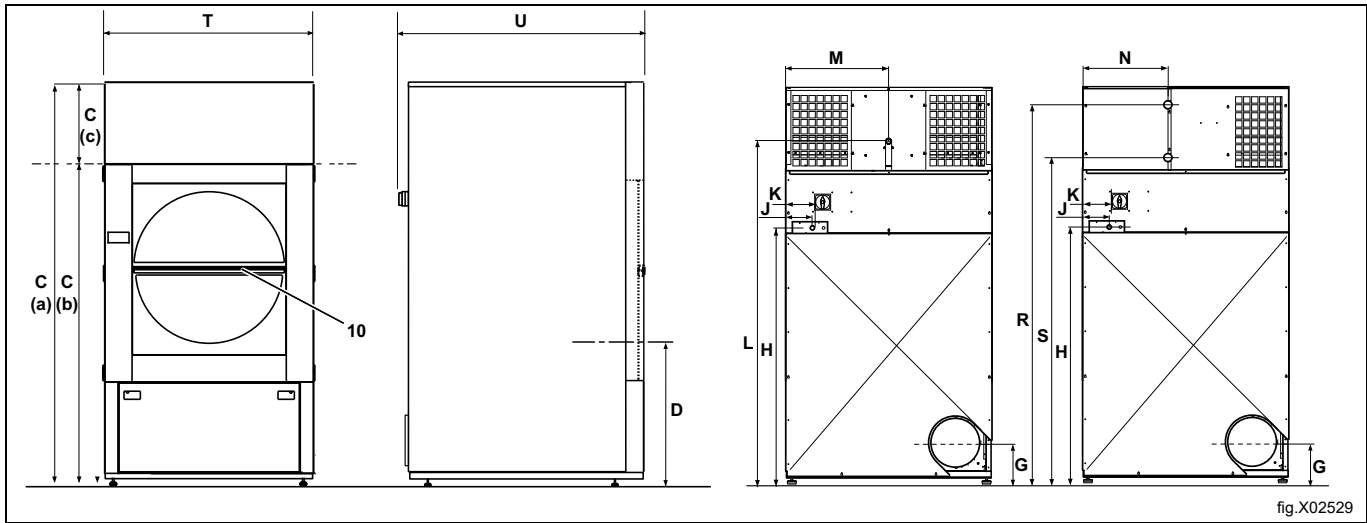

fig.X02529

10 | Door opening with sliding door, \varnothing 940 mm

mm	C (a)	C (b)	C (c)	D
TD6-45	2465	1965	500	845
TD6-60	2465	1965	500	845

mm	G	H	J	K	L	M	N
TD6-45	245	1590	165	180	2055	660	530
TD6-60	245	1590	165	180	2055	660	530

mm	Q	R	S	T	U
TD6-45	1868	2350	2060	1314	1300
TD6-60	1868	2350	2060	1314	1490

3.2 Technical data

3.2.1 Electric heated machines

		TD6-45	TD6-60
Weight, standard machine	kg	440	470
Weight, with sliding door	kg	494	524
Weight, with sliding door and tilt	kg	546	576
Weight, heating unit, electric	kg	42	42
Weight, tilting unit	kg	66	66
Drum volume	litres	900	1200
Drum diameter	mm	1240	1240
Drum depth	mm	770	1000
Drum speed, medium load	rpm	38	38
Rated capacity, filling factor 1:18 (Max. load)	kg	50	67
Rated capacity, filling factor 1:20 (Recommended load)	kg	45	60
Input rating	kW	48/60	60/72
Sound power/pressure level at drying*	dB(A)	< 70	< 70
Heat emission of installed power, max	%	15	15

* Sound power levels measured according to ISO 60704.

Air flow data

		TD6-45		TD6-60	
		STD ¹	SLD ²	STD ¹	SLD ²
Optimum air flow, 60 kW, 50 Hz**	m ³ /h	1815	2145	—	—
Optimum air flow, 72 kW, 50 Hz**	m ³ /h	—	—	1782	—
Optimum static back pressure, 60 kW, 50 Hz**	Pa	435	150	—	—
Maximum static back pressure, 60 kW, 50 Hz**	Pa	540	220	—	—
Optimum static back pressure, 72 kW, 50 Hz**	Pa	—	—	1120	—
Maximum static back pressure, 72 kW, 50 Hz**	Pa	—	—	1170	—

1. Standard machine
2. Machine with sliding door

** In a cold empty machine.

3.2.2 Steam heated machines

		TD6-45	TD6-60
Weight, standard machine	kg	440	470
Weight, with sliding door	kg	494	524
Weight, with sliding door and tilt	kg	546	576
Weight, heating unit, steam	kg	50	50
Weight, tilting unit	kg	66	66
Drum volume	litres	900	1200
Drum diameter	mm	1240	1240
Drum depth	mm	770	1000
Drum speed, medium load	rpm	38	38
Rated capacity, filling factor 1:18 (Max. load)	kg	50	67
Rated capacity, filling factor 1:20 (Recommended load)	kg	45	60
Input rating At 700 kPa	kW	60	80
Steam pressure	kPa	100–1000	100–1000
Sound power/pressure level at drying*	dB(A)	< 70	< 70
Heat emission of installed power, max	%	15	15

* Sound power levels measured according to ISO 60704.

Air flow data

		TD6-45		TD6-60	
		STD ¹	SLD ²	STD ¹	SLD ²
Optimum air flow, 50 Hz**	m ³ /h	1804	—	2178	2178
Optimum static back pressure, 50 Hz**	Pa	490	—	640	640
Maximum static back pressure, 50 Hz**	Pa	570	—	710	750

1. Standard machine

2. Machine with sliding door

** In a cold empty machine.

3.2.3 Gas heated machines

		TD6-45	TD6-60
Weight, standard machine	kg	440	470
Weight, with sliding door	kg	494	524
Weight, with sliding door and tilt	kg	546	576
Weight, heating unit, gas	kg	39	46
Weight, tilting unit	kg	66	66
Drum volume	litres	900	1200
Drum diameter	mm	1240	1240
Drum depth	mm	770	1000
Drum speed, medium load	rpm	38	38
Rated capacity, filling factor 1:18 (Max. load)	kg	50	67
Rated capacity, filling factor 1:20 (Recommended load)	kg	45	60
Input rating ¹ Natural gas (GNH)	kW m ³ /h	63 6.00	84 8.00
Input rating ¹ Propane (LPG)	kW m ³ /h	63 2.37	83 3.12
Sound power/pressure level at drying*	dB(A)	< 70	< 70
Heat emission of installed power, max	%	15	15

1. Referring to gross calorific value.

* Sound power levels measured according to ISO 60704.

Note!

This default gas appliance is built to run on natural gas (group I2H and I2E), commonly identified by GNH. Japan to run on LPG (group I3B/P) 2800 Pa inlet pressure, no regulation.

This default gas appliance is built to be installed at not over than 610 m (2001 ft) high altitude otherwise a kit for high altitude must be installed to the machine. For the kit No. please refer to the spare parts list.

Air flow data

		TD6-45		TD6-60	
		STD ¹	SLD ²	STD ¹	SLD ²
Optimum air flow, 50 Hz**	m ³ /h	1815	—	2068	1914
Optimum air flow, 60 Hz**	m ³ /h	1518	—	2321	—
Optimum static back pressure, 50 Hz**	Pa	350	—	900	940
Optimum static back pressure, 60 Hz**	Pa	1230	—	150	—
Maximum static back pressure, 50 Hz**	Pa	460	—	980	1030
Maximum static back pressure, 60 Hz**	Pa	1300	—	260	—

1. Standard machine

2. Machine with sliding door

** In a cold empty machine.

3.3 Connections

		TD6-45	TD6-60
Air outlet	∅ mm	315	315
Gas connection	1"	ISO 7/1-R1	ISO 7/1-R1
Steam inlet/outlet		ISO 228/1-G1	ISO 228/1-G1

3.4 Motor specifications

		TD6-45	TD6-60
Blower motor 3-phase, effect	kW	1.1	1.1
50 Hz	rpm	2800	2800
60 Hz	rpm	3400	3400
Drum motor 3-phase, effect	kW	1.5	1.5
50 Hz	rpm	1440	1440
60 Hz	rpm	1730	1730

4 Setup

4.1 General

The principle work flow to setup or install this machine is as follows:

1. Unpacking
2. Positioning/siting, levelling or/and securing the machine.
3. Heating unit installation
4. Tilting unit installation (option)
5. Correcting the fresh air/air intake's size, exhaust duct's size and pipe(s) connections in considering a stand-alone machine or sharing exhaust duct.
6. Electric connections, connect the power supply to the machine.
7. Air flow or static back pressure adjustments in a cold empty machine in considering a stand-alone machine or sharing exhaust duct.
8. Gas connection, gas converting, high altitude kit installation. (For gas heated machine).
9. Function check.
10. Option functions check.

More details are described in each part of this installation manual.

4.2 Unpacking

Note!

The procedure when unpacking the machine is the same on machines with standard door and with sliding door. The following pictures shows a machine with standard door except from the sections relating to sliding door.

Note!

Two persons are recommended for the unpacking.

The heating unit is separated from the top of the machine from the factory and delivered as a separate package. The top panel for the heating unit is placed on top of the machine and the rest of the material are placed in the rear area of the machine.

Demount the rear panels and the filter door.

Carefully remove the top panel for the heating unit which is placed on top of the machine and the rest of the material from the rear area of the machine.

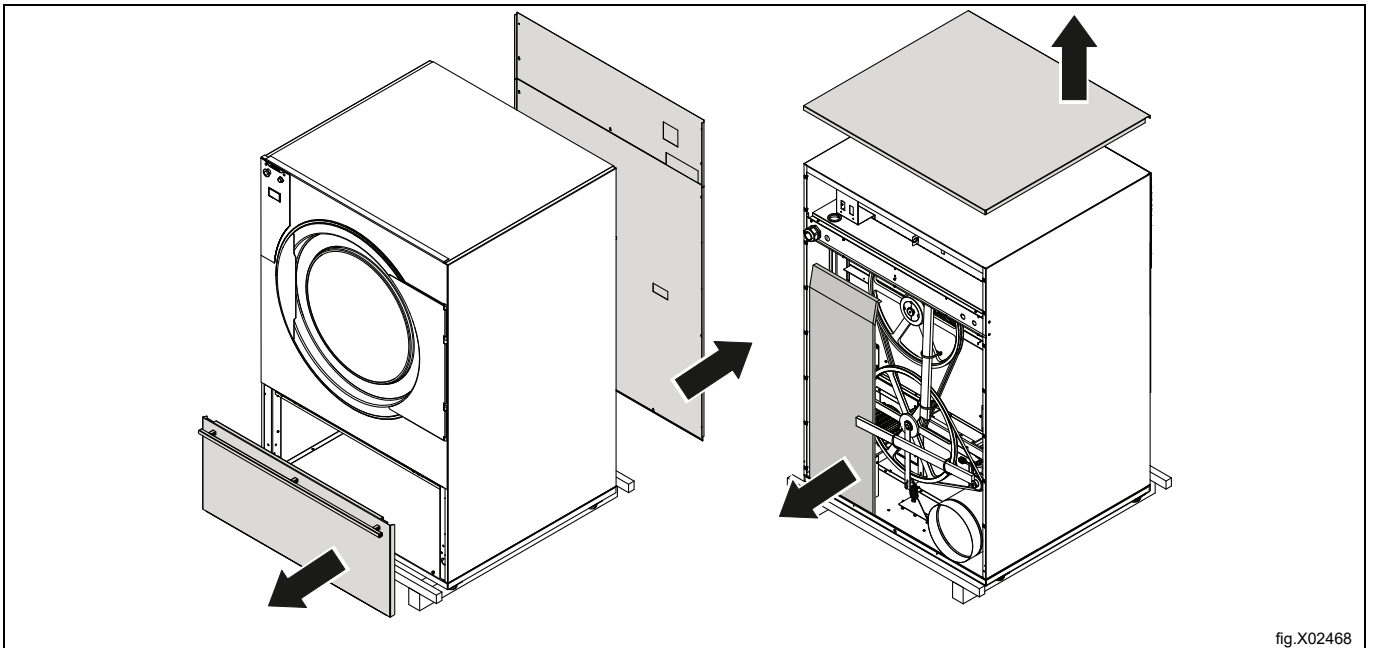
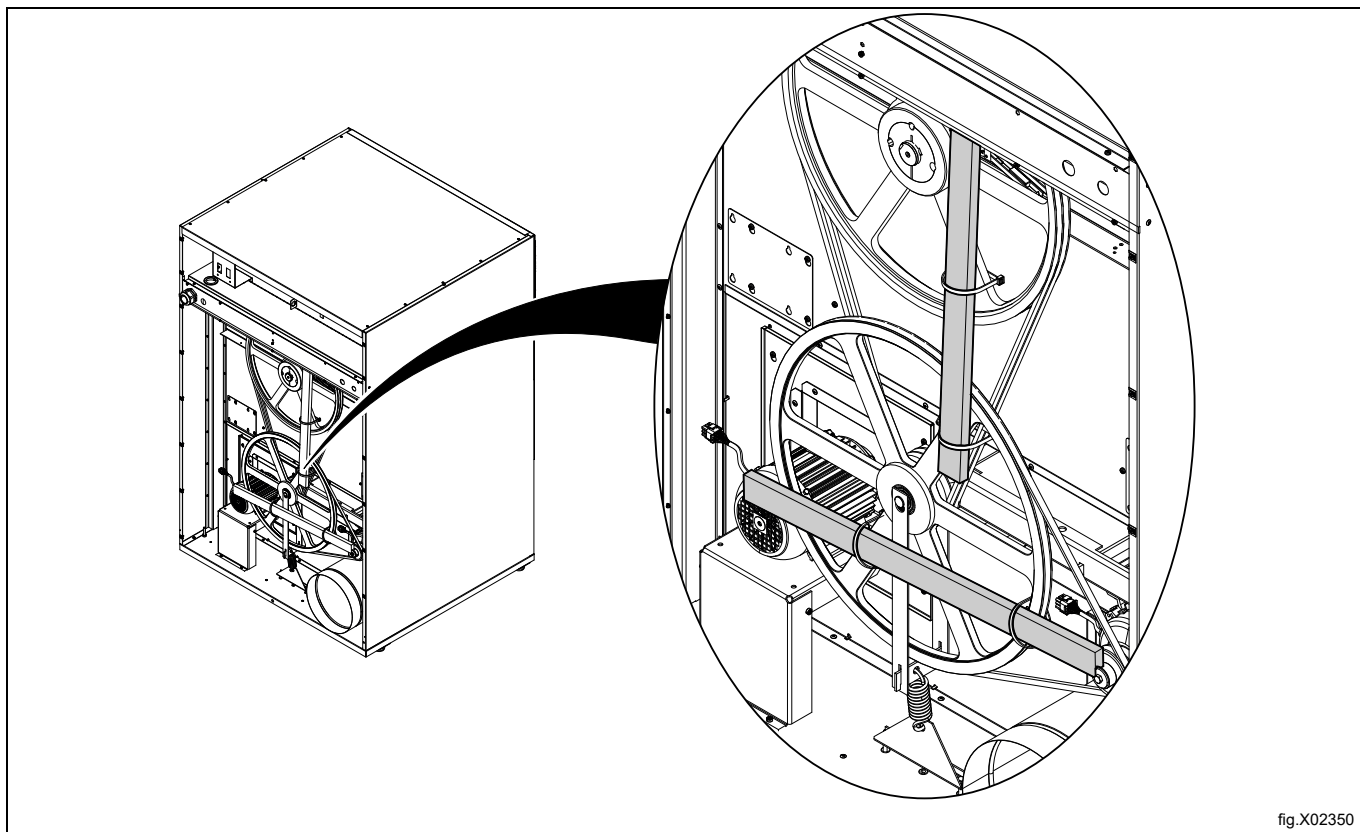
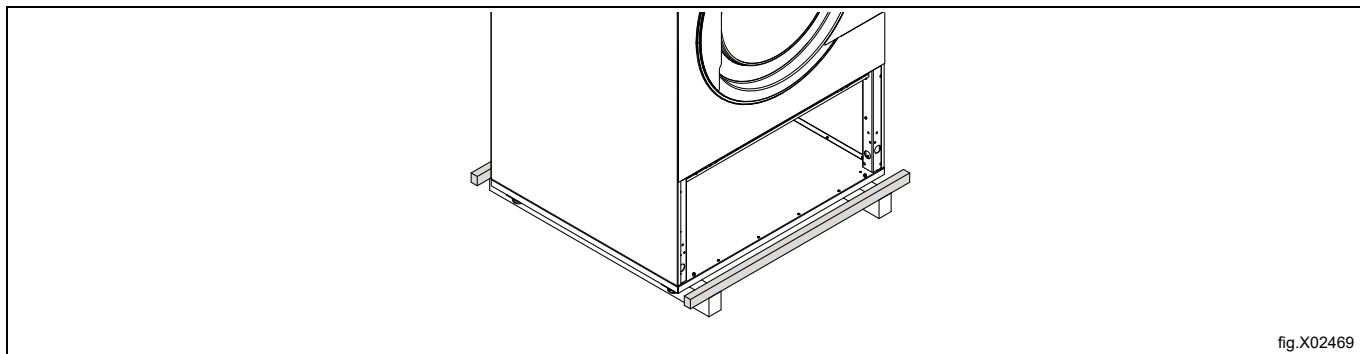

fig.X02468

Cut the straps and carefully remove the wooden bars, used as transport securities, from the rear of the machine.



Remove the two wooden bars, one in the front and one in the back.



Remove the bolts between the machine and pallet.

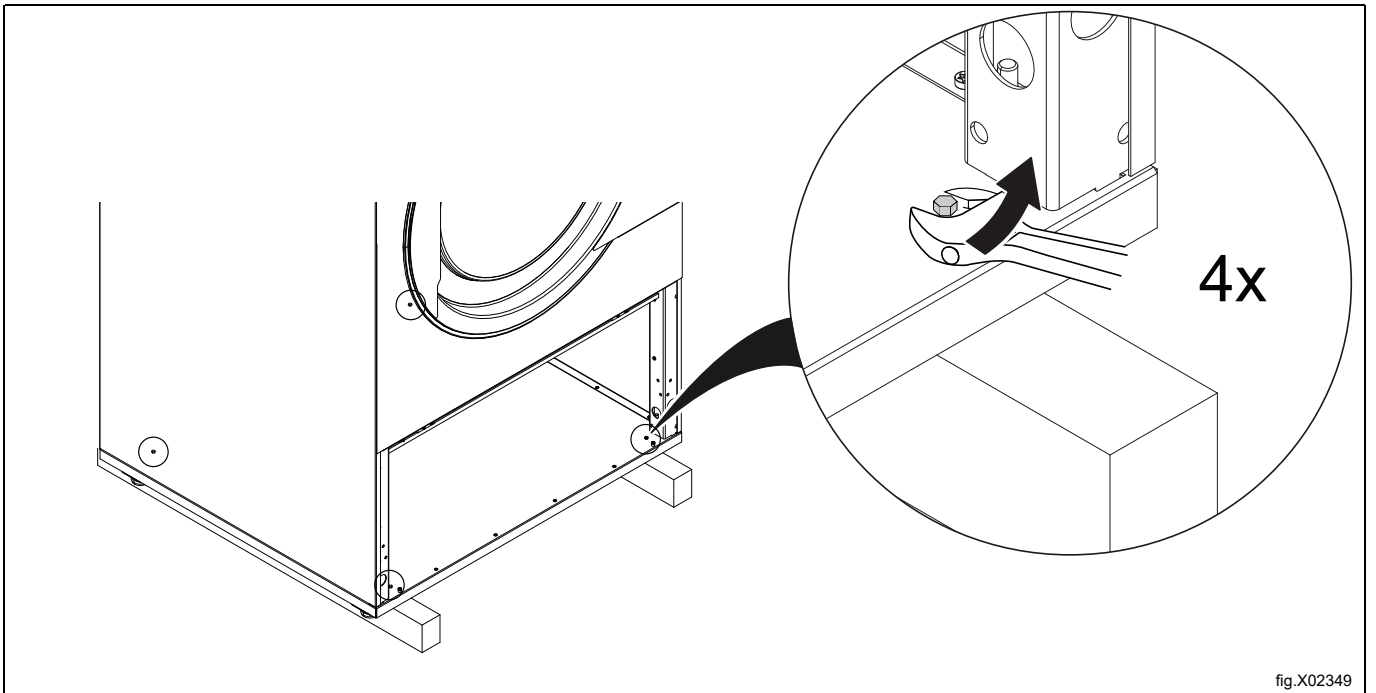

Lift the machine with for example a fork-lift truck and remove the wooden bars.

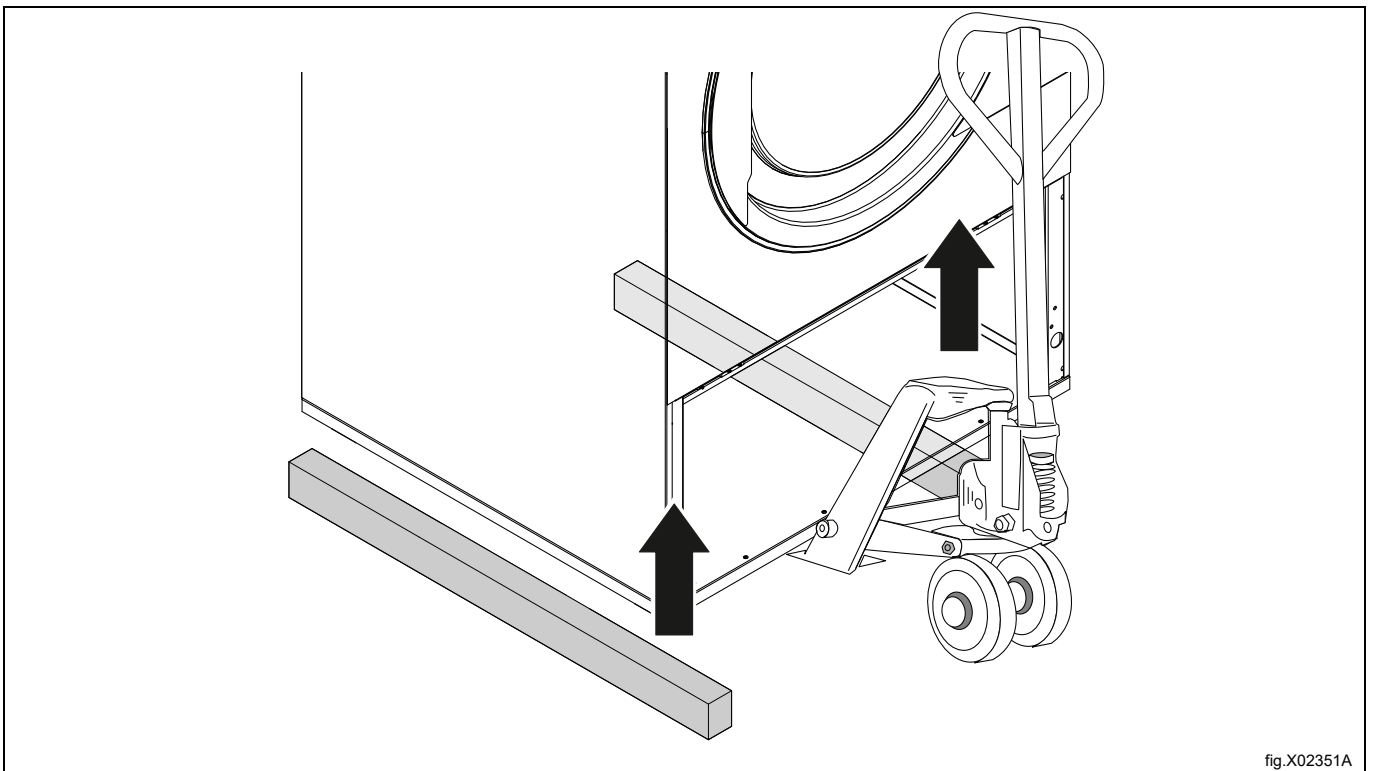

Mount the four feet attached with the machine in the bottom bearers.

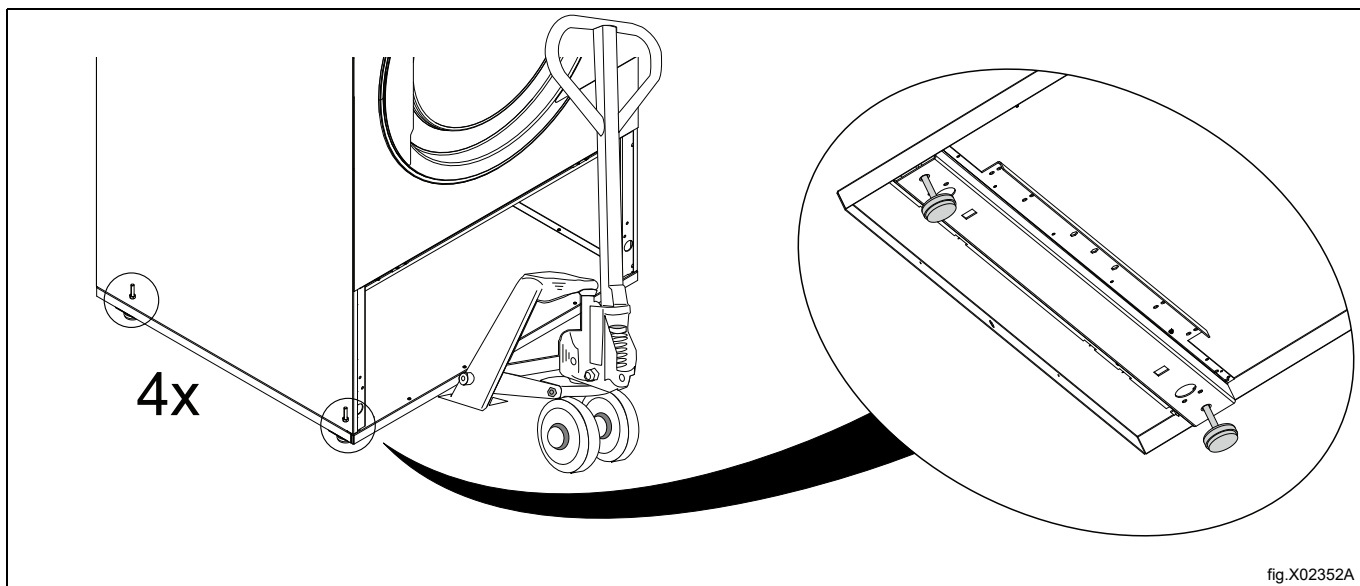

When the fork-lift truck is removed the two remaining support sections are disengaged.

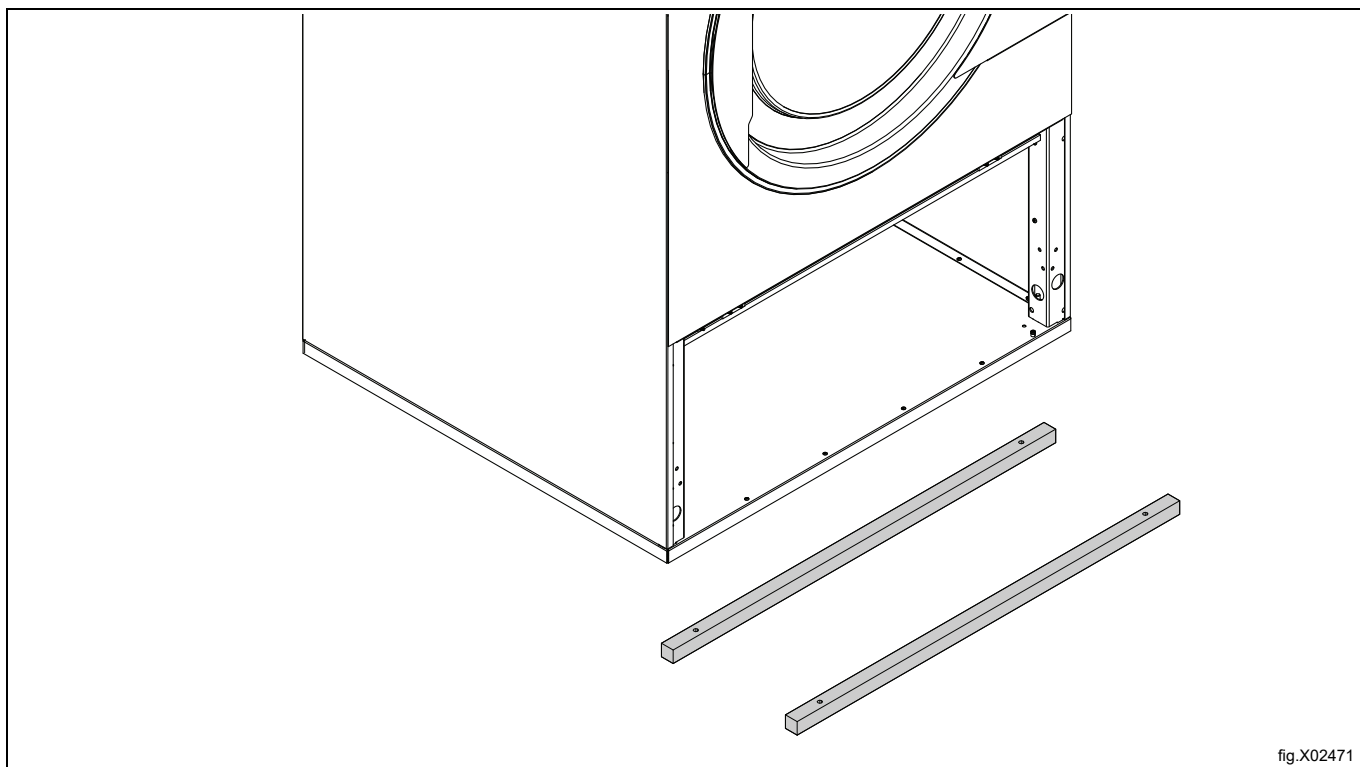

Place the machine on its final position, please refer to the section [Siting](#).

4.3 Recycling instruction for packaging

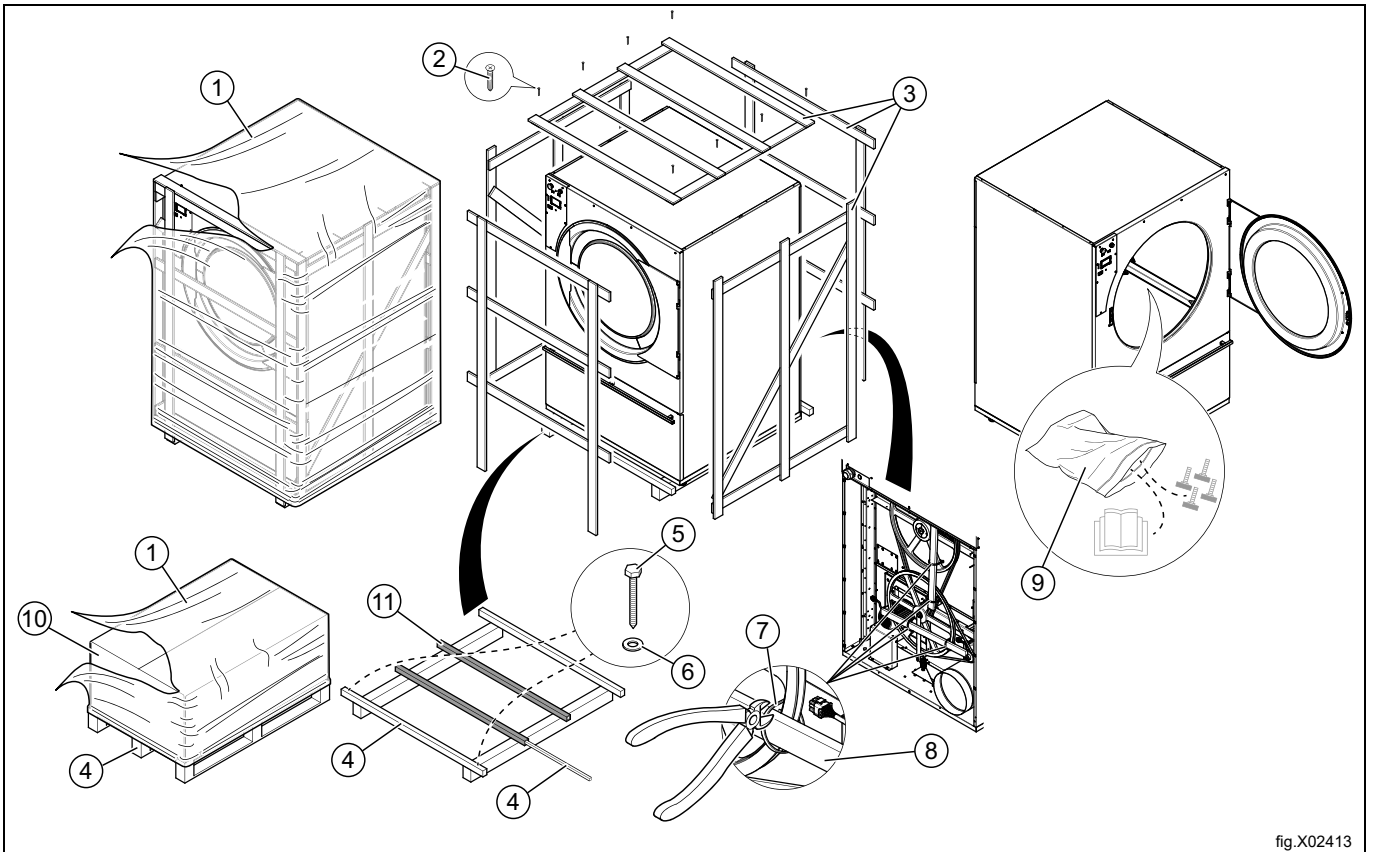

fig.X02413

Fig.	Description	Code	Type
1	Wrapping film	LDPE 4	Plastics
2	Screw	FE 40	Steel
3	Packaging	FOR 50	Wood
4	Pallet	FOR 50	Wood
5	Screw	FE 40	Steel
6	Washer	FE 40	Steel
7	Cable Tie		Nylon
8	Transport security	FOR 50	Wood
9	Plastic bag	PET 1	Plastics
10	Cardboard packaging	PAP 20	Paper
11	Steel sections	FE 40	Steel

4.4 Siting

Place the machine on its final position.

The figure shows recommended distance to walls and / or other machines.

Standard machine

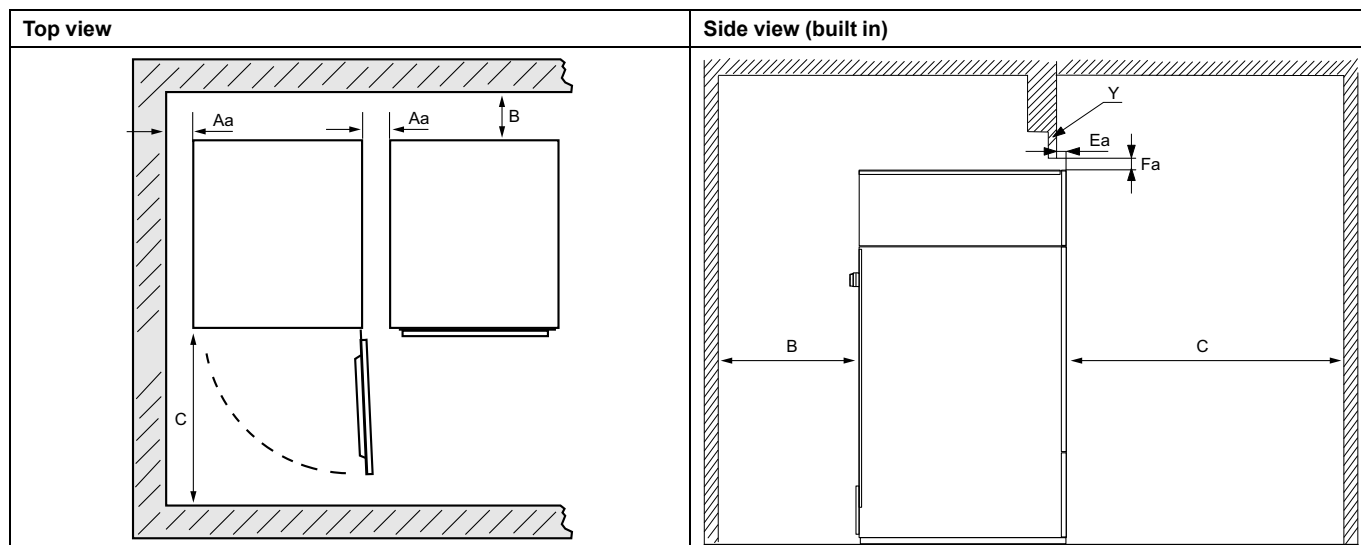

Aa	≥ 10 mm
B	≥ 500 mm (Min. 200 mm)
C	≥ 1250 mm
Ea	≥ 40 mm
Fa	≥ 25 mm (The overhead soffit may be used to close the gap above the machine. Min. required clearance: 0 mm)
Y	For built-in machines it is recommended that the wall section Y is a removable finish piece.

Machine with Sliding door / Sliding door and tilt

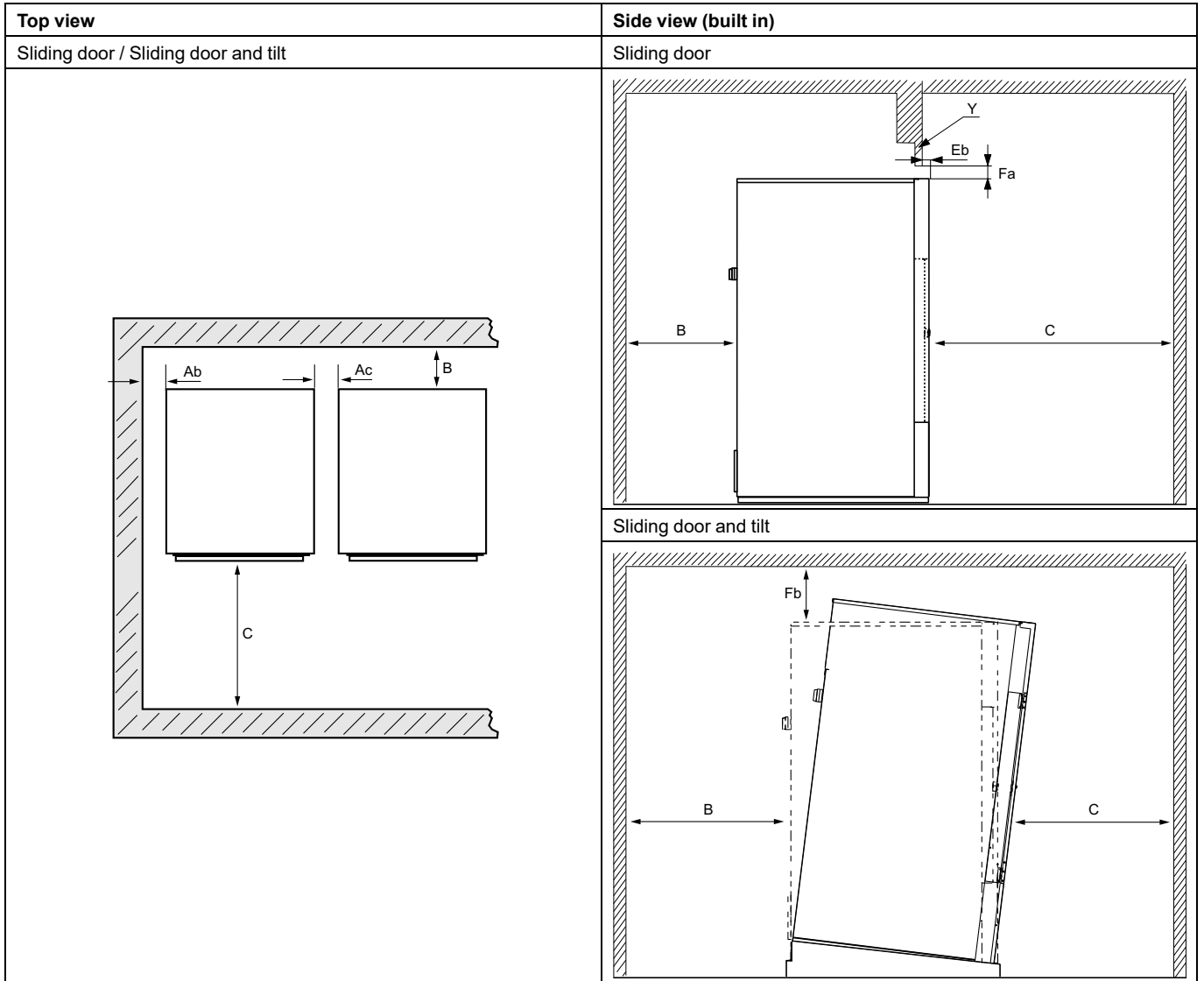

Ab	≥ 50 mm
Ac	≥ 100 mm
B	≥ 500 mm (Min. 200 mm)
C	≥ 1250 mm
Eb	≥ 120 mm
Fa	≥ 25 mm (The overhead soffit may be used to close the gap above the machine. Min. required clearance: 0 mm)
Fb	≥ 200 mm
Y	For built-in machines it is recommended that the wall section Y is a removable finish piece.

Note!

The machine should be positioned so that there will be enough space for working, both for the user and service personnel.

Respecting the given recommendations will provide easy access for maintenance and service operations.

In case of space limitations, it is possible to install machines without respecting to the given recommendations. If so, keep in mind that it might be necessary to disconnect and move other machines to be able to reach and perform service on affected machine.

4.5 Mechanical installation

Level the machine with the feet of the machine. (The height adjustment must be as low as possible).

The maximum height adjustment of the feet is 70 mm and is only to be used cautiously while removing the fork truck (if a fork truck has been used).

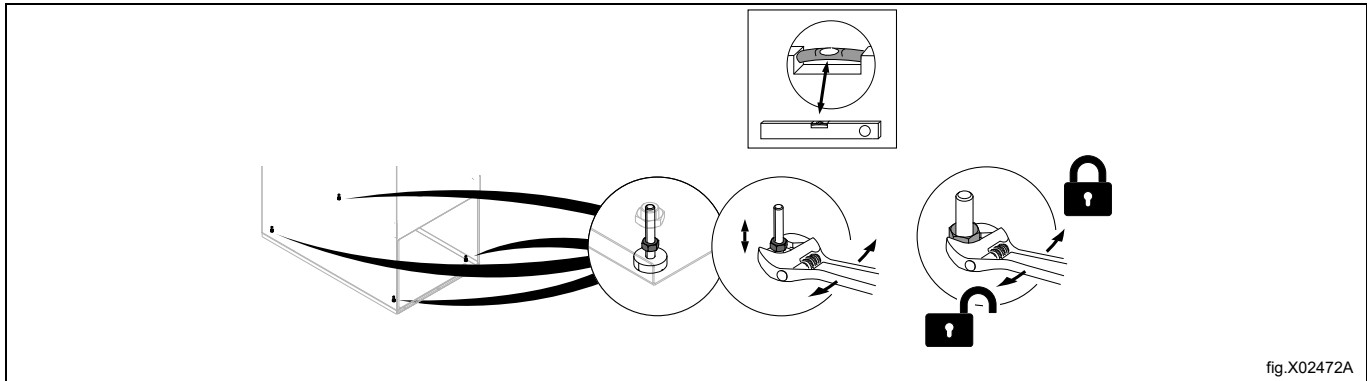

For further instructions on how to install the heating unit, please refer to the section [Installation of heating unit](#).

5 Installation of heating unit

Note!

The procedure when mounting the heating unit is the same on machines with standard door and with sliding door. The following pictures shows a standard door except from pages relating specifically to sliding door.

Heating unit

The heating unit is to be mounted on top of the machine.

It is recommended that the mounting is carried out by two persons.

Use the supplied screws.

5.1 Gas heating unit installation

Put the gas heating unit in position on top of the machine.

The weight of the gas heating unit is approximately 29 kg / 64 lbs.

The gas heating unit shall be lifted according to the illustration. Be careful not to damage any parts.

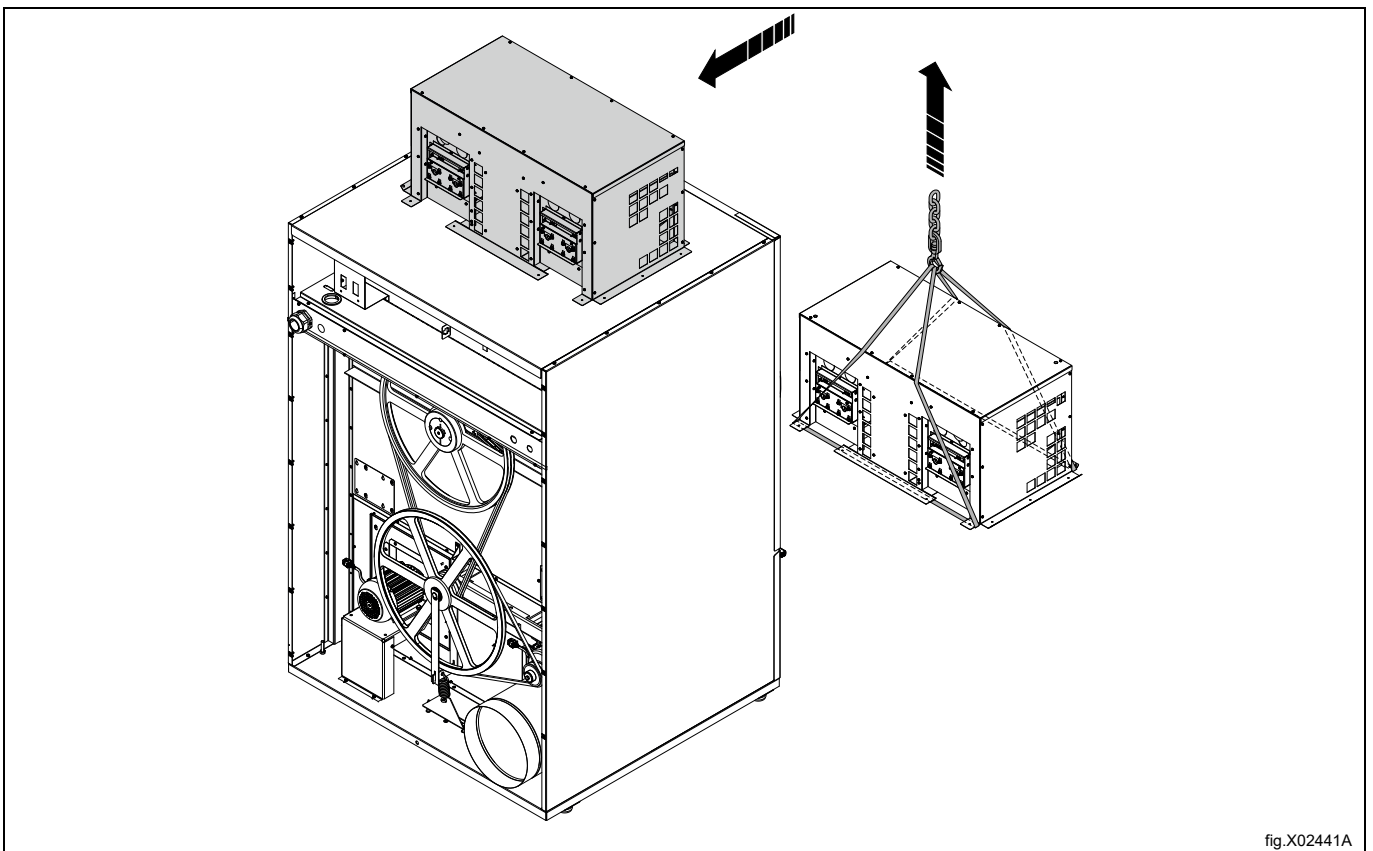
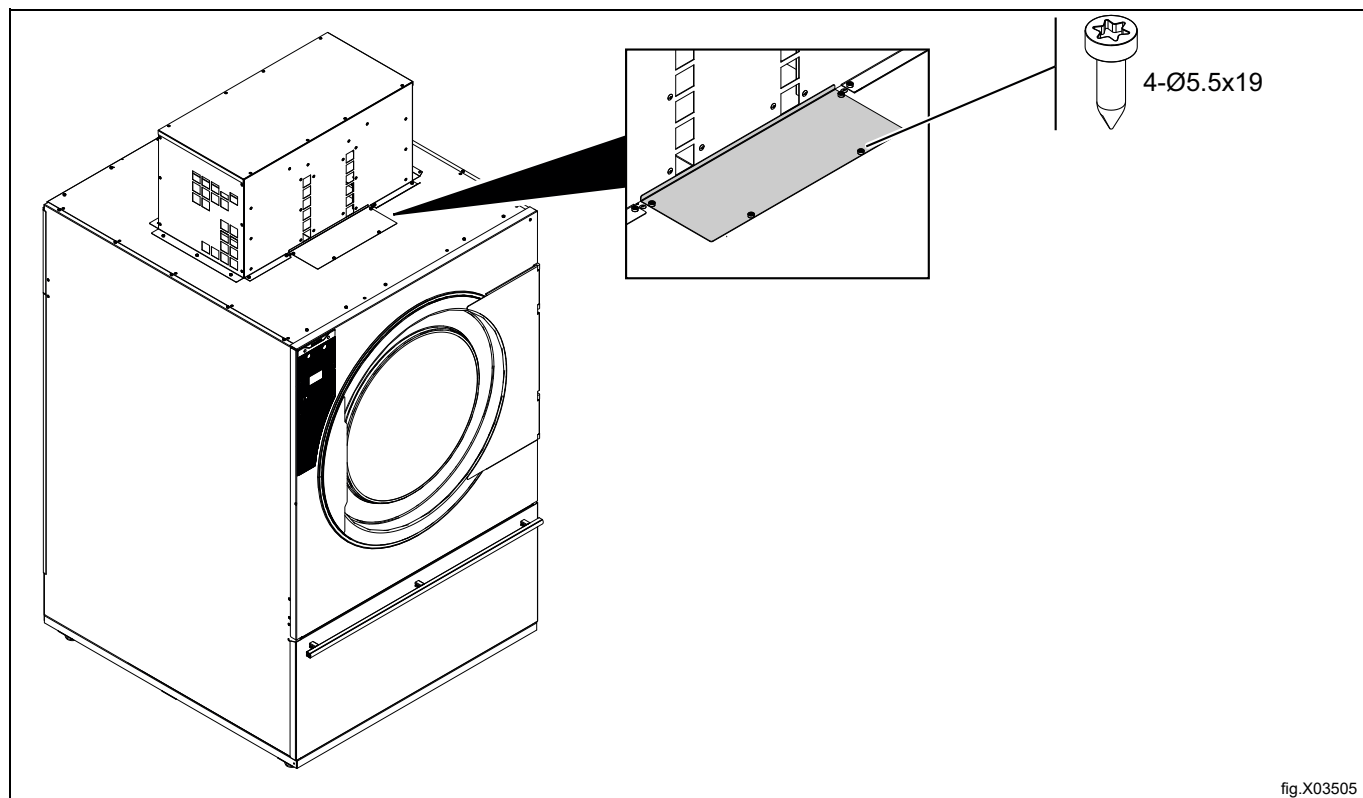

fig.X02441A

For TD6-60 only:

- Mount the panel at the front of the machine.



Fasten the gas heating unit on the machine.

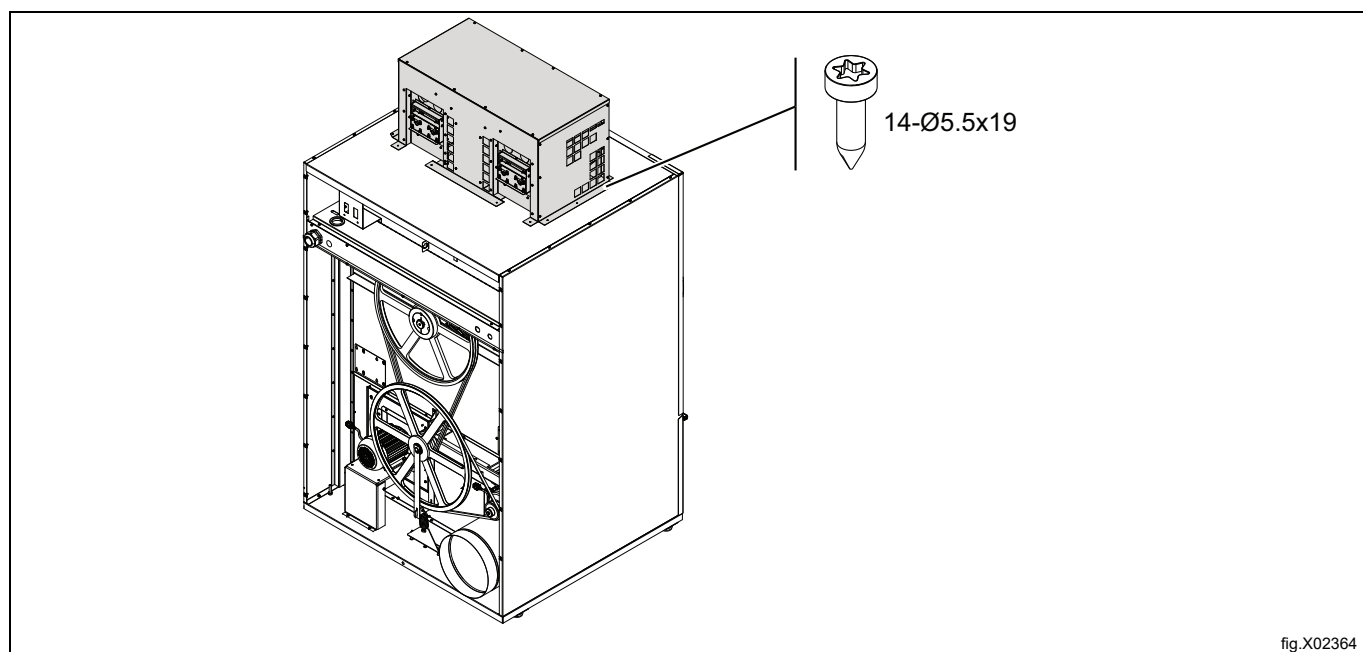

Fasten the bracket.

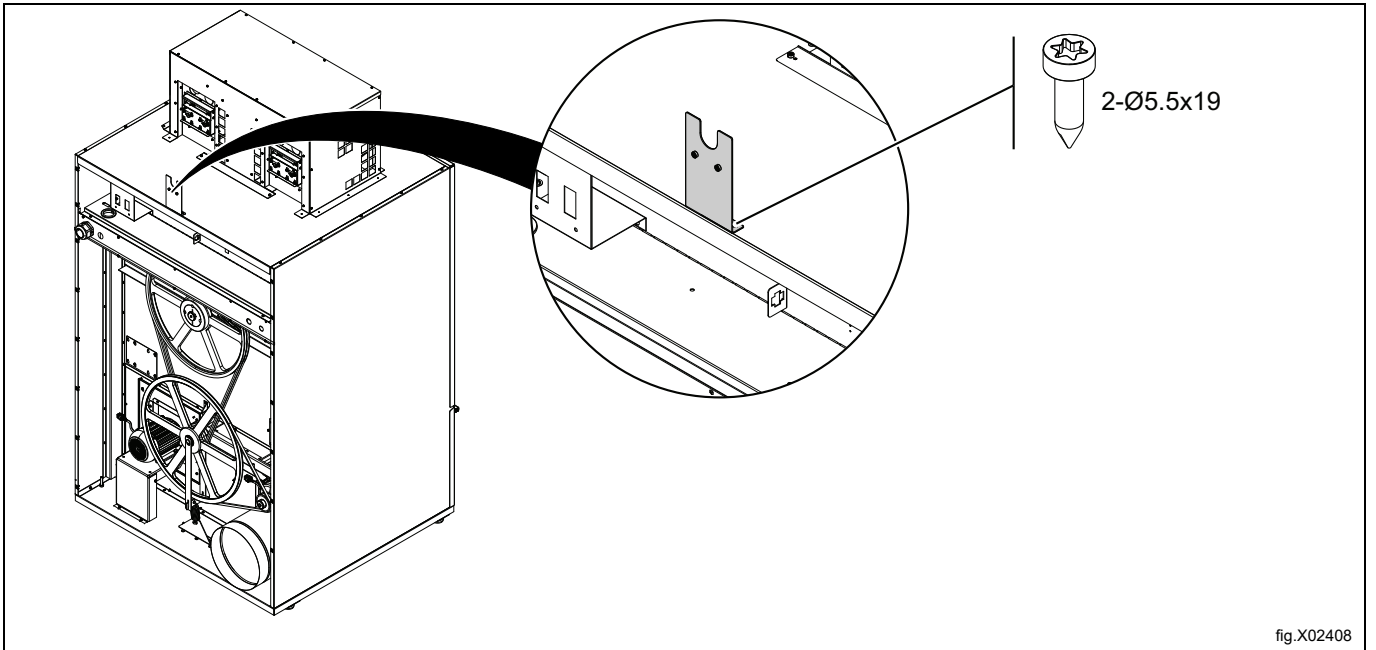

If the machine is to be converted to another gas type, do the gas converting before this step. Please refer to the section: "Converting instructions".

Insert the gas nozzles by positioning the gas pipe unit on the bracket. Make sure to mount the grommet to protect the gas pipe.

When the gas pipe unit is in position, fasten the lower bracket with three screws on the gas heating unit.

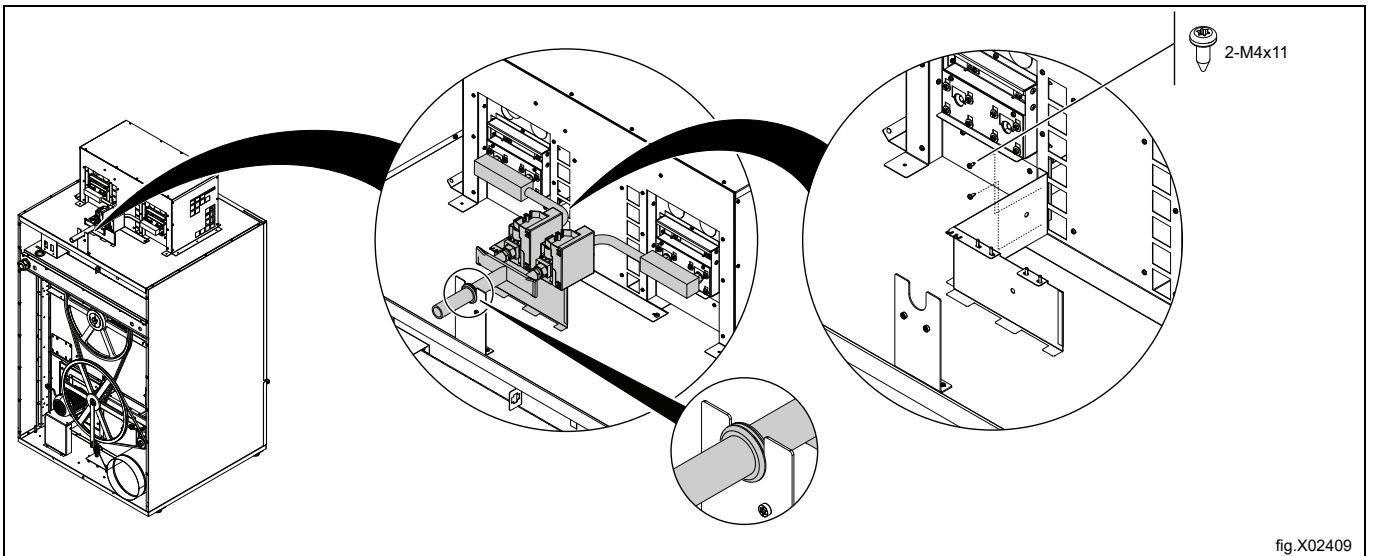

Lock the nozzles by pushing the bracket (A) on the gas heating unit upwards until the screw holes are visible (B) and then fasten the two screws. This is to be made on both sides of the gas pipe unit.

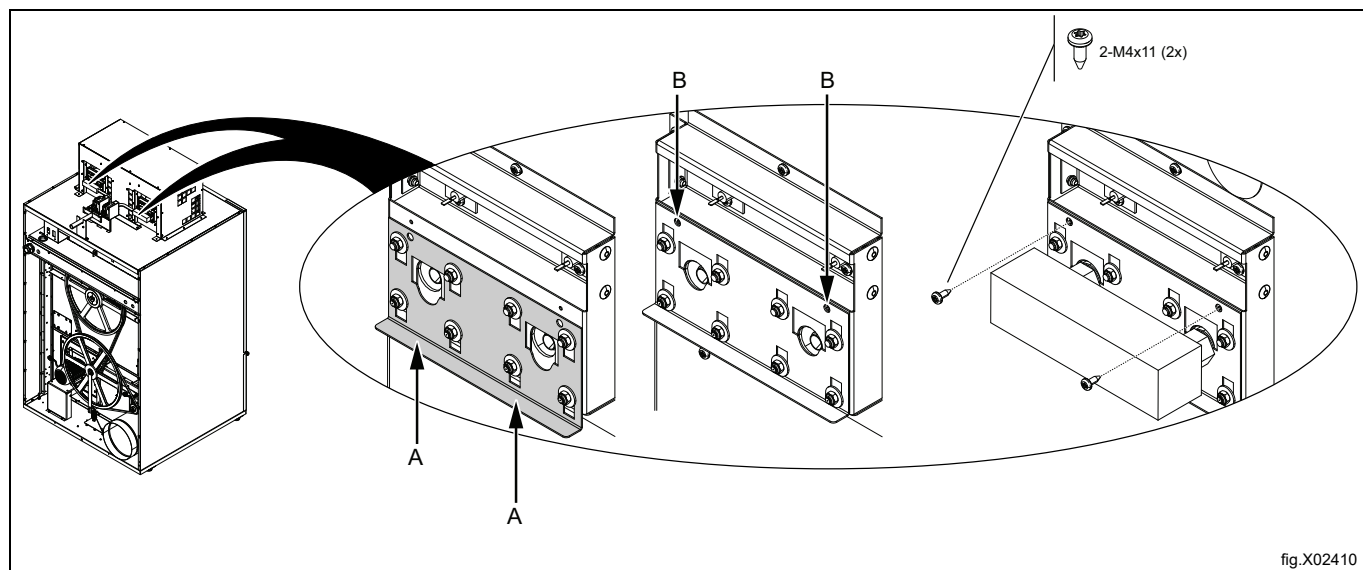

Make sure all cables are lead up through the machine.
Connect the ignition cable (B) and the ionization wire (A).

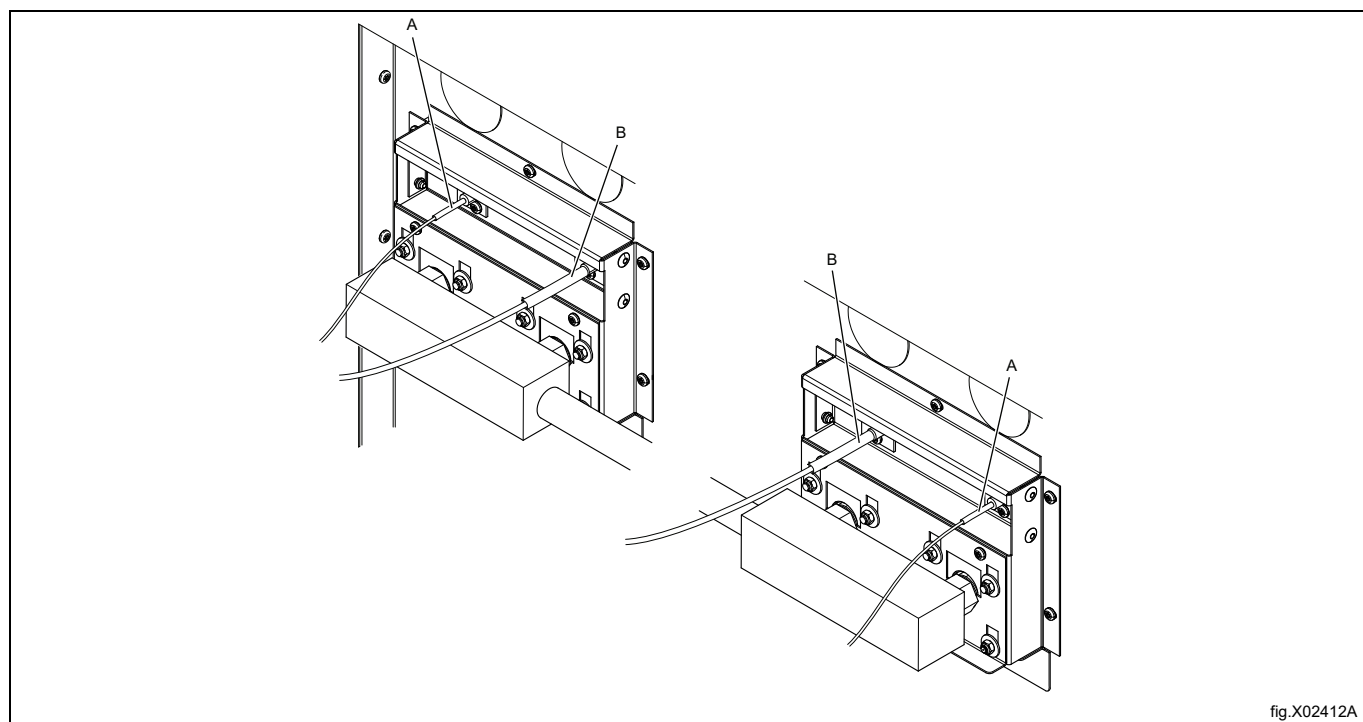

Connect the ground cable to the support bracket.

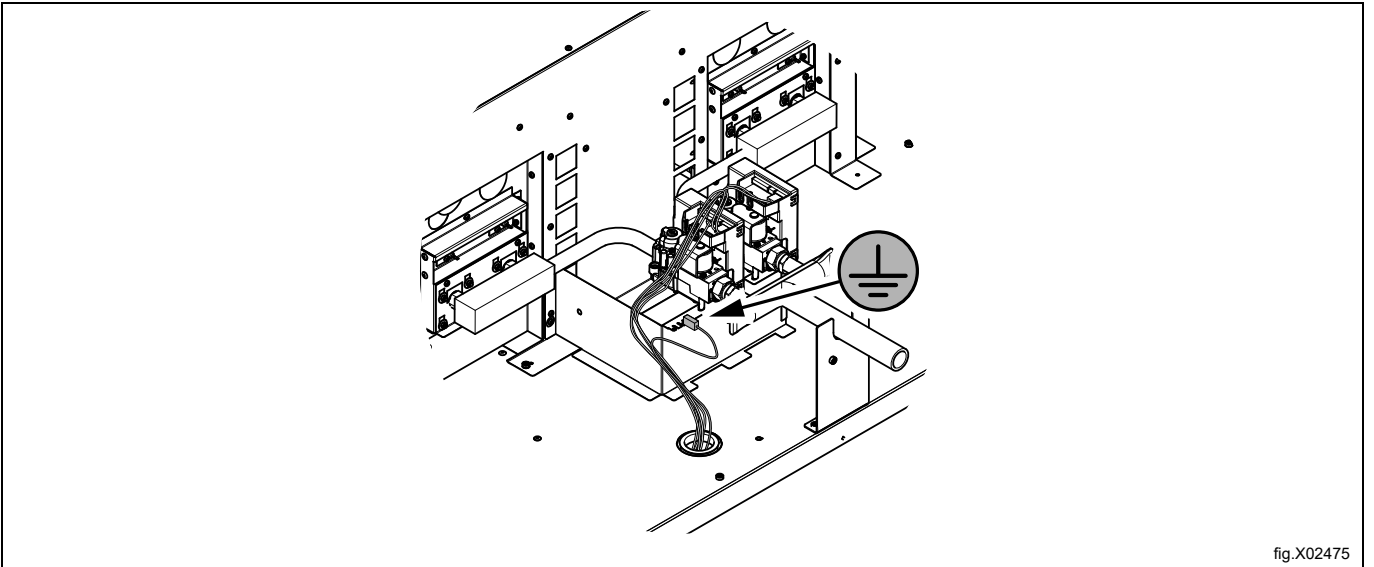

Mount the brace.

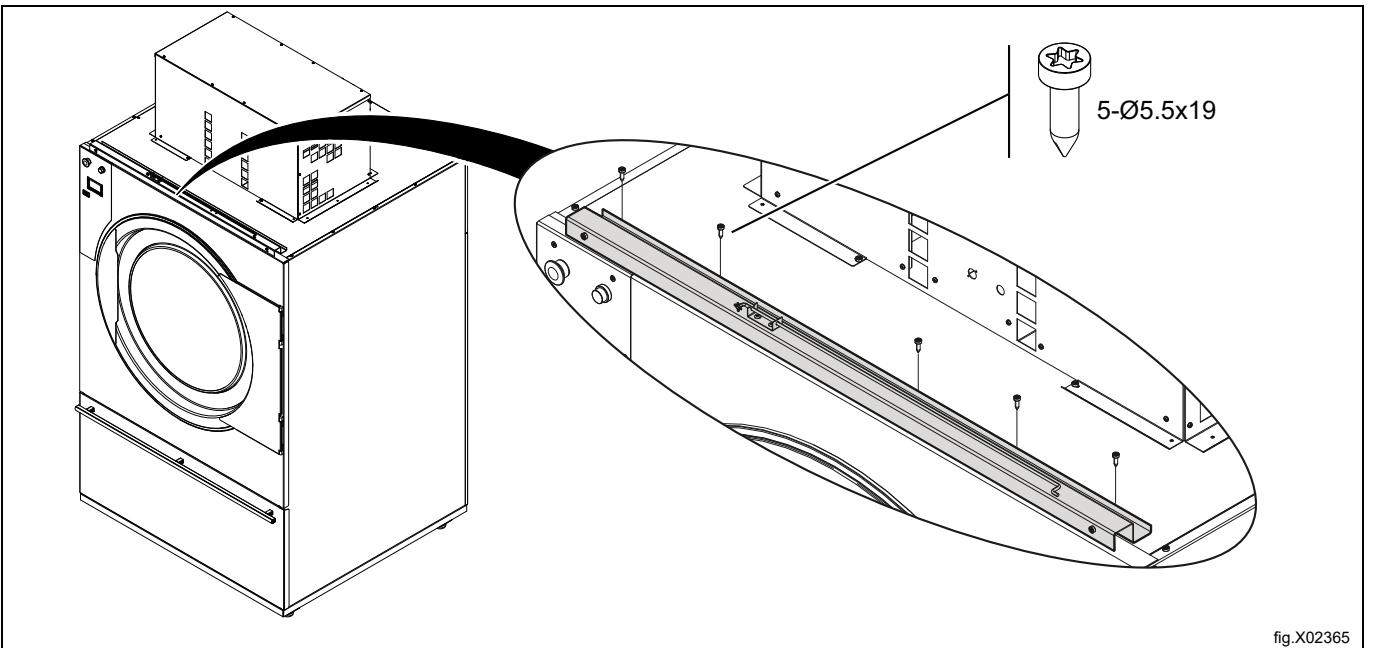

If the machine has sliding door, go to section [Mounting equipment for sliding door](#), before carrying out the next step.

Mount the side panels using 5 screws on each side as follows:

First fasten the front screw and the back screw but not all the way down. Turn the side panel with the grooves facing downward and mount the side panel in the grooves. Tighten the screws.

Fasten the last 3 screws.

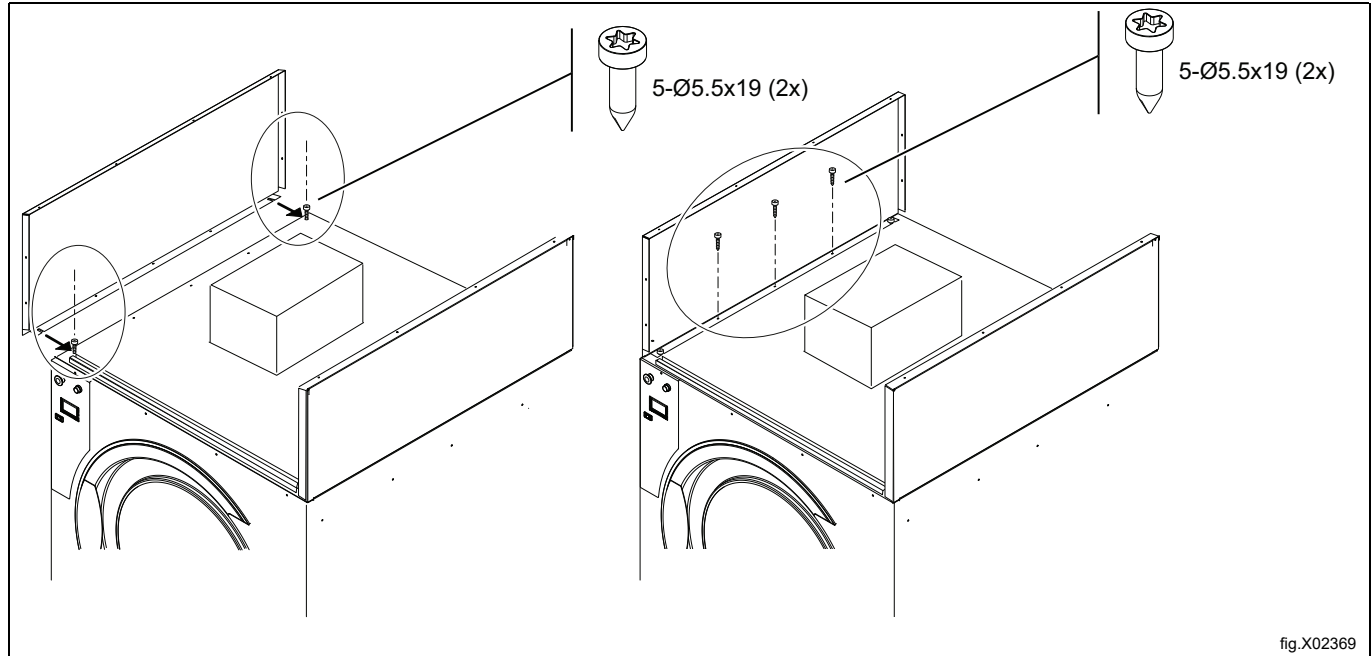

Mount the air mazes.

On the side of air mazes and panels, pre-mount the screws (1) through the panels to the air mazes. Fasten the screws (2).

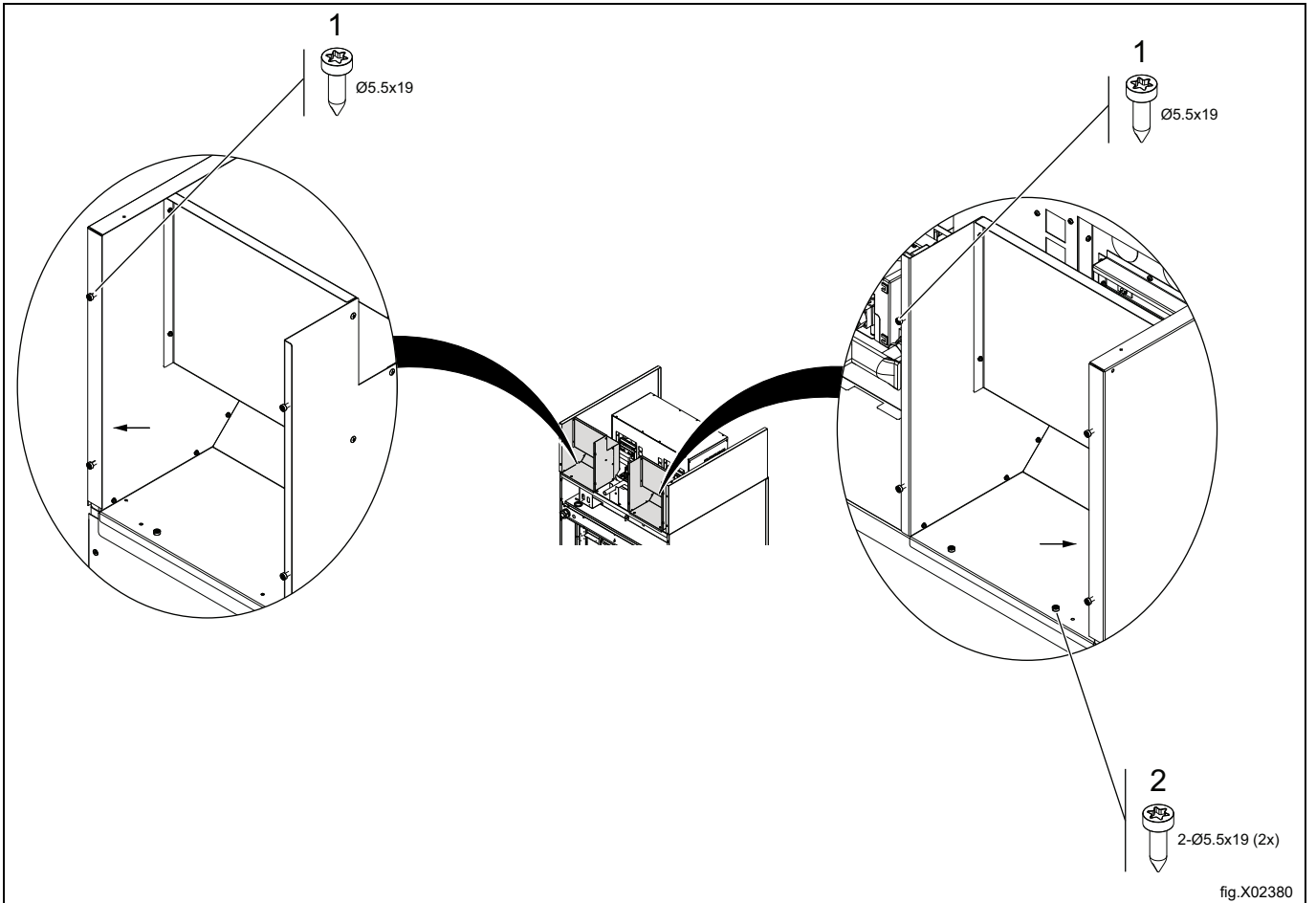

fig.X02380

Put the top panel in position but do not fasten it.

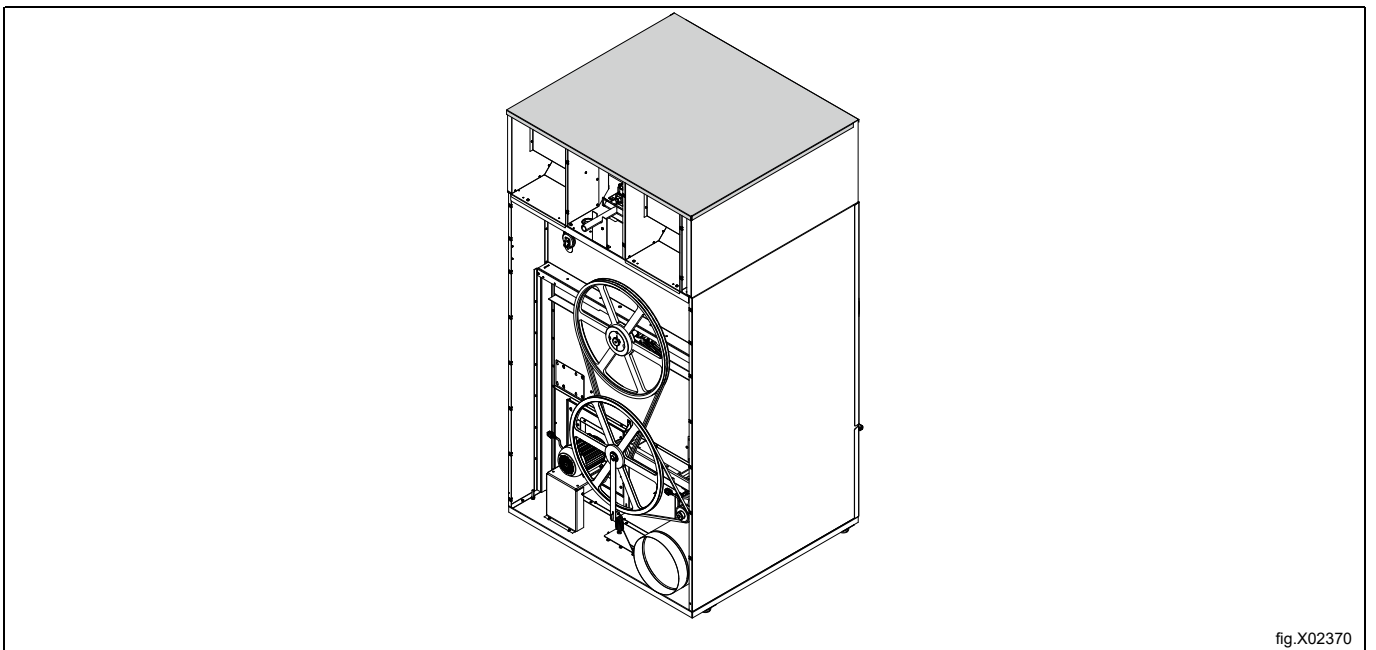

fig.X02370

Lead the multiple plug from the gas control down through the cable gland (D) to the component unit and place it in connector marked *B*. Strap the wires according to the figure.

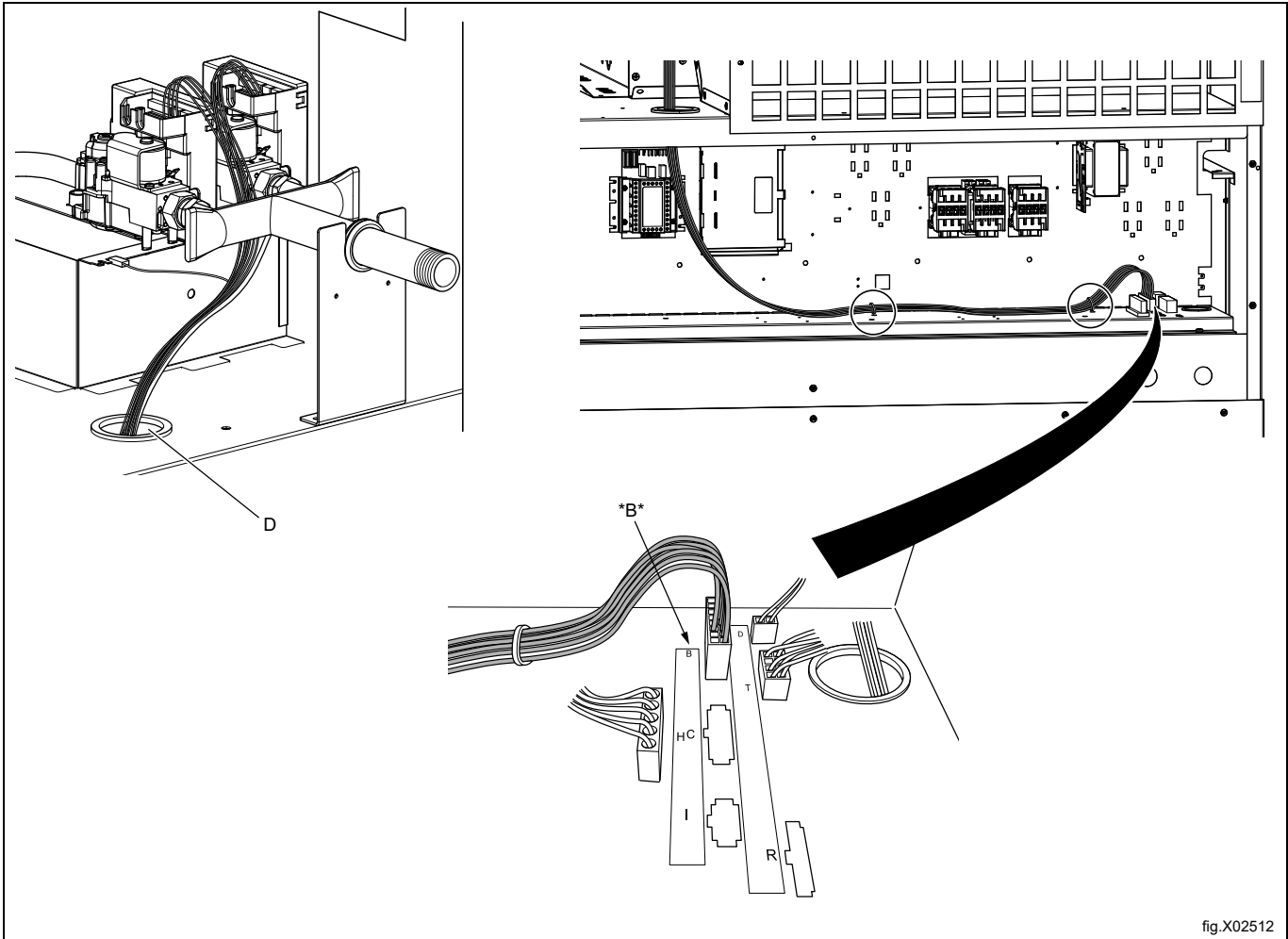

fig.X02512

Pre-mount the panels to the air mazes.

Note!

Do not fasten the middle panel before the Test run is performed.

Fasten the top panel.

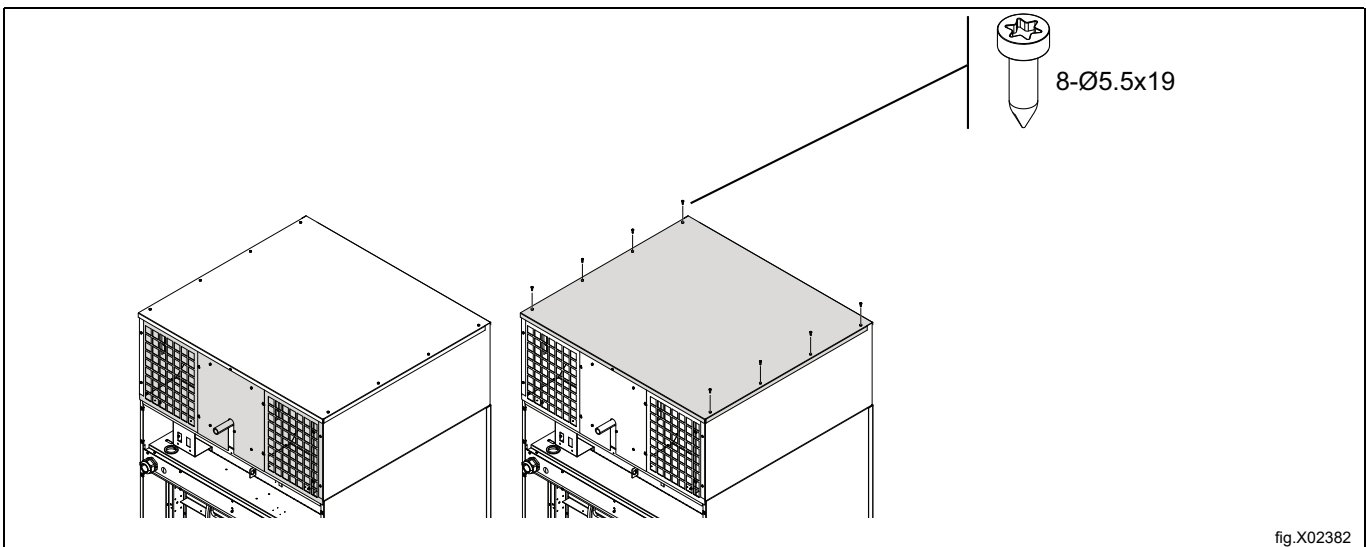

fig.X02382

Mount the support plate (C).

Mount the front panel with 2 screws (3a) and locking nuts (3b) on the sides.

Close the front panel and fasten it with 2 screws on the front.

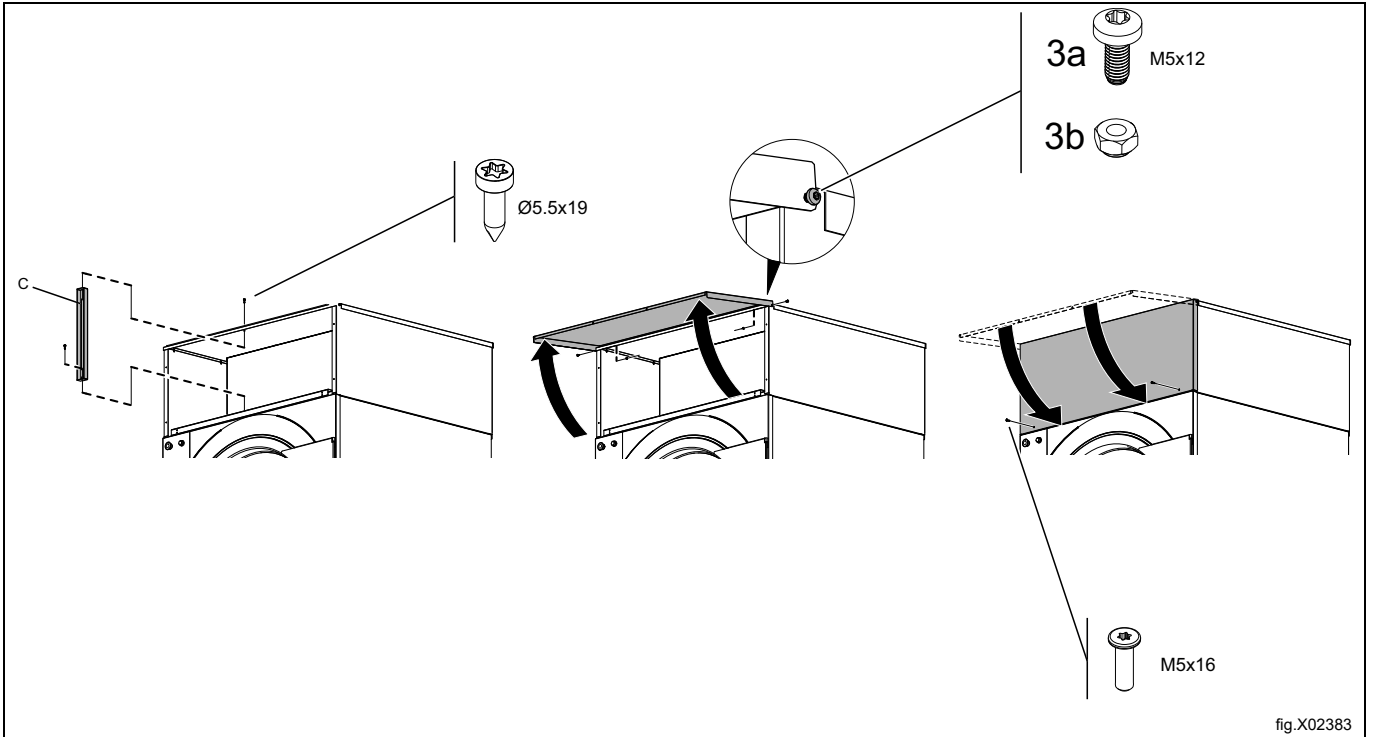

fig.X02383

Place the supply disconnecter panel with handle in its place.

For more information, see section "[Electrical connection](#)".

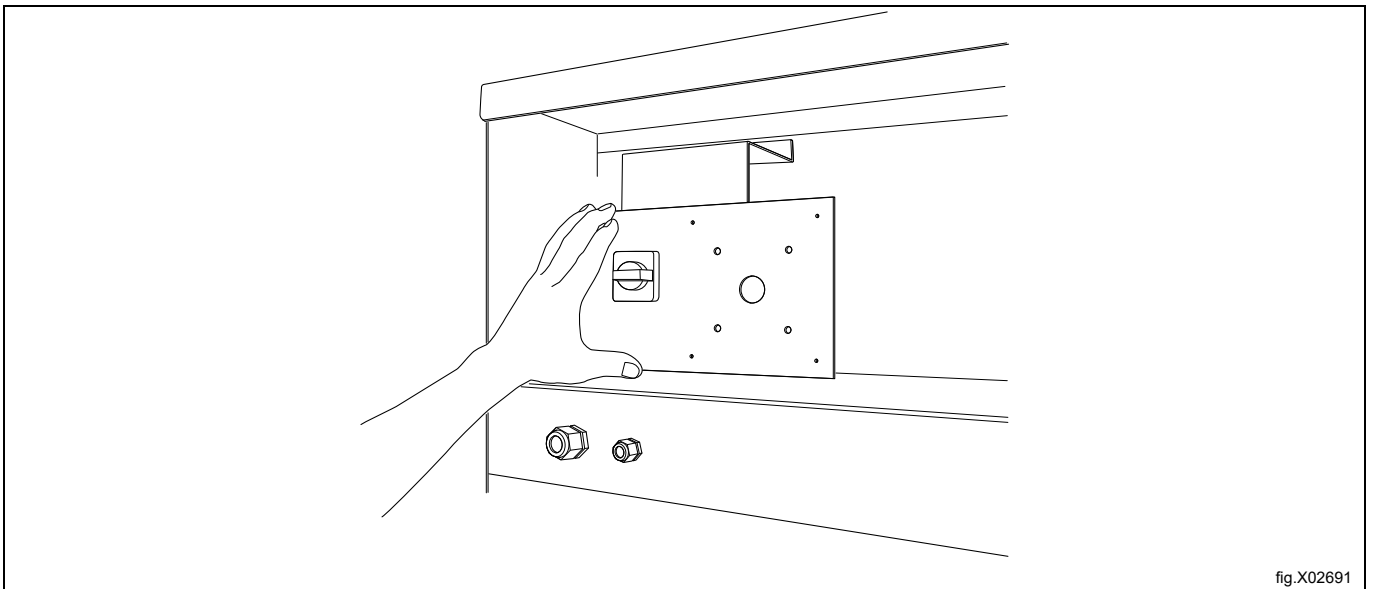

fig.X02691

Mount the back panels (E).

When mounting the component unit back panel (G) its top edge must be tilted under the basic machine's top panel.

E: 2 rear panels: Heating unit (6 screws)

F: Top panel: Basic machine

G. Rear panel: Component unit (6 screws)

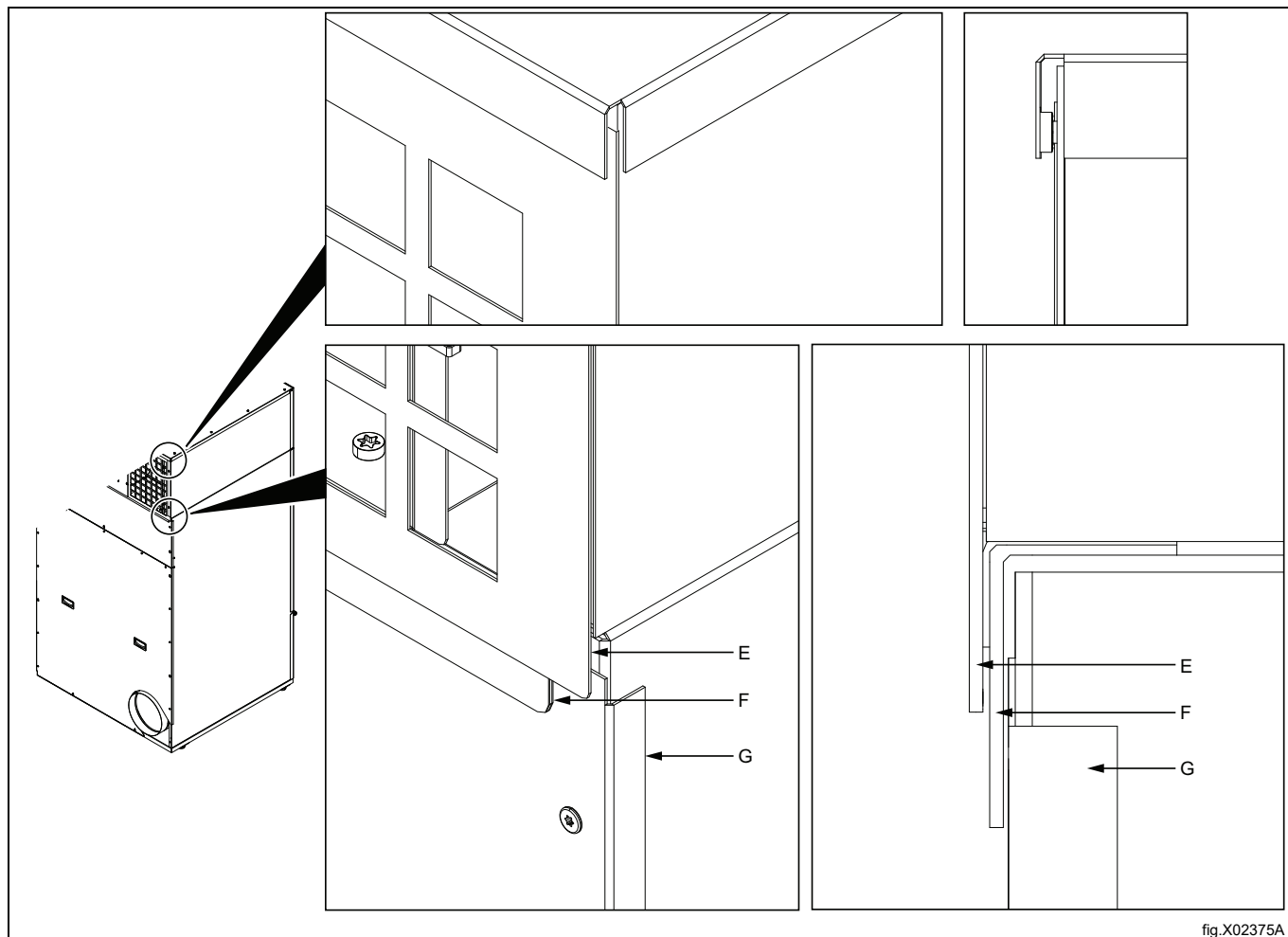

fig.X02375A

Fasten the supply disconnecter panel with handle into the back panel using 6 screws.

Note!

Check that the supply disconnecter can connect and disconnect the power.

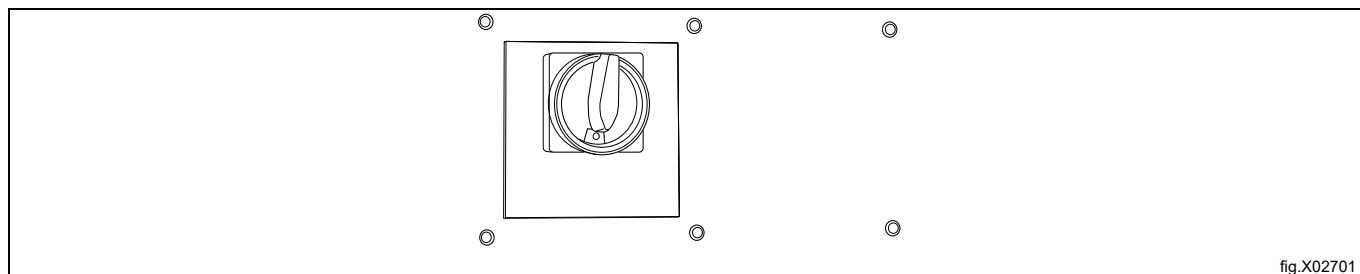
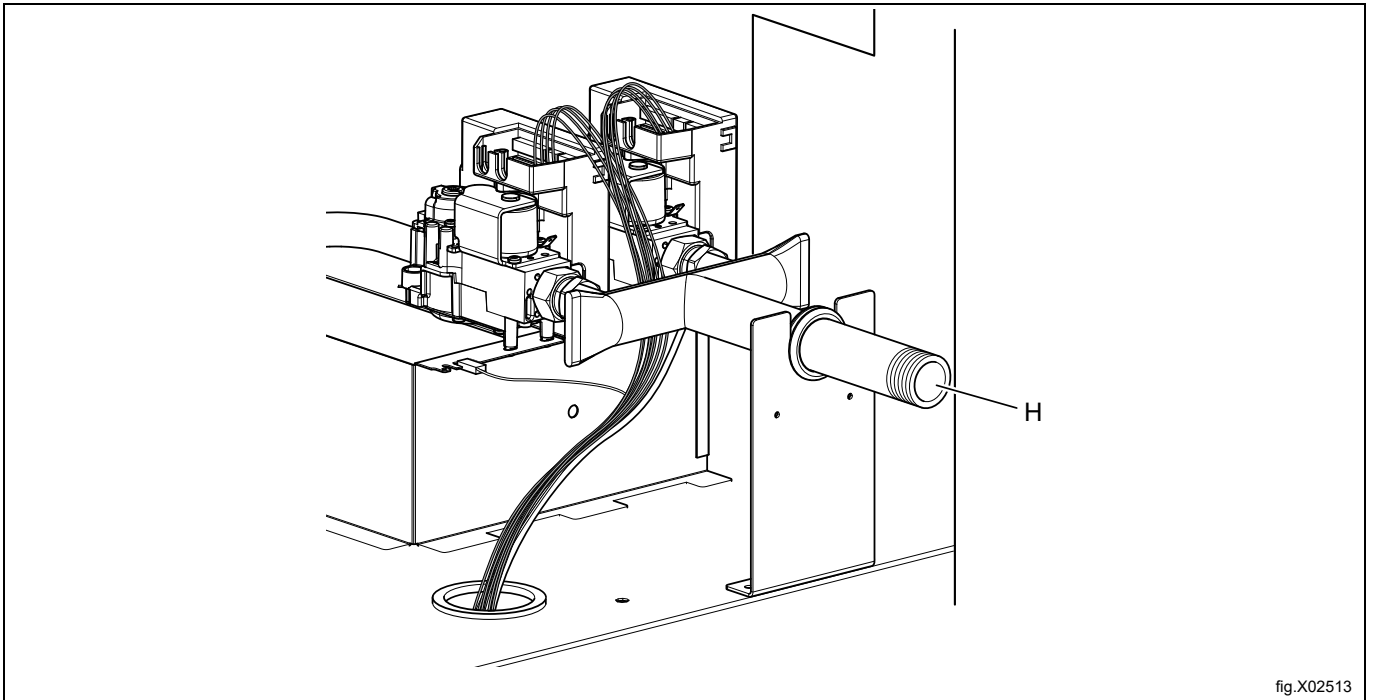

fig.X02701

Connect gas supply to (H).

Mount a manual shut-off valve on the gas pipe upstream from the machine.

For more information, see section "[Gas connection](#)".



5.2 Electric heating unit installation

Check that the electric heating unit is not damaged during transport.

Check that wiring connections and terminals are not bent or defective so there is no risk of short-circuiting.

During transport the contactor console is only fastened loosely, turn it down and fasten it on the side using two screws (A).

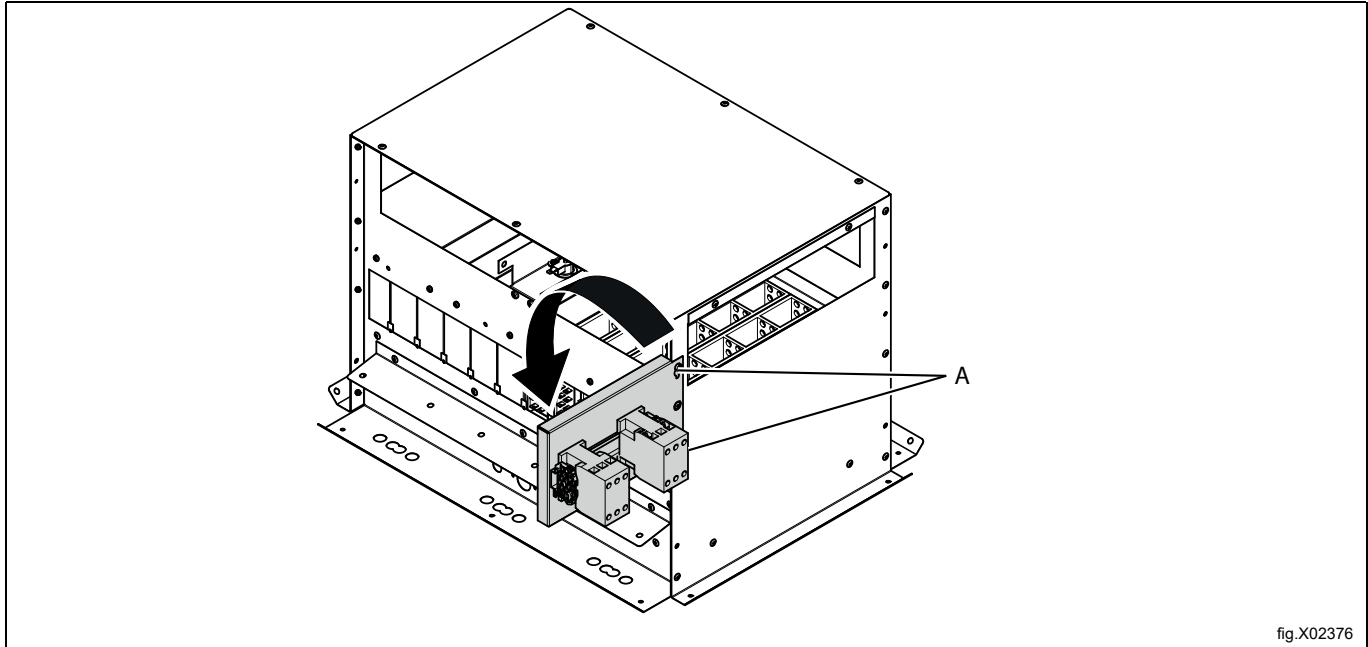

fig.X02376

Put the electric heating unit in position on top of the machine.

The weight of the electric heating unit is approximately 24 kg / 53 lbs.

The electric heating unit shall be lifted according to the illustration. Be careful not to damage any parts.

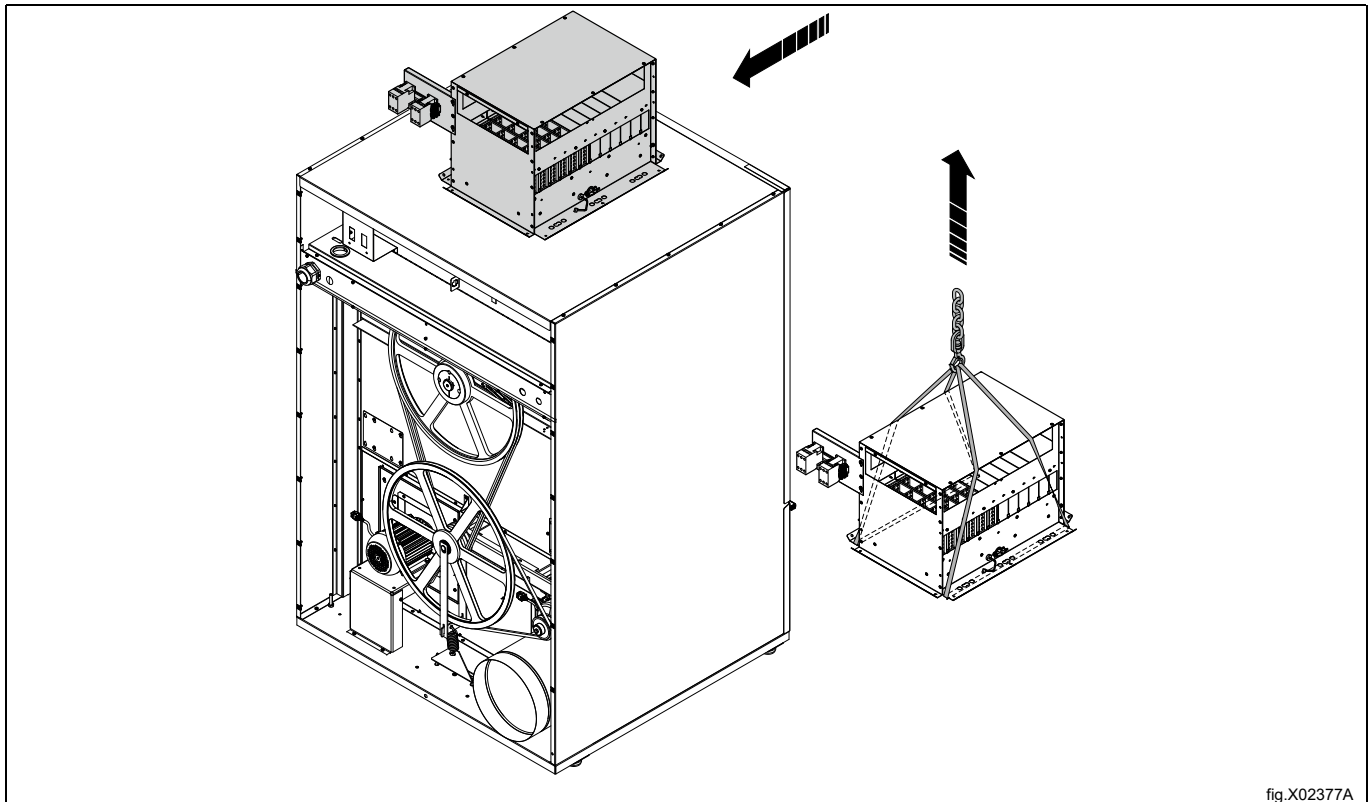

fig.X02377A

Fasten the electric heating unit on the machine.

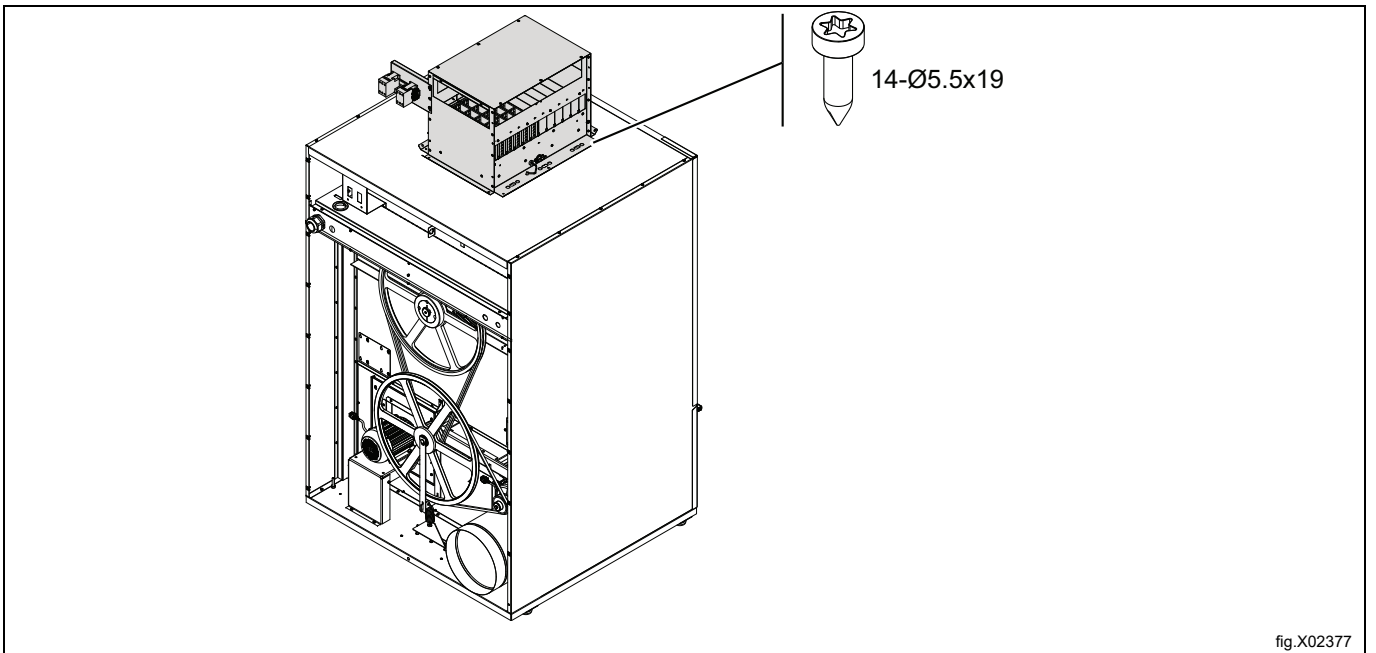

fig.X02377

Mount the brace.

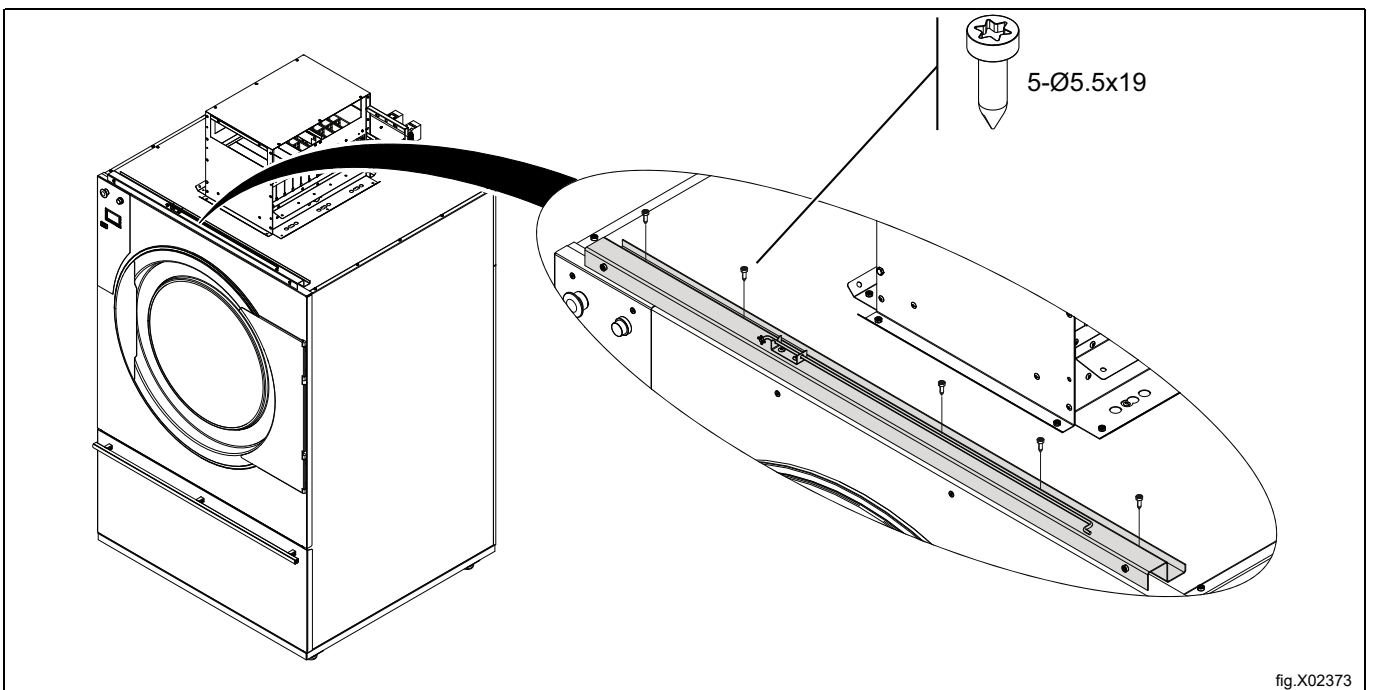

fig.X02373

If the machine has sliding door, go to section [Mounting equipment for sliding door](#), before carrying out the next step.

Mount the side panels using 5 screws on each side as follows:

First fasten the front screw and the back screw but not all the way down. Turn the side panel with the grooves facing downward and mount the side panel in the grooves. Tighten the screws.

Fasten the last 3 screws.

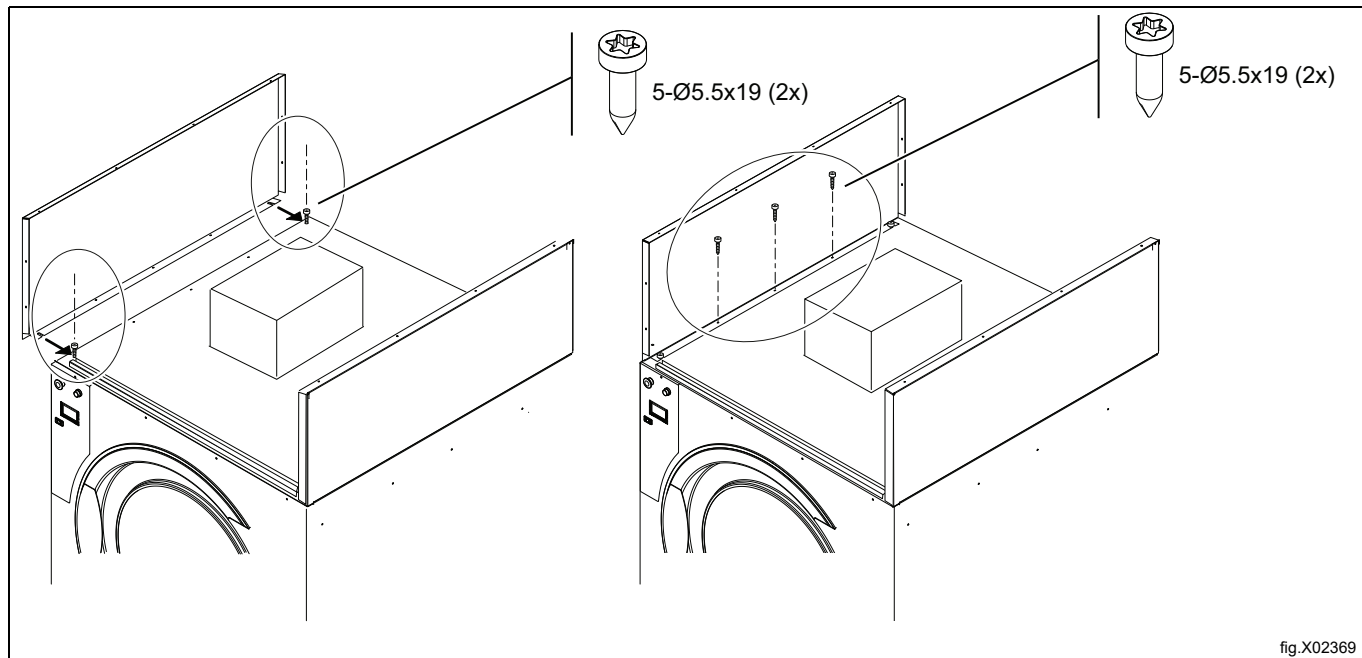

Mount the air maze.

On the side of air maze and panels, pre-mount the screws (1) through the panels to the air maze. Fasten the screws (2).

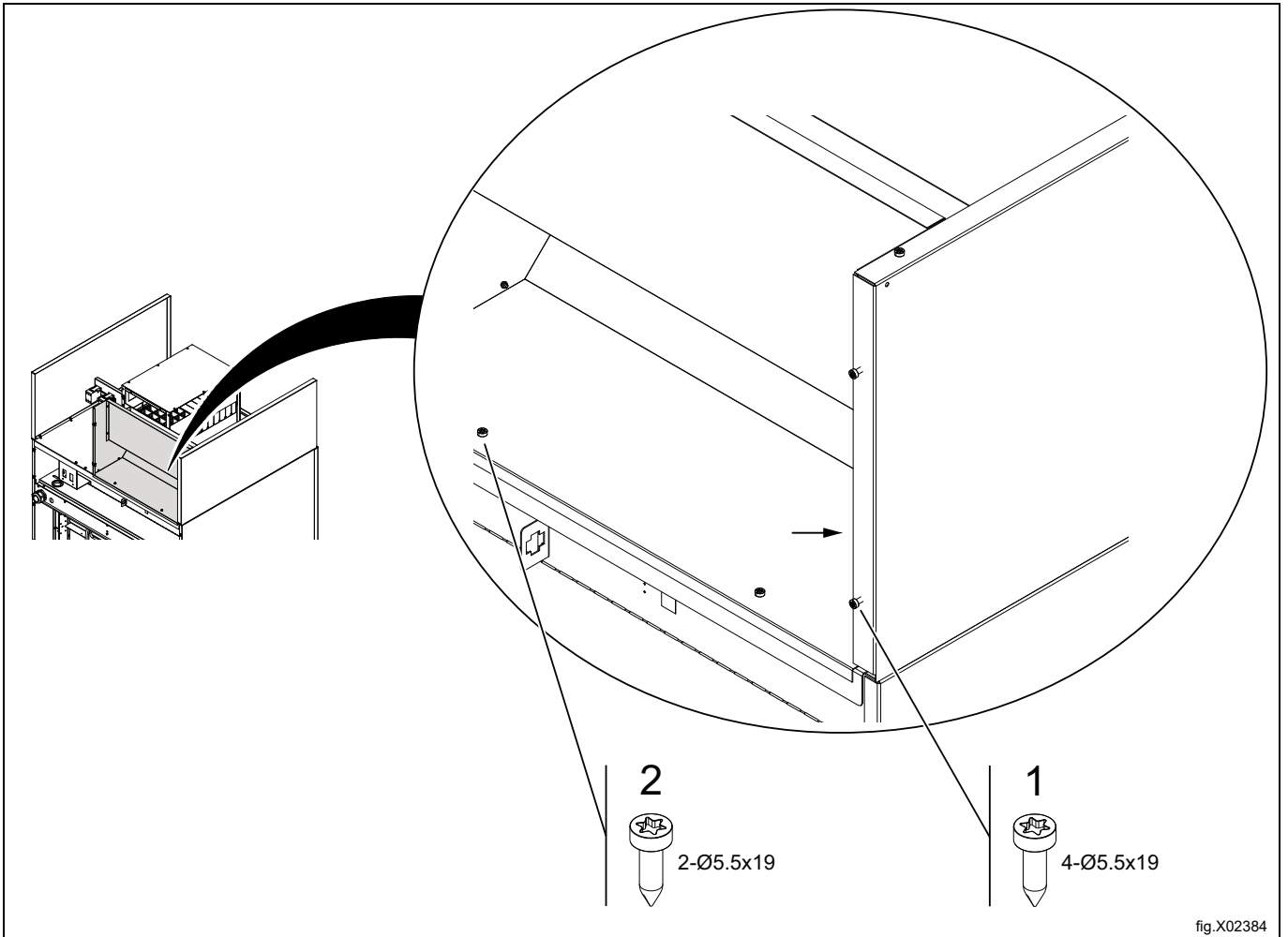

Put the top panel in position but do not fasten it.

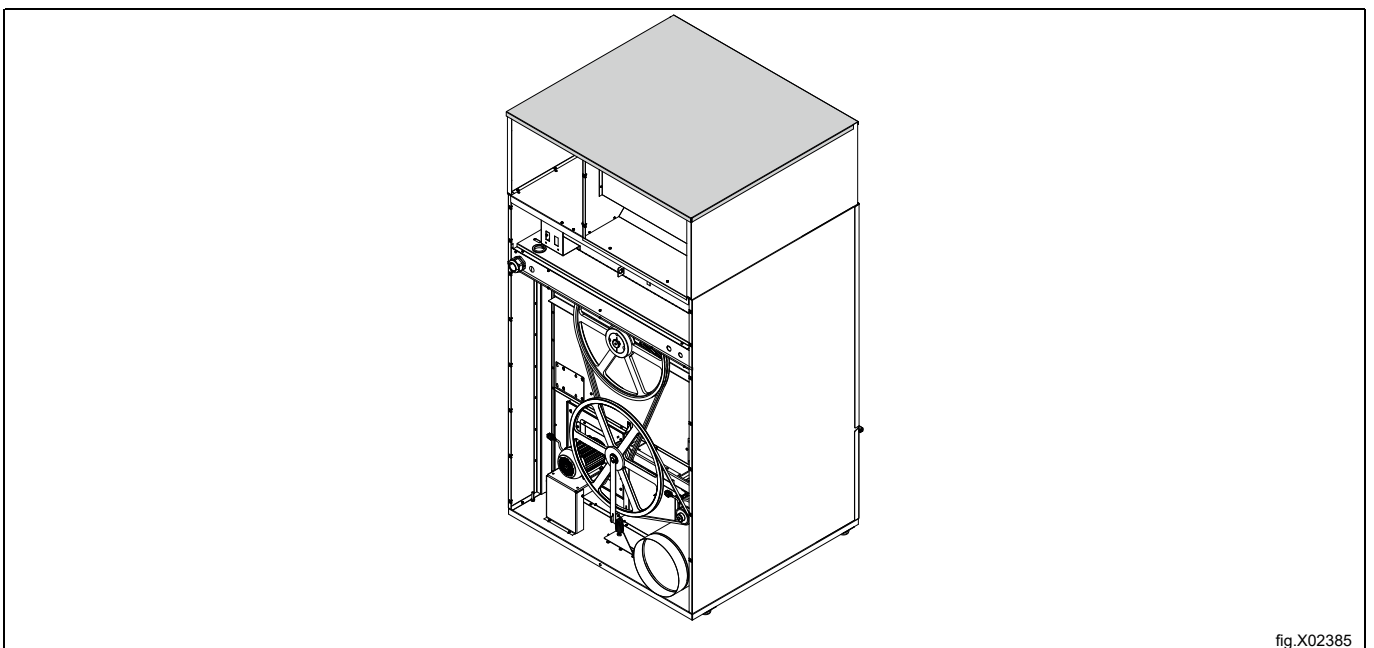

Lead the multiple plug from the electric heating unit down through the cable gland to the component unit and place it in connector marked *B*. Strap the wires according to the figure.

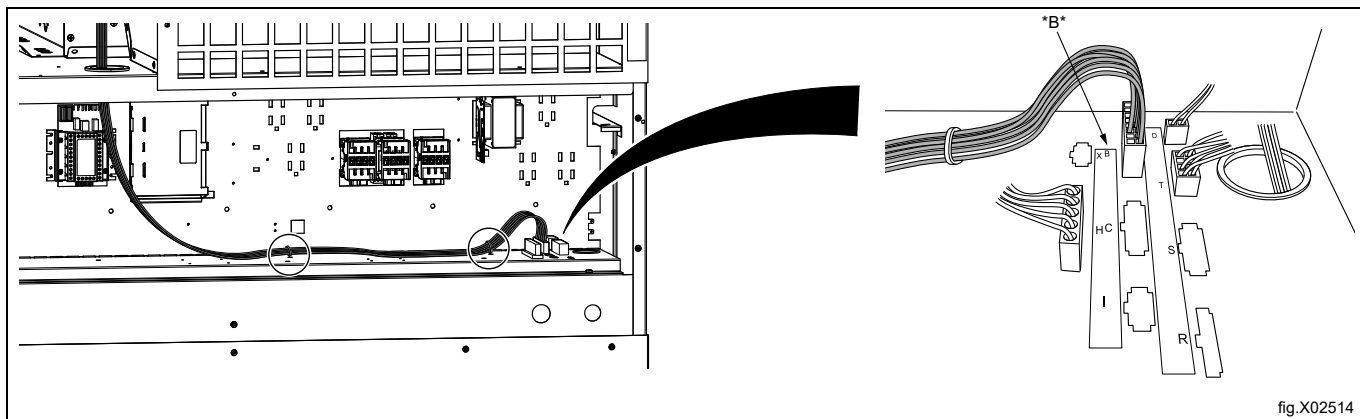

Lead the cables from the connection plinth (E) through the cable gland and connect L1-1 to T1, L2-1 to T2, L3-1 to T3.

Fasten with 4 Nm / 2.9 lbf.ft.

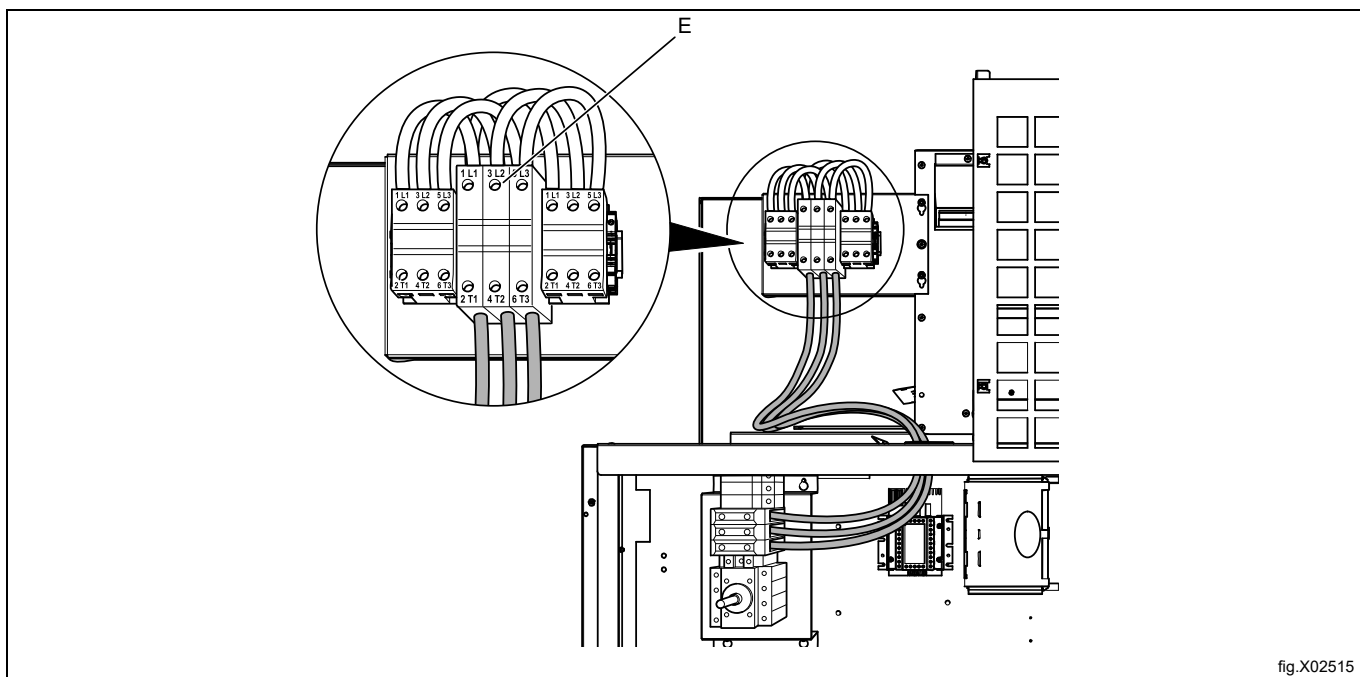

Lead the earthing conductor from the electric heating unit to GND on the connection plinth (F). Fasten with 5 Nm / 3.7 lbf.ft.

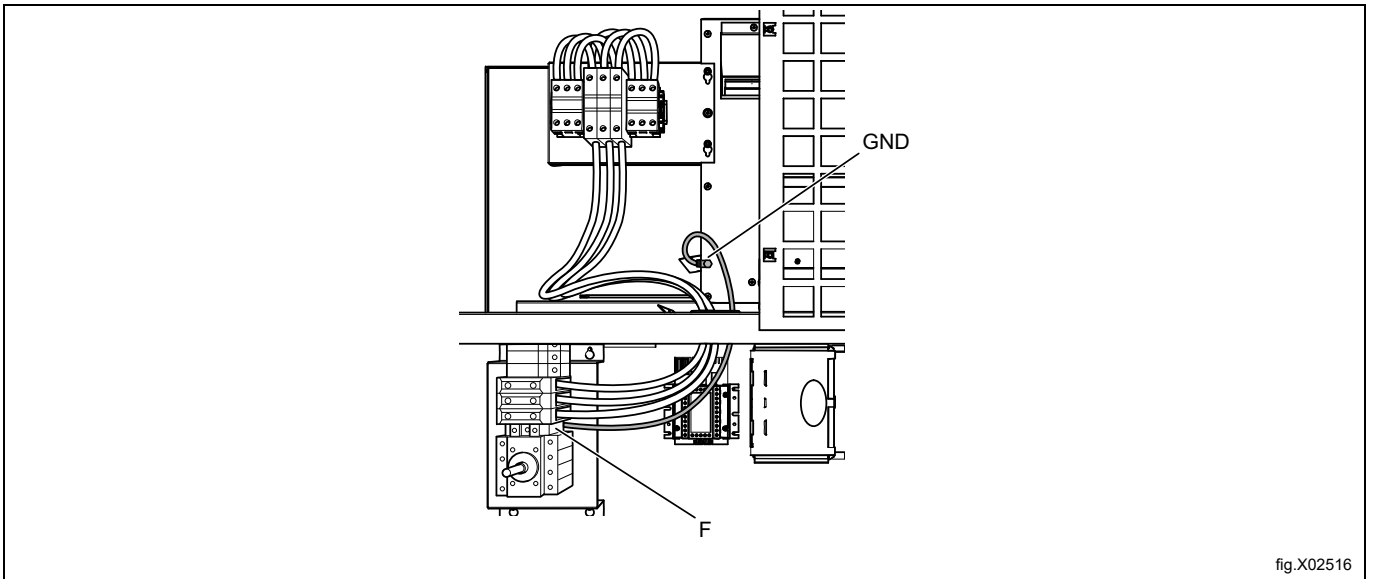

Fasten the panels to the air maze.
Fasten the top panel.

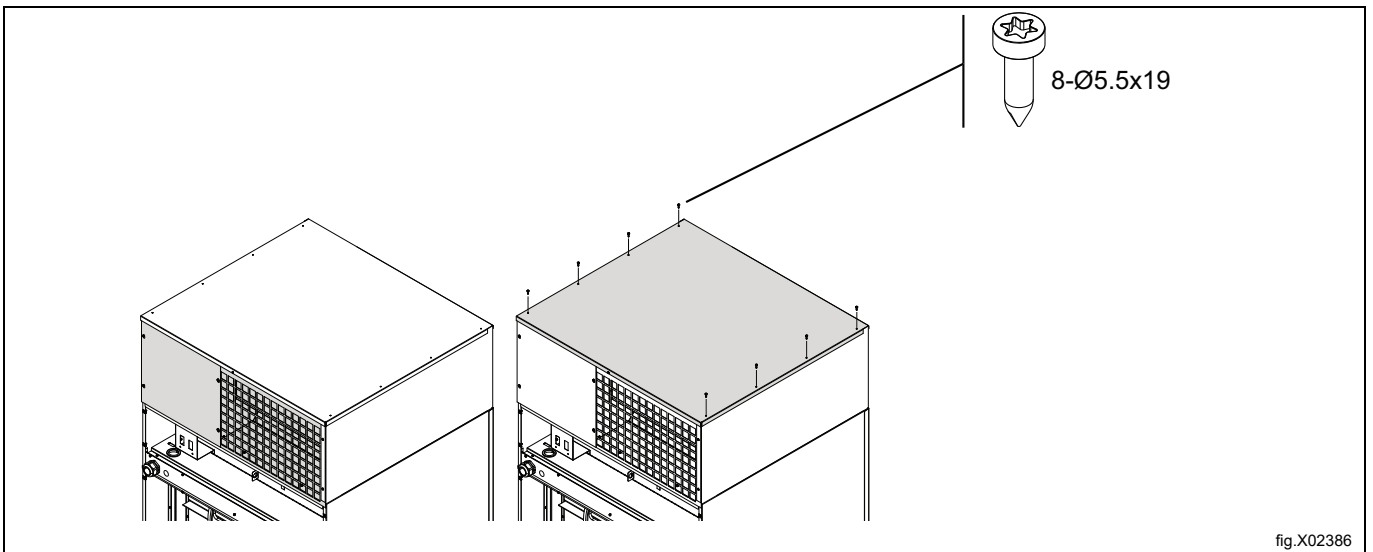

Mount the front panel with 2 screws and locking nuts on the sides. Do not tighten the screws completely. Hold the front panel in open position when mounting the support plate (C). Close the front panel and fasten it with 2 screws on the front. Tighten the 2 screws on the sides.

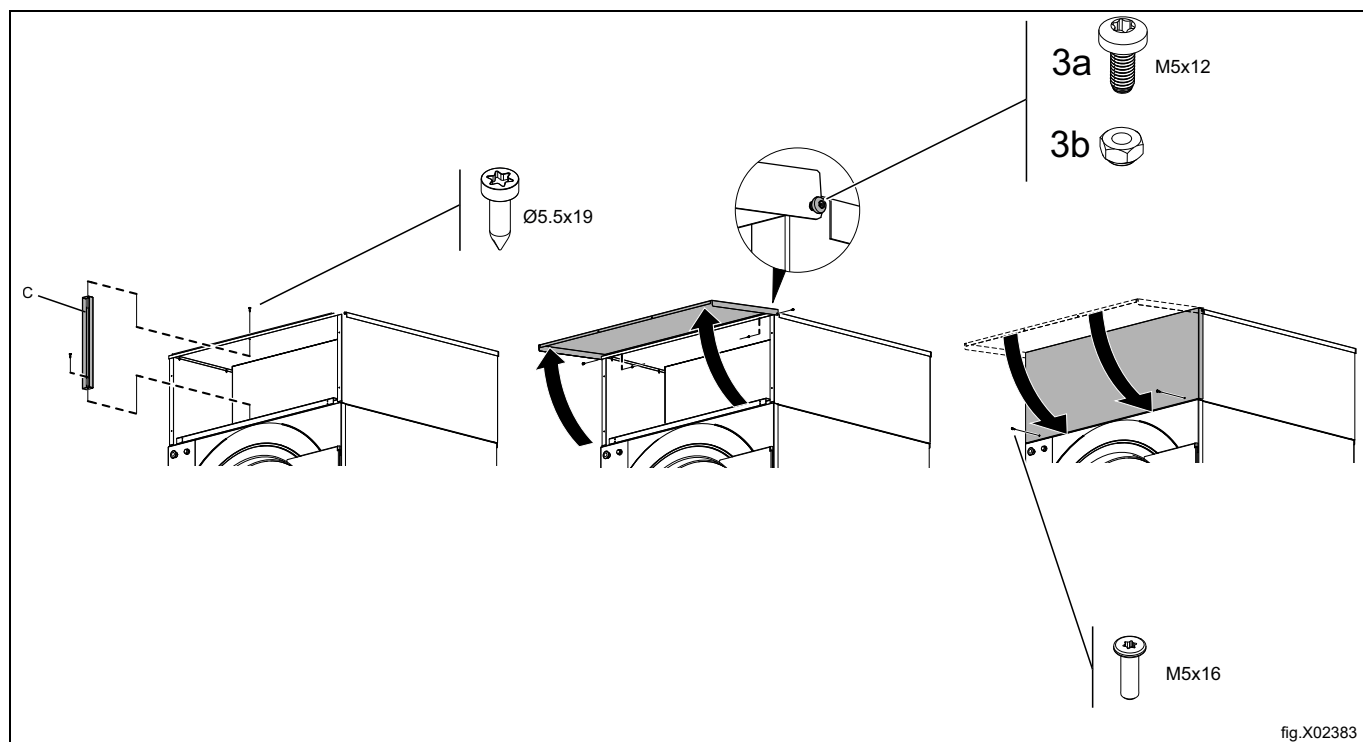

Place the electrical supply disconnecter panel with handle in its place. Mount the supplied M63 cable gland (G) and nut. For more information, see section "[Electrical connection](#)".

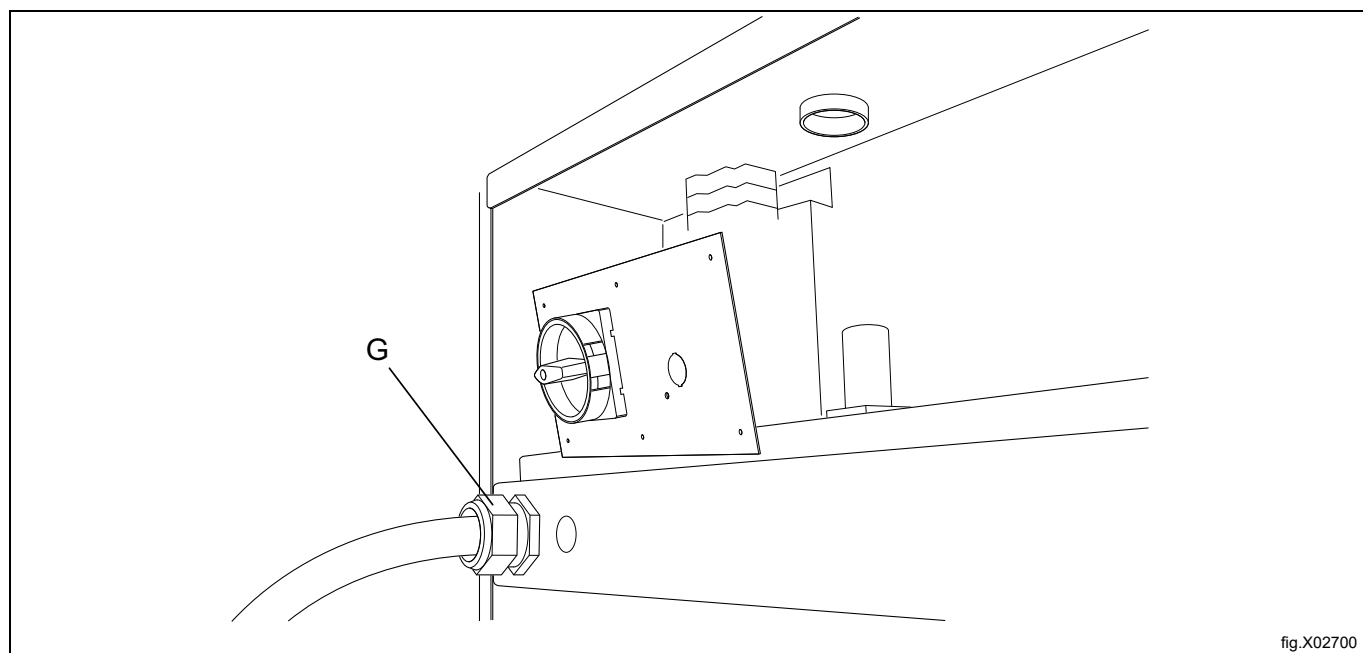

Mount the back panels (E).

When mounting the component unit back panel (G) its top edge must be tilted under the basic machine's top panel.

E: 2 rear panels: Heating unit (7 screws)

F: Top panel: Basic machine

G. Rear panel: Component unit (6 screws)

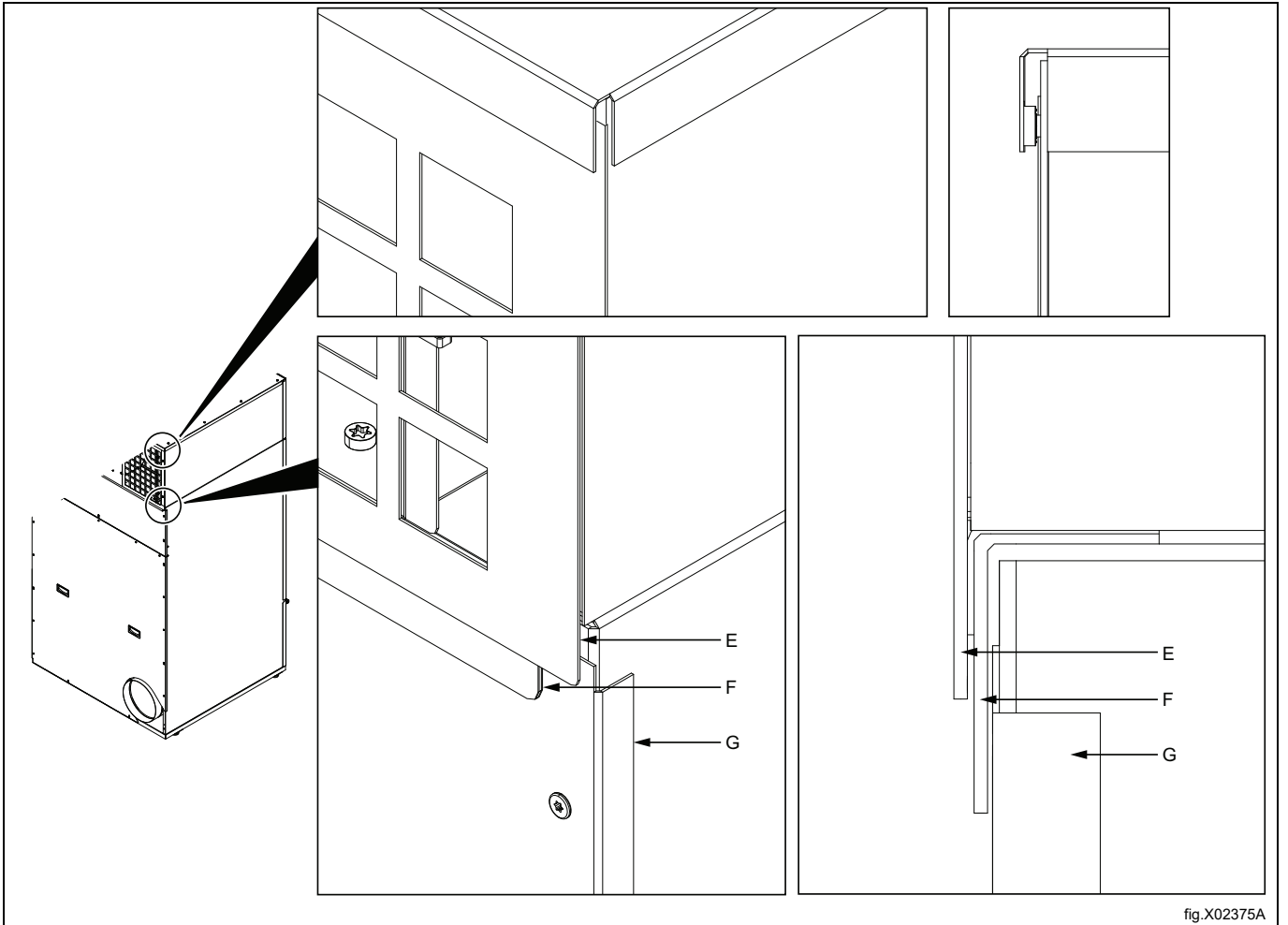

fig.X02375A

Fasten the supply disconnecter into the back panel using 6 screws.

Note!

Check that the supply disconnecter can connect and disconnect the power.

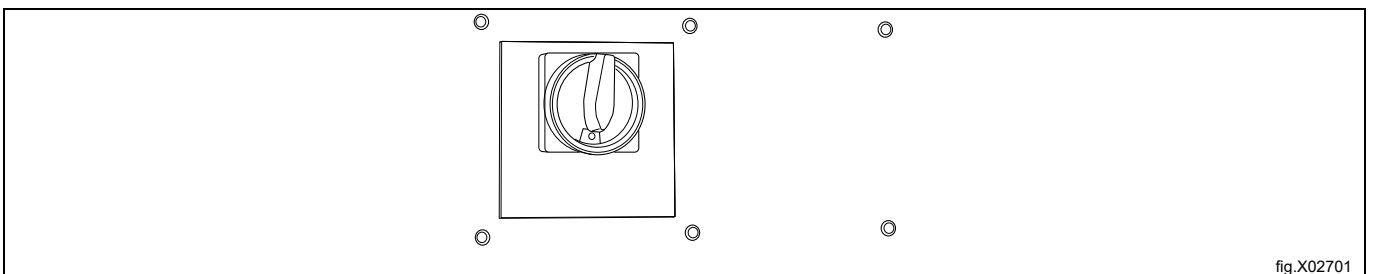

fig.X02701

5.3 Steam heating unit installation

Put the steam calorifier in position on top of the machine.

The weight of the steam calorifier is approximately 40 kg / 88 lbs.

Lift the steam calorifier either with a fork-lift truck or by hand according to the illustration — two persons are required. Be careful not to damage any parts.

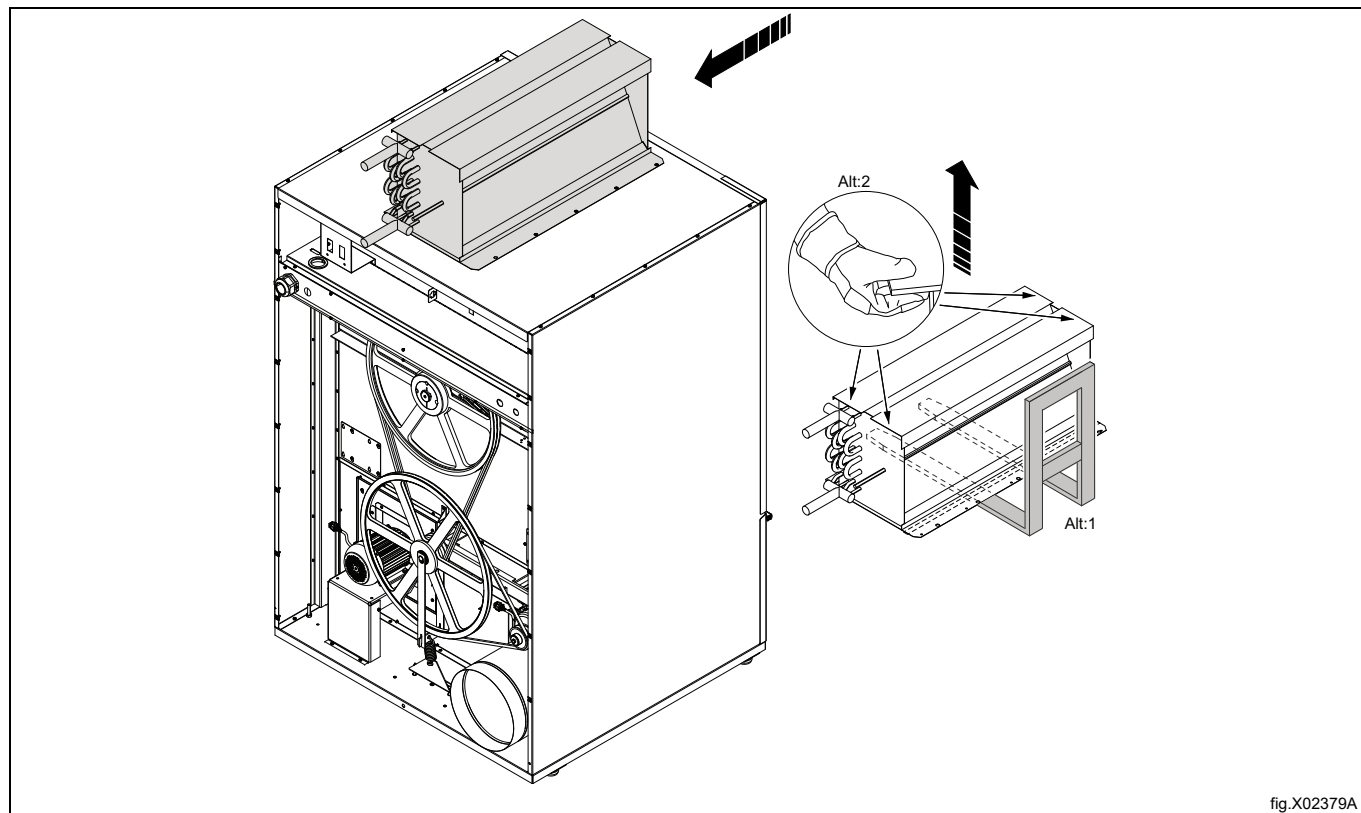

Put the steam calorifier in position on top of the machine.

Fasten the steam calorifier on the machine.

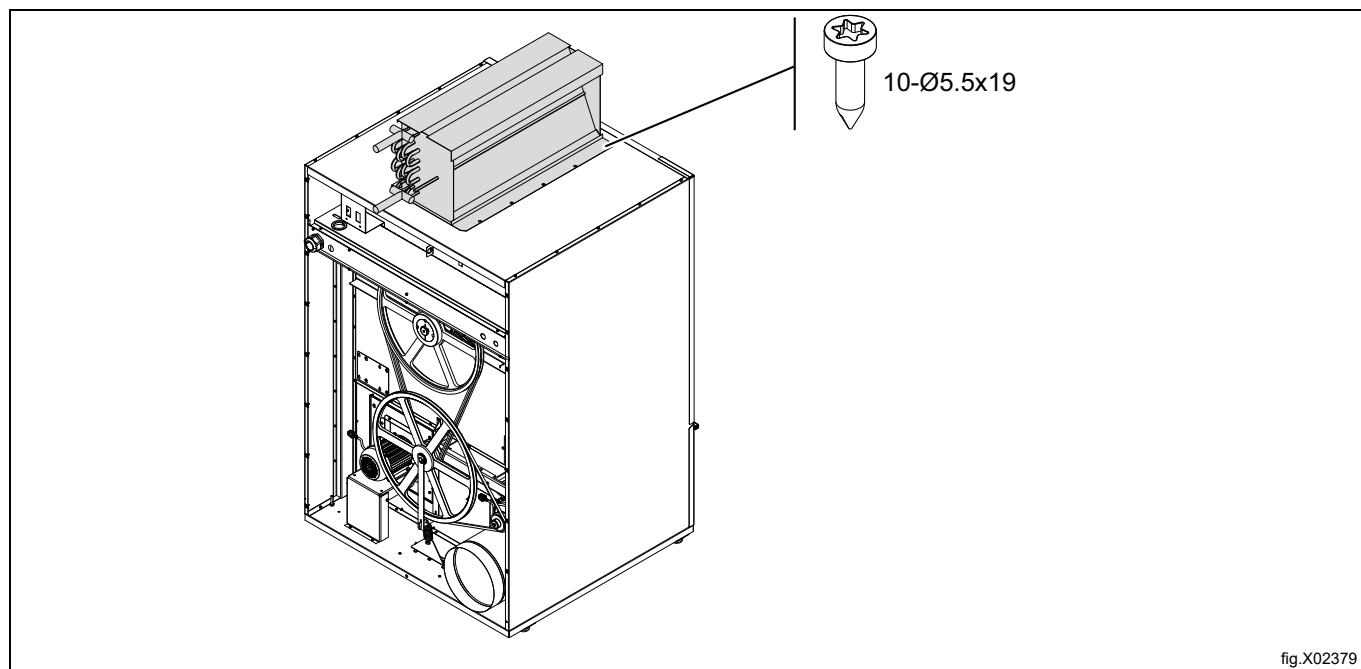

Place the actuator box so that the end of the shaft from the steam calorifier (A) is lead into the hole in the actuator.

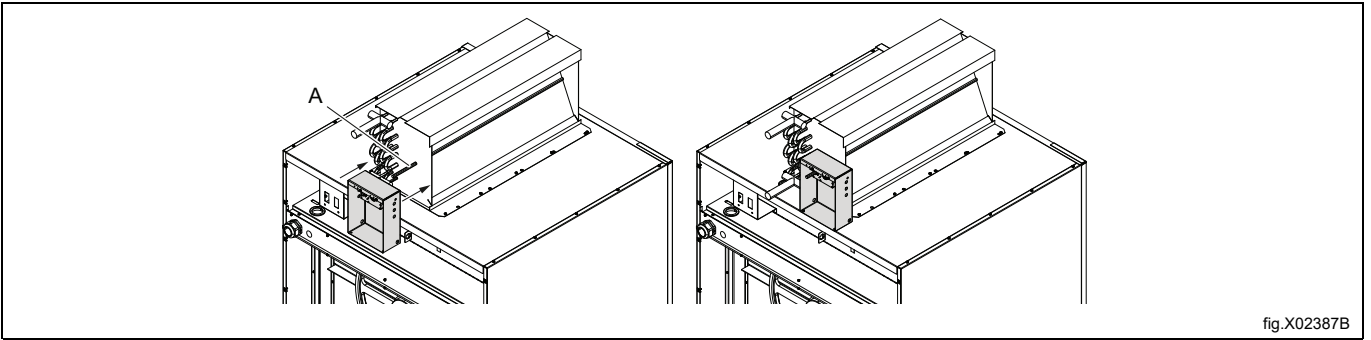

fig.X02387B

Fasten the screw (C).

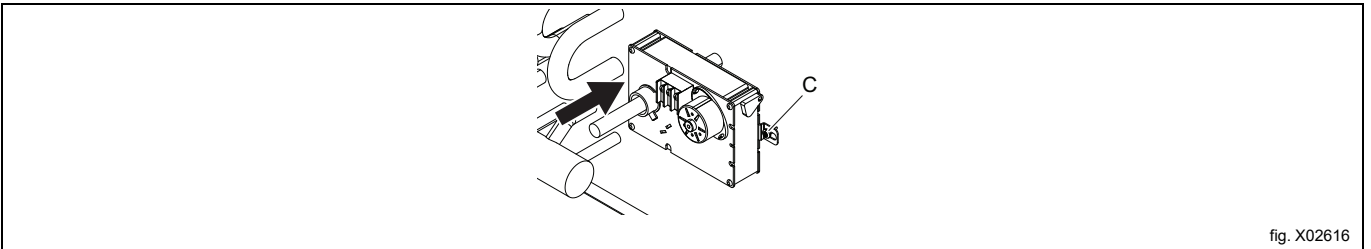

fig. X02616

Release the declutch lever (D) and rotate the hub until it is in CCW position (Y).

Insert the range stop pin (E) in position (supplied with the actuator). (Do not insert the range stop pin (E) until the hub position shown has been reached). The range stop pin is clipped into its final position only after the pin passes through both actuator plates. The range stop pin should snap into position and not be removable manually.

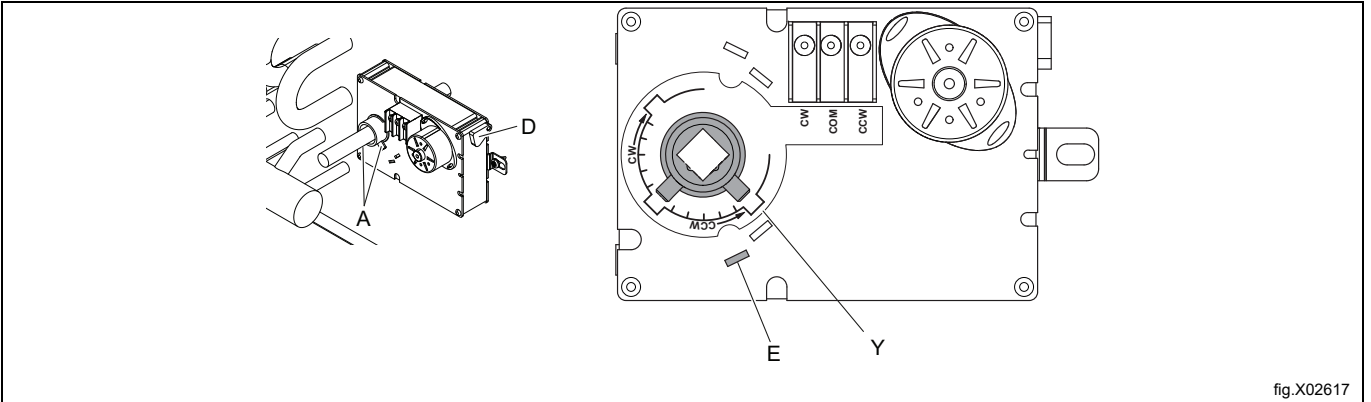

fig.X02617

Keep the damper in open position. Ensure that the damper opens and closes smoothly and that the damper does not scratch the sides of the heating unit (xx). Adjust the position of the damper forward or backward if necessary.

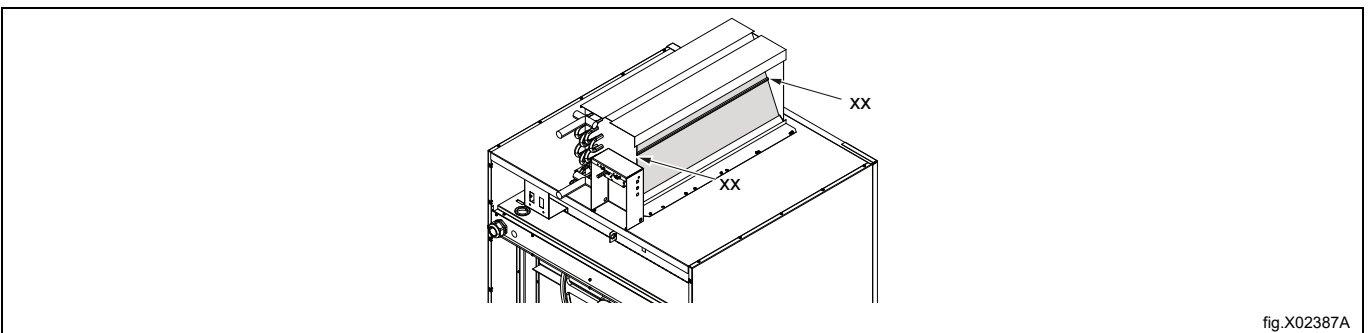

fig.X02387A

Note!

When tightening the end of the shaft the damper must be open (B).

Using two tailstock screws tighten the end of the shaft (D) to 5 Nm with a 1/8" Allen key **Note! It is a 1/8" key, not a mm key.**

It is possible to adjust the damper opening by turning the manual declutch lever (E) according to the illustration:

C = damper closed,

B = damper open.

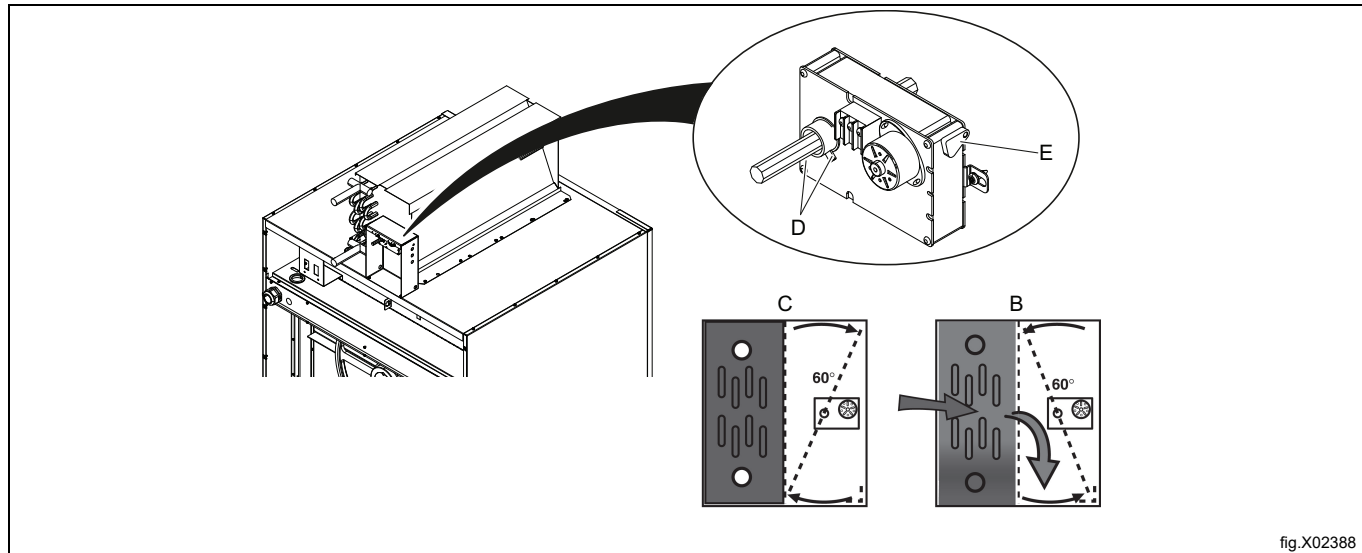

fig.X02388

Mount the wires in screw terminals (B).

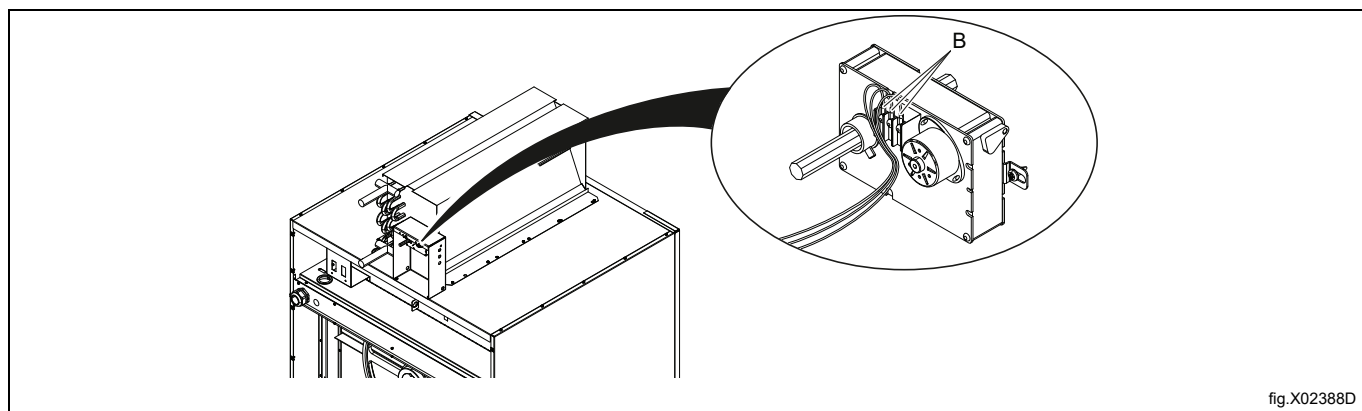

fig.X02388D

Lead the multiple plug from the actuator box down through the cable gland to the component unit and place it in connector marked *B*. Strap the wires according to the figure.

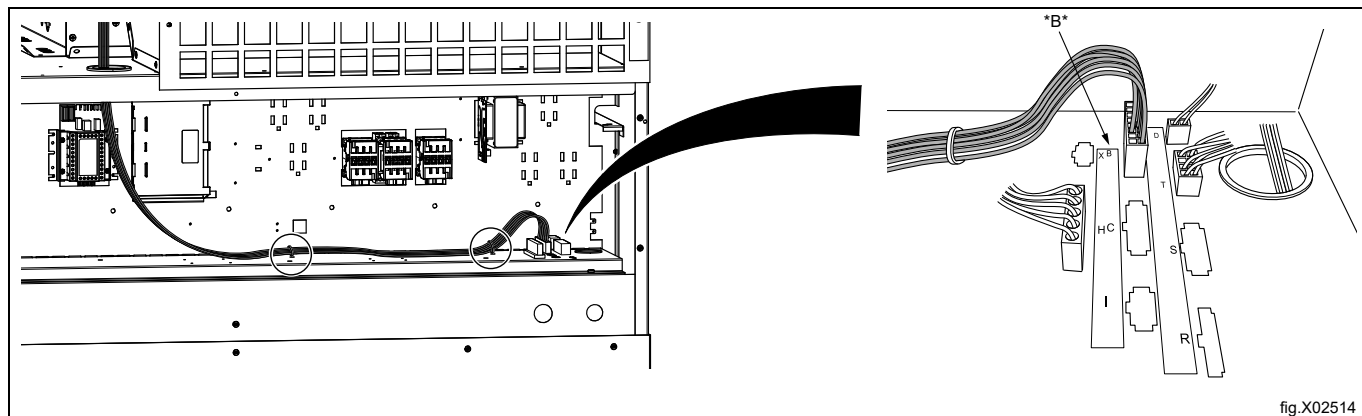

fig.X02514

Place the supply disconnecter panel with handle in its place.
 For more information, see section "[Electrical connection](#)".

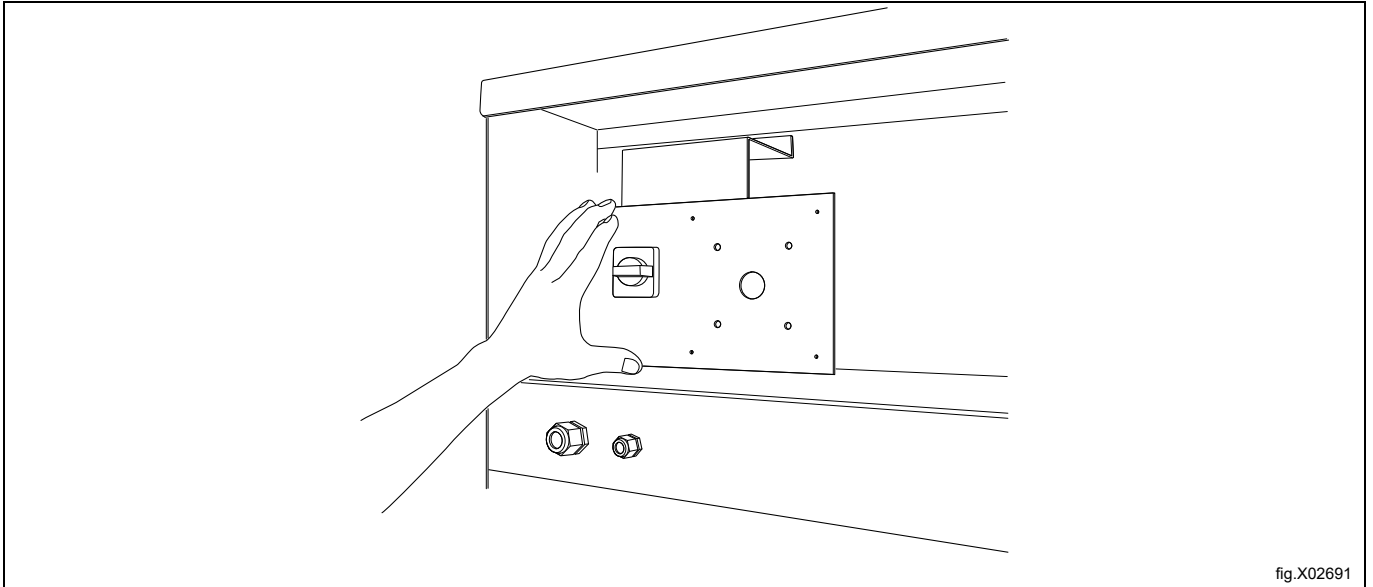

fig.X02691

Mount the two back panels. When mounting the component unit back panel its top edge must be tilted under the basic machine's top panel.

It is possible to mount the wires from the installation before mounting the back panel.

Fasten the supply disconnecter panel with handle into the back panel using 6 screws.

Note!

Check that the supply disconnecter can connect and disconnect the power.

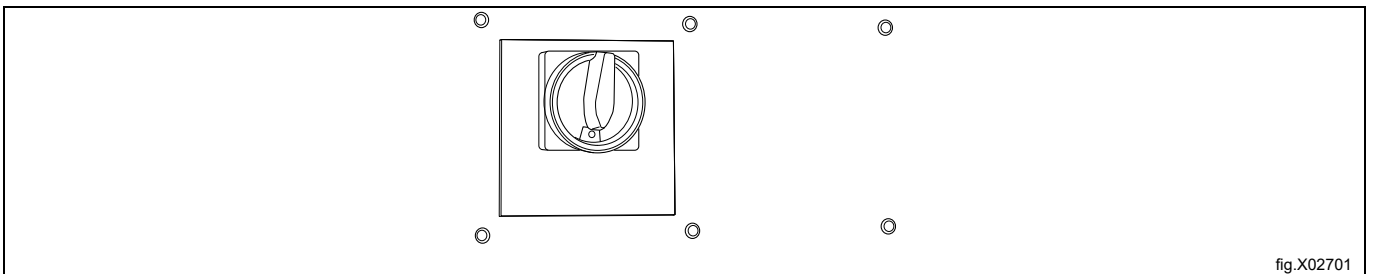
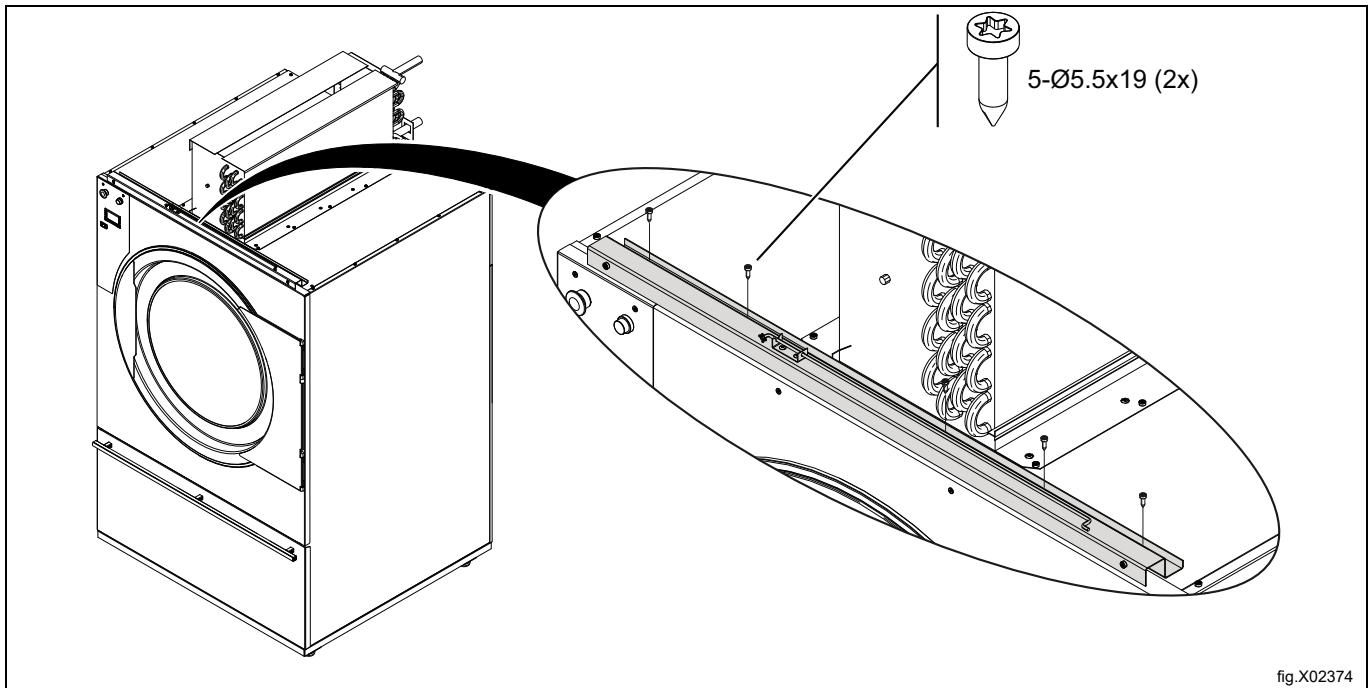

fig.X02701

Mount the brace.



If the machine has sliding door, go to section [Mounting equipment for sliding door](#), before carrying out the next step.

Mount the side panels using 5 screws on each side as follows:

First fasten the front screw and the back screw but not all the way down. Turn the side panel with the grooves facing downward and mount the side panel in the grooves. Tighten the screws.

Fasten the last 3 screws.

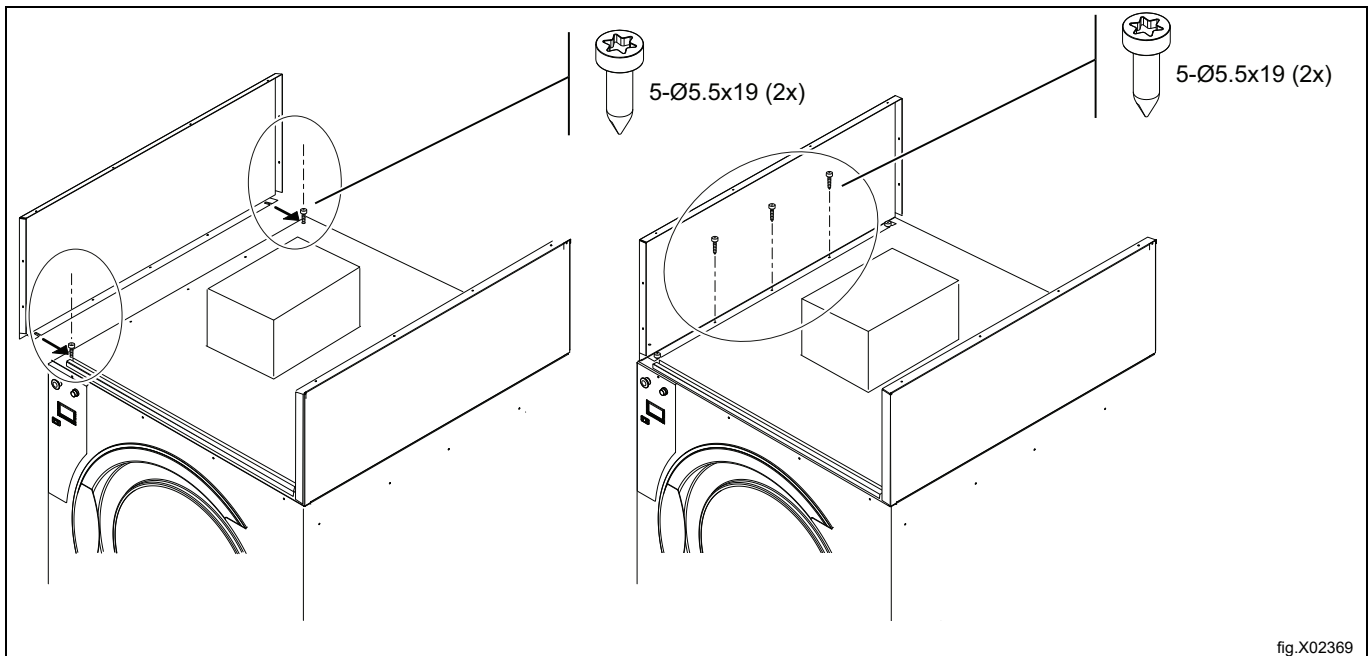

Mount the air maze.

On the side of air maze and panels, pre-mount the screws (1) through the panels to the air maze. Fasten the screws (2).

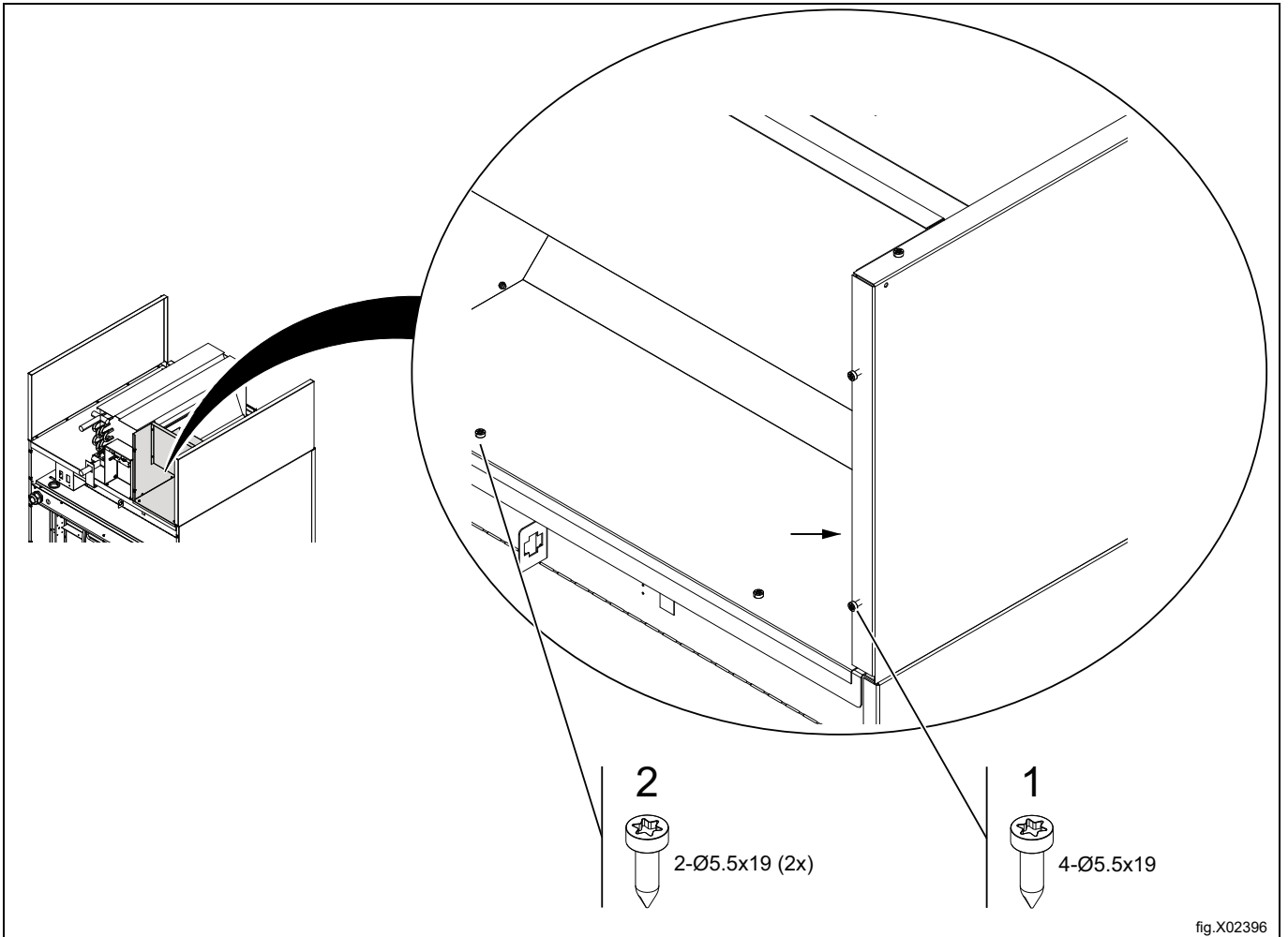

Put the top panel in position but do not fasten it.

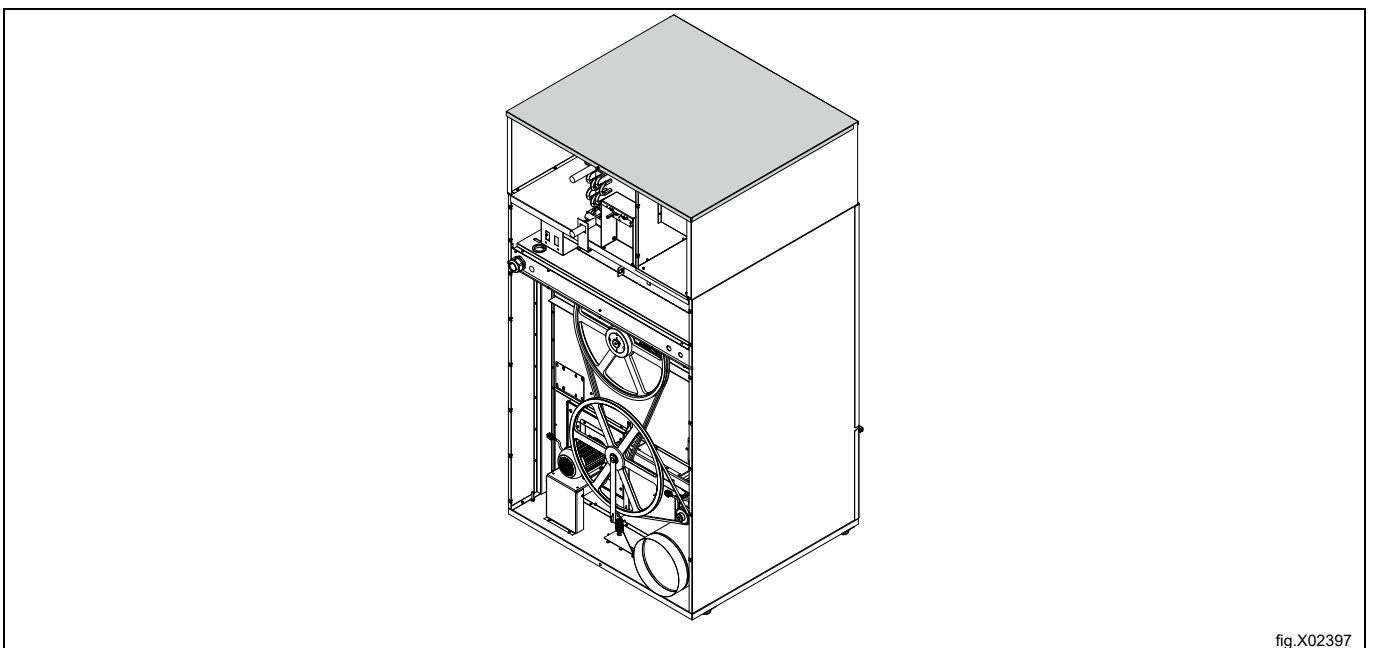

Fasten the panels to the air maze.

Fasten the top panel.

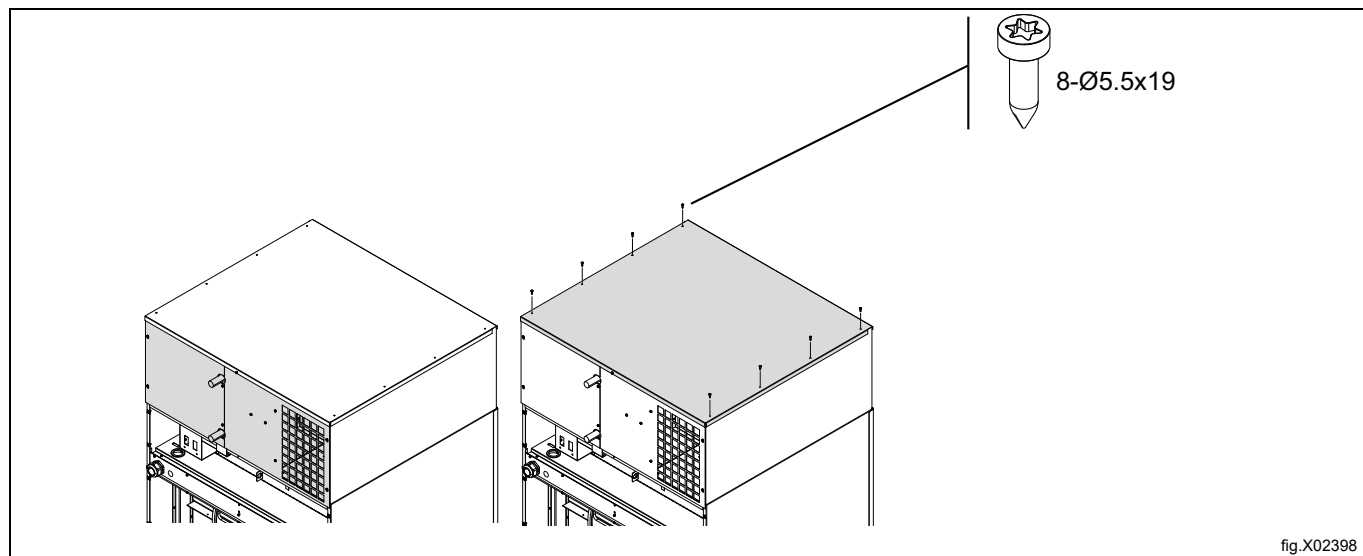

Mount the front panel with 2 screws and locking nuts on the sides. Do not tighten the screws completely.

Hold the front panel in open position when mounting the support plate (C).

Close the front panel and fasten it with 2 screws on the front.

Tighten the 2 screws on the sides.

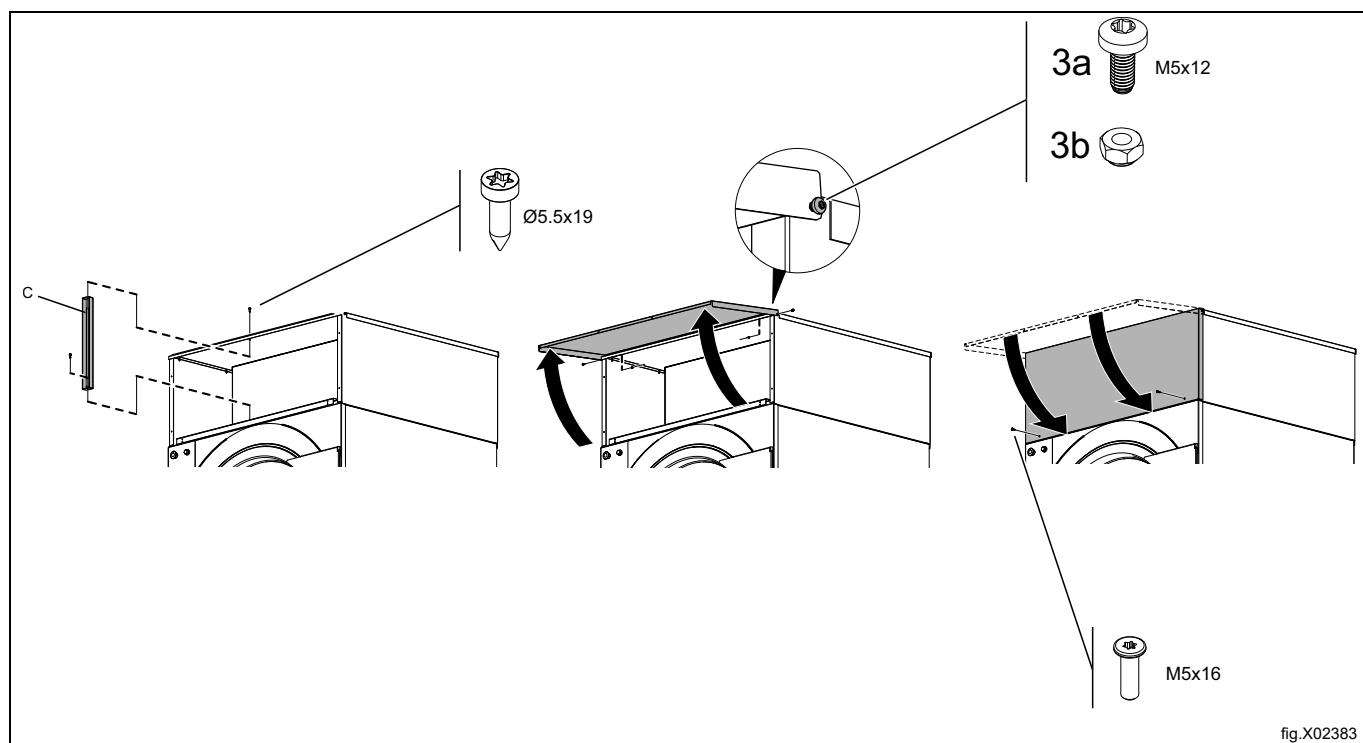

Mount the back panels of the heating unit (E).

When mounting the component unit back panel (G) its top edge must be tilted under the basic machine's top panel.

E: 2 rear panels: Heating unit (6 screws)

F: Top panel: Basic machine

G. Rear panel: Component unit (6 screws)

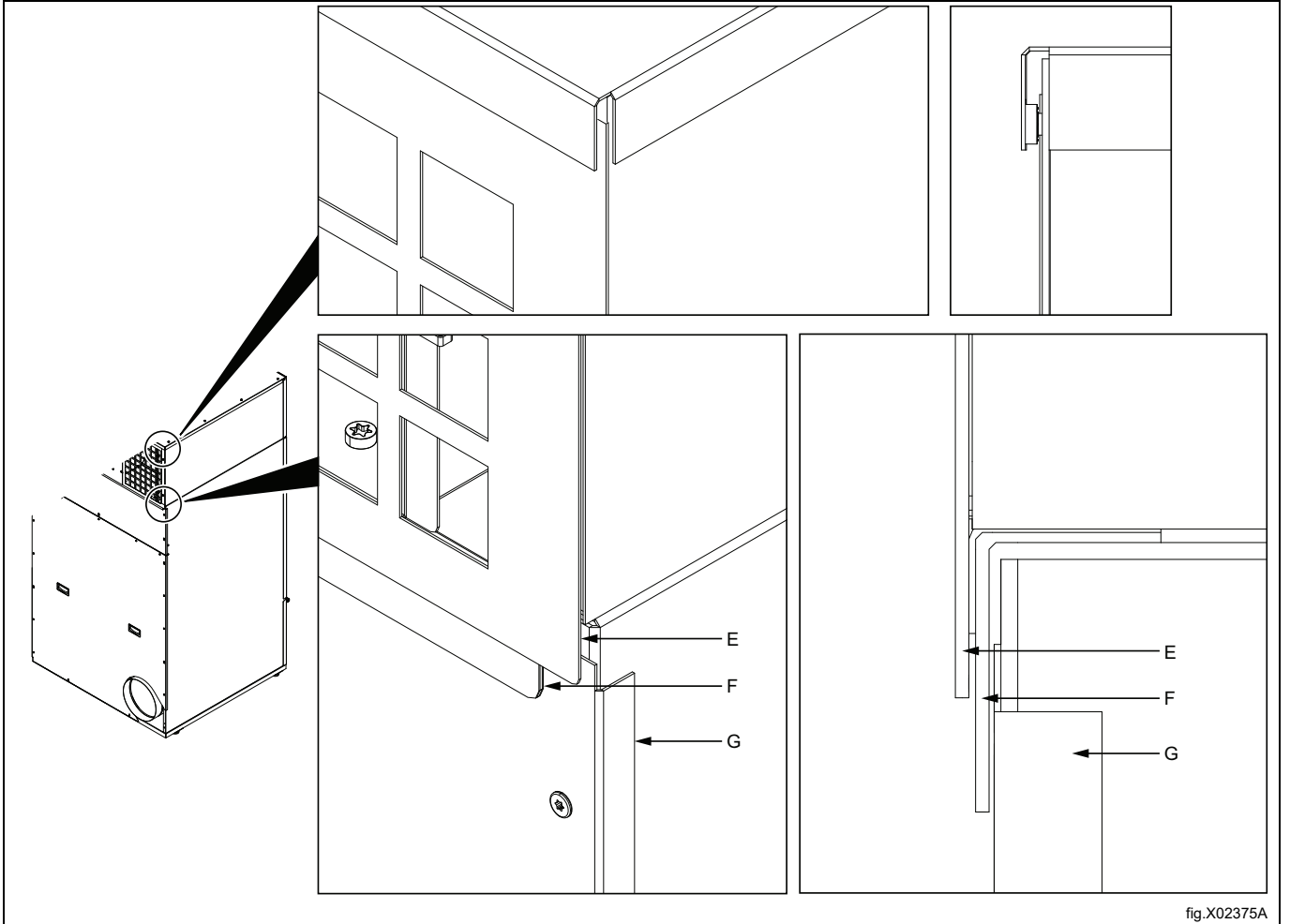

fig.X02375A

Connect the steam.

For more information, please refer to the section "Steam connection".

1 = Inlet

2 = Return (condense)

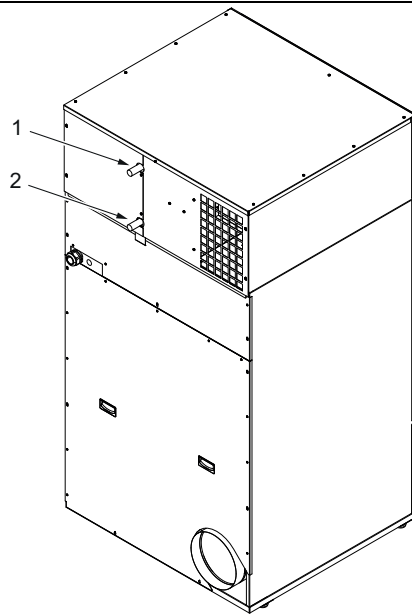
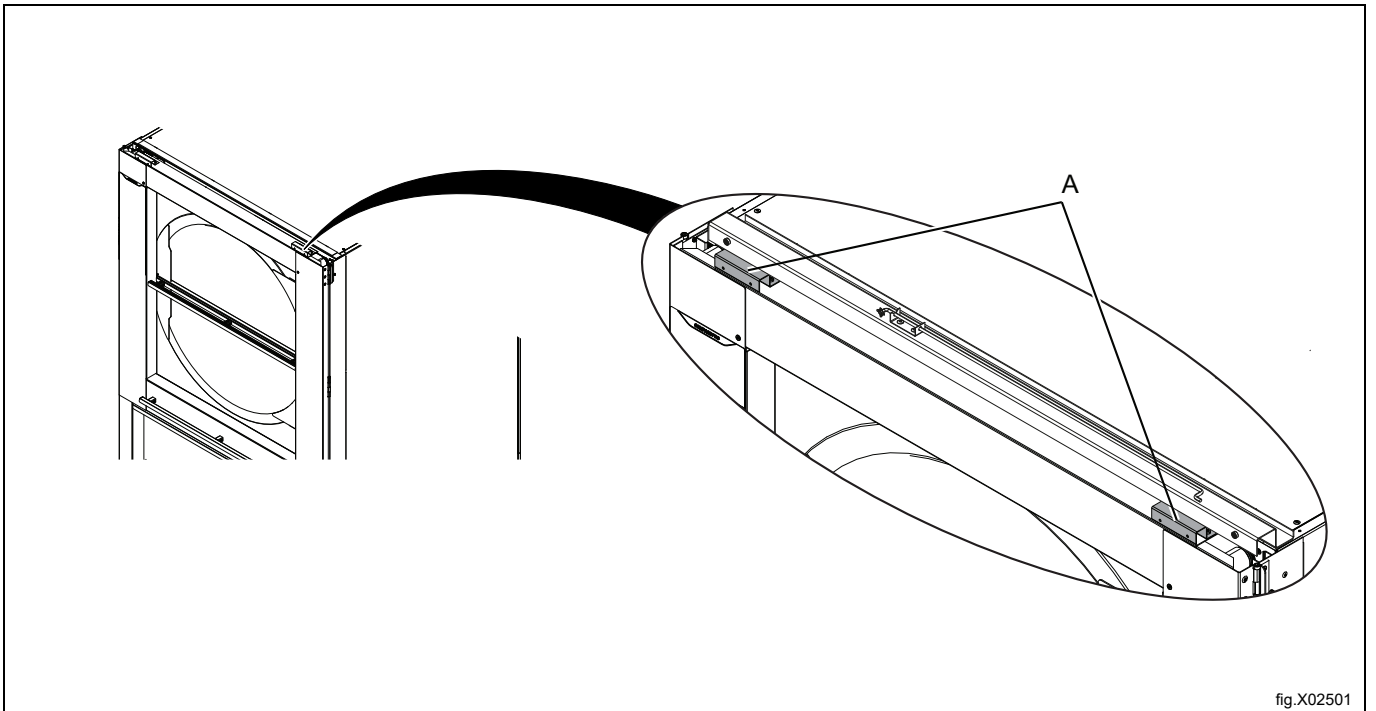

fig.X02399

6 Mounting equipment for sliding door

Mount the 2 angle braces (A) using 2 screws in each one.



Mount the side panels (B) from above and push them down as far as they will go.

Mount screws (C) in order to lock the side panels (2 screws on each side).

Mount screws (D) to lock (B) with the upper side panel (after the side panels have been mounted).

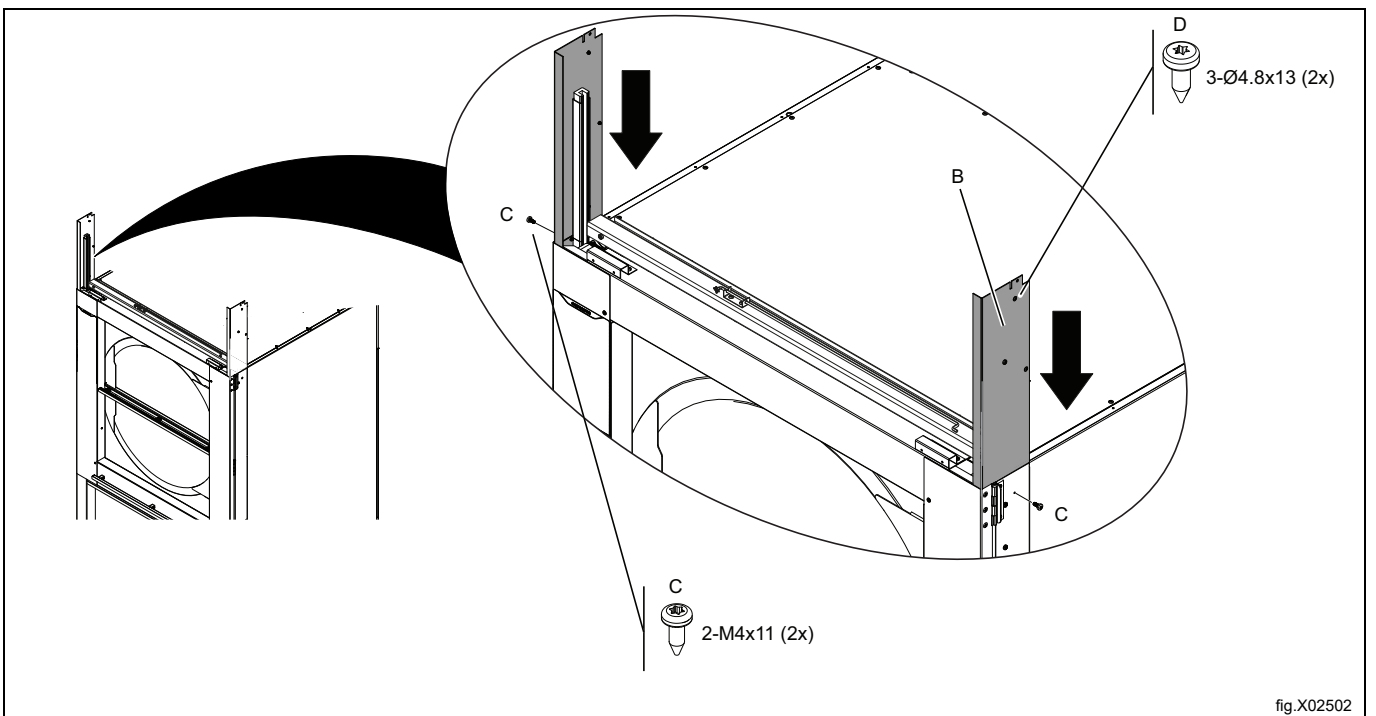

Mount the side panels and the remaining parts as described in [Installation of heating unit](#).

Check that the doors slide open easily.

Note!

It is important that the mounting is carried out carefully, vertical and level as this influences the movement of the sliding door.

7 Installation of tilting unit

7.1 Set up

7.1.1 Flexible piping connection, gas heated machines

Due to the tilting function gas pipe (A) must end 300 mm before the machine and the last piece of it must be flexible eg. an approved 600 mm gas hose.

7.1.2 Flexible piping connection, steam heated machines

Due to the tilting function the steam hoses must have an excessive length of 300 mm.

7.1.3 Outlet duct, all heating types

Due to the tilting function the outlet duct (B) must have a flexible hose 200 mm before the machine.

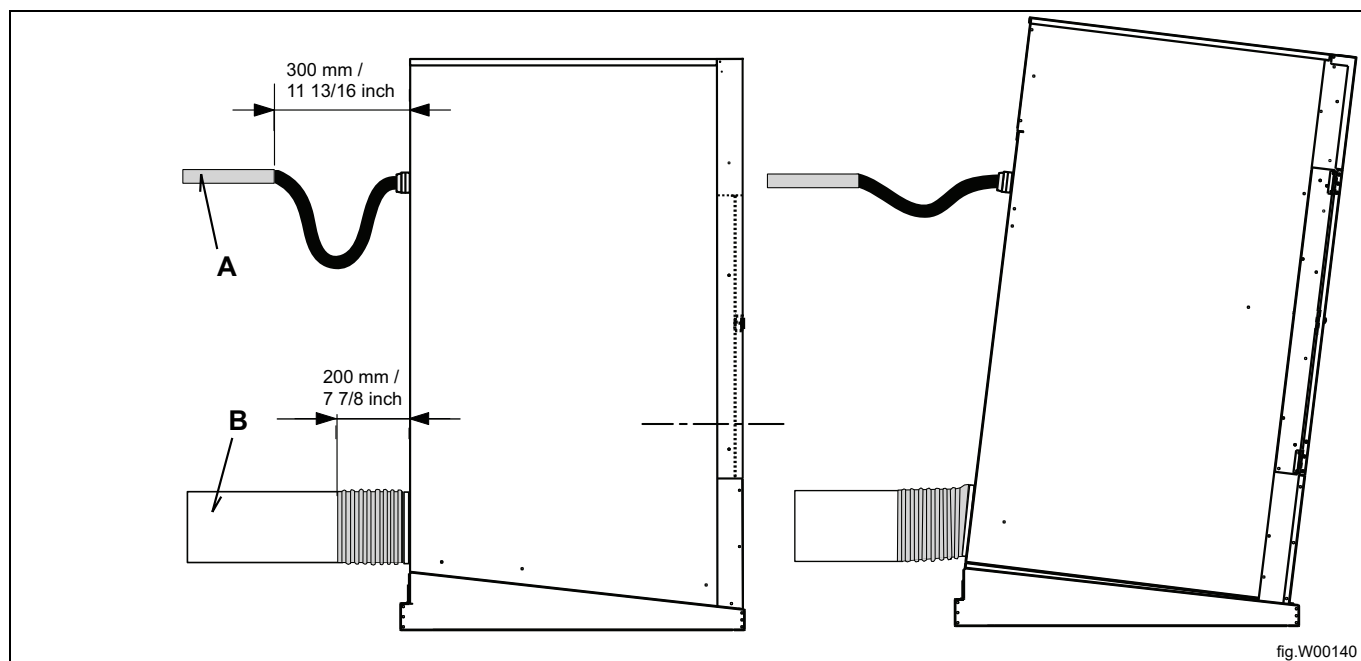

7.2 Contents of the tilting unit kit

Description	Art. No.	Pcs	ID in this instruction	Comment
Left mounting base	487242771	1	A	With 2 foundation feet (F)
Right mounting base	487242770	1	A	With 2 foundation feet (F)
Mounting base front	487243655	1	B	
Mounting base back piece	487243755	1	C	
Adjusting plate 1 mm	487242725	5	D	
Adjusting plate 2 mm	487242726	5	D	
Adjusting plate 3 mm	487242727	5	D	
Expansion bolt	471830102	8	R	M8 x 120 for fastening in the floor
Bolt	487242778	2	E	M20 x 30
Washer	487242777	2	E	M20
Console	487242605	2	E	For front foundation foot
Shouldered bolt	487242779	2	G	M10 x 80, lock for front foundation foot
Locking nut	732212001	2	G	M10, lock for front foundation foot
Actuator	487028988	2	H	
Centre bolt	487242799	4	J	M8 for clamping actuator
Locking nut	732211801	4	J	M8 for clamping actuator
Bevel washer	734116431	4	J	M8 for clamping actuator
Left side skirt	487242788	1	M	
Right side skirt	487242775	1	M	
Clip screw	487242796	6	Mm	M5 for mounting in side skirts
Nut	731231401	6	Mn	M5 for clip screws in side skirts
Back skirt	487240222	1	O	
Front cross bearer	487240221	1	N	Front skirt
Top nut	487242797	4	Q	M5 for back skirt
Plate screw	471834033	12	P	4.8 x 13 (Torx)
Connecting piece	487240611	1	L	For outlet pipe 315 mm — 303 mm / 12"
Bits extension piece	487242254	1	LI	For mounting outlet pipe

7.3 Installation

The machine shall be mounted on a concrete floor with a thickness of at least 100 mm / 3 15/16 inch. Make sure the floor is in level.

Place the 2 mounting base sides (A) (fastened on wooden pallet with 4 transportation screws which should be removed) on the concrete floor, where the machine is going to be mounted.

* = Front of the machine.

** = Rear of the machine.

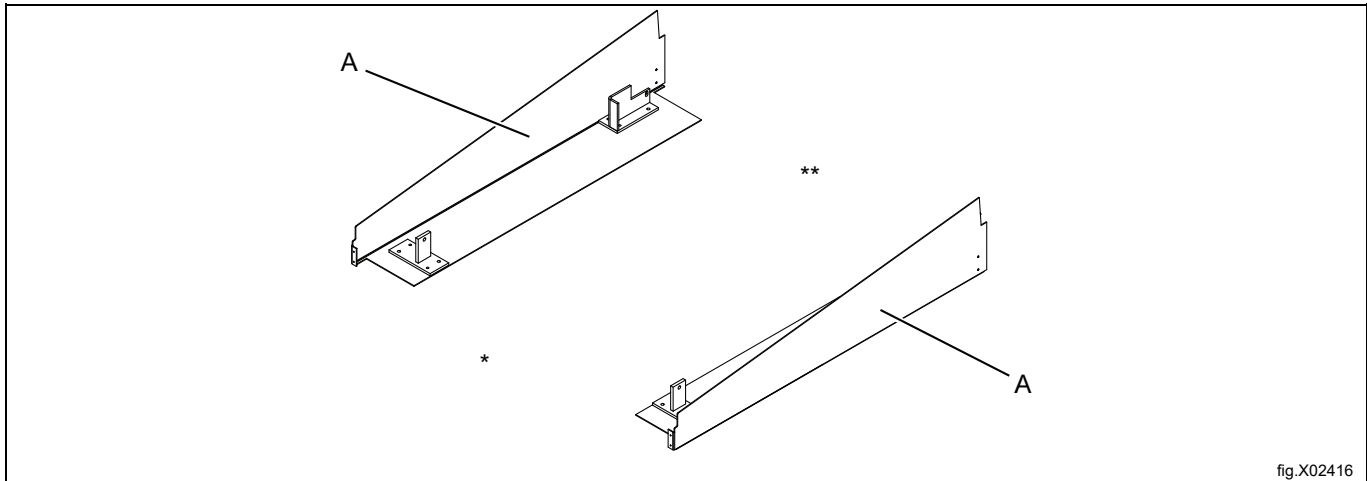

Pre-mount the mounting base front piece (B) and the mounting base back piece (C) on the mounting base sides with screws (P).

Cross measure between the foundation feet (F1 = F2) making sure the mounting base is square.

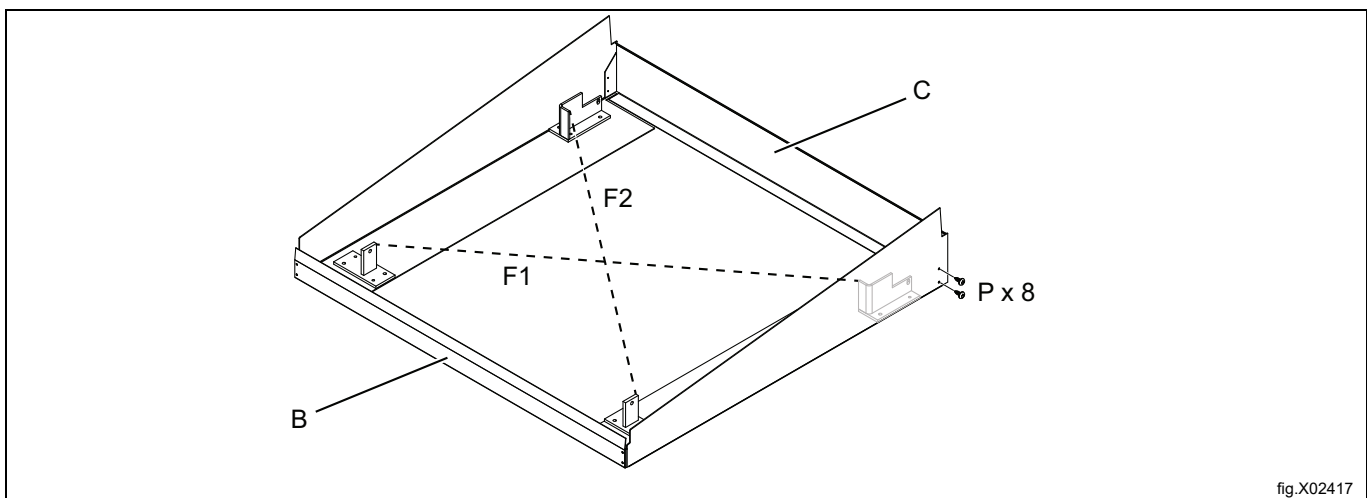

Mark out the 8 holes. Move the complete mounting base and drill the 8 holes $\varnothing 8 \times 100$ mm.
 Insert the 8 expansion bolts (R) into the floor.
 Put the complete mounting base back in position on the expansion bolts.

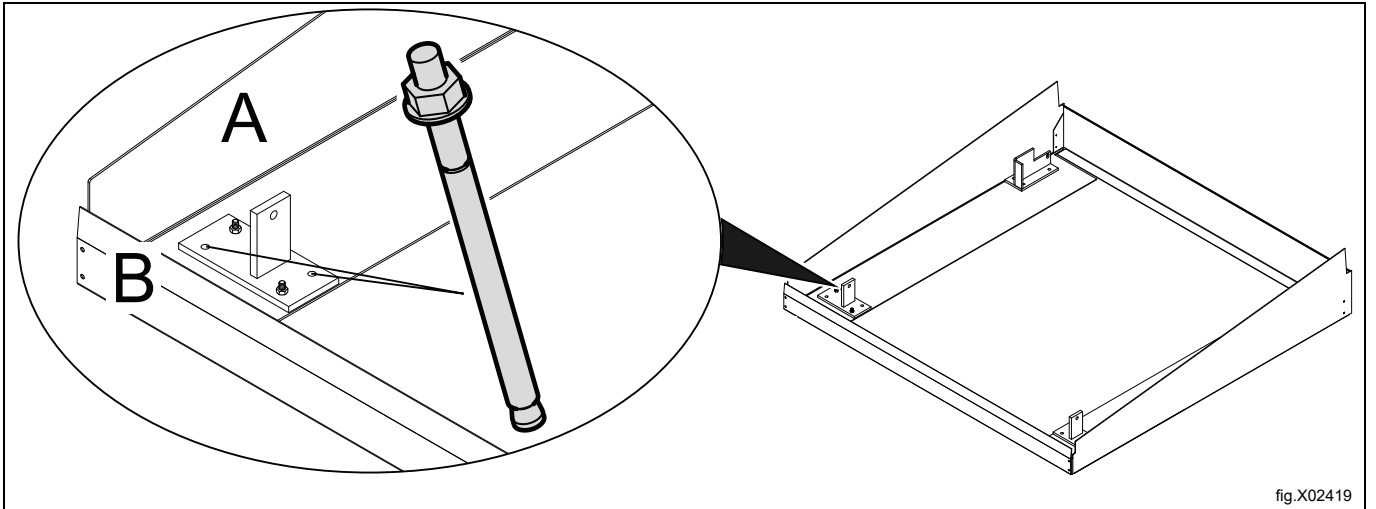

fig.X02419

For alignment use the adjusting plates (D), as an underlying layer.

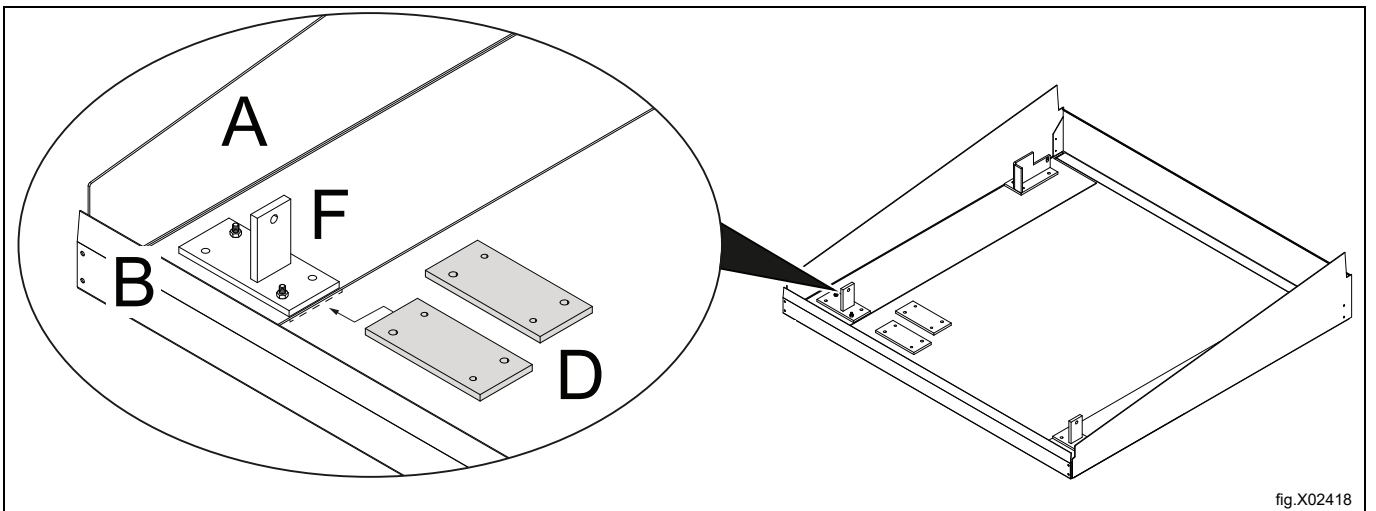

fig.X02418

When the complete mounting base is in position and in level fasten the 8 expansion bolts,
 Before continuing, the mounting base front piece (B) and the mounting base back piece (C) shall be demounted.

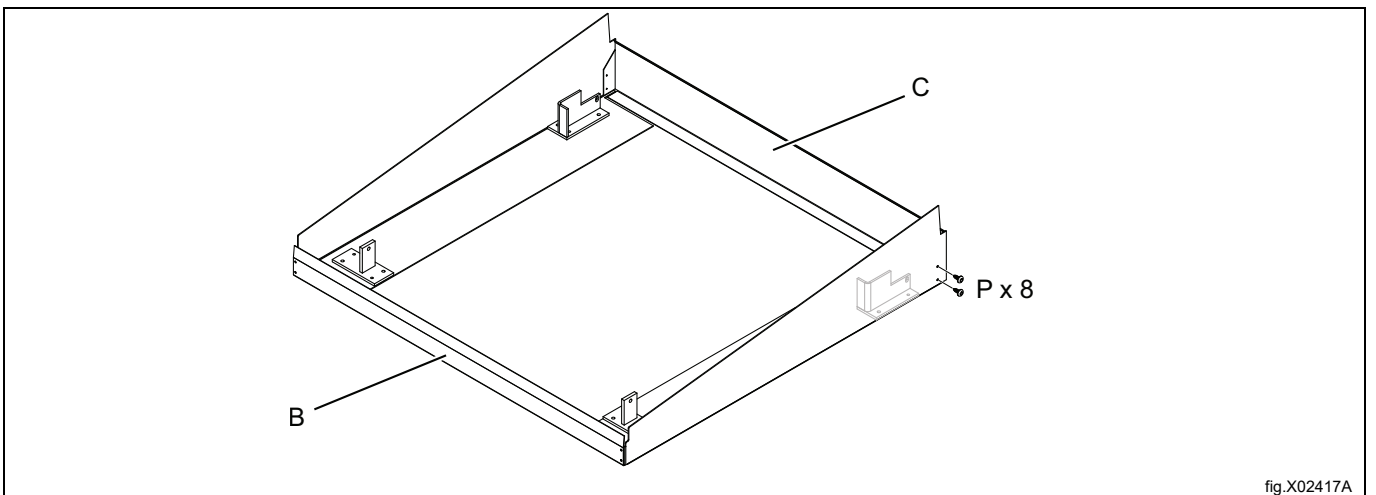

fig.X02417A

Control measure; the mounting base must be diagonally level and the mounting base sides must be parallel.
It is important to be careful when aligning the mounting base.
If necessary use adjusting plates (D).

Note!

If the mounting base is crooked the sliding door and the tilting function will not work properly.

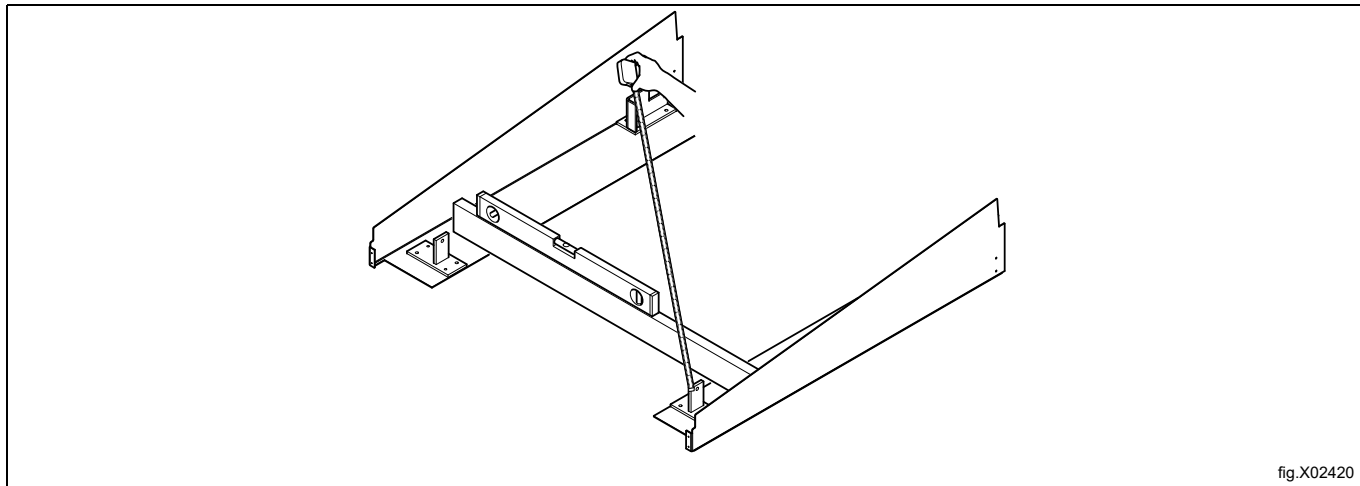

fig.X02420

Remove the filter door (T).

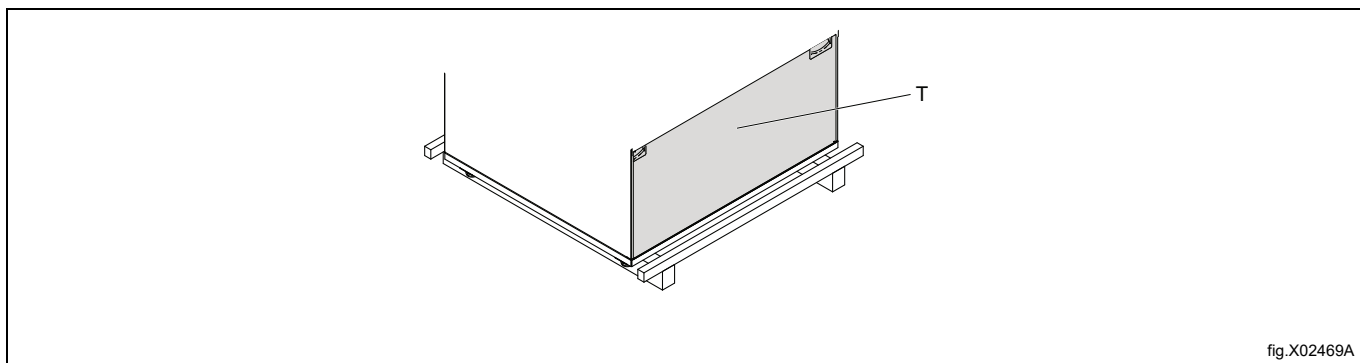

fig.X02469A

Remove the two wooden bars, one in the front and one in the back.

For further information about the unpacking, please refer to the section [Unpacking](#).

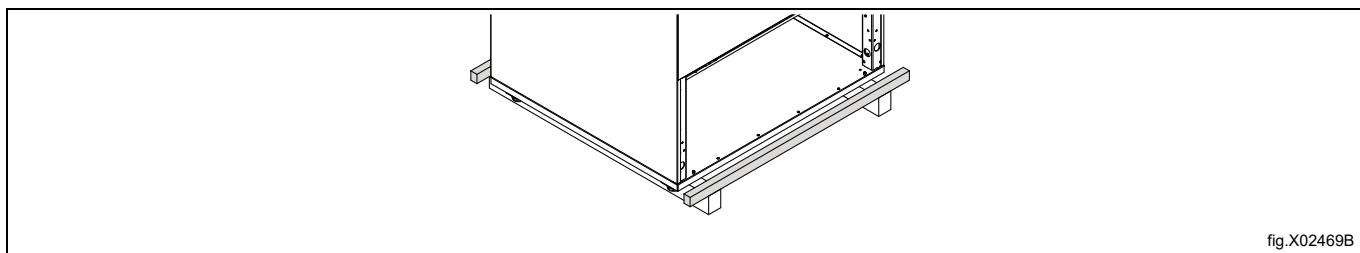
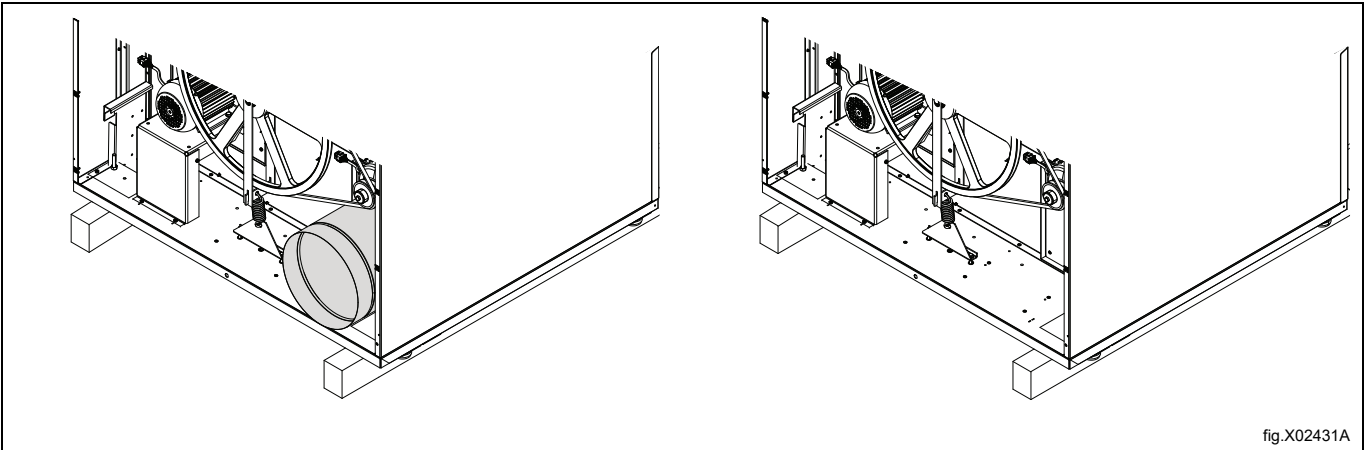
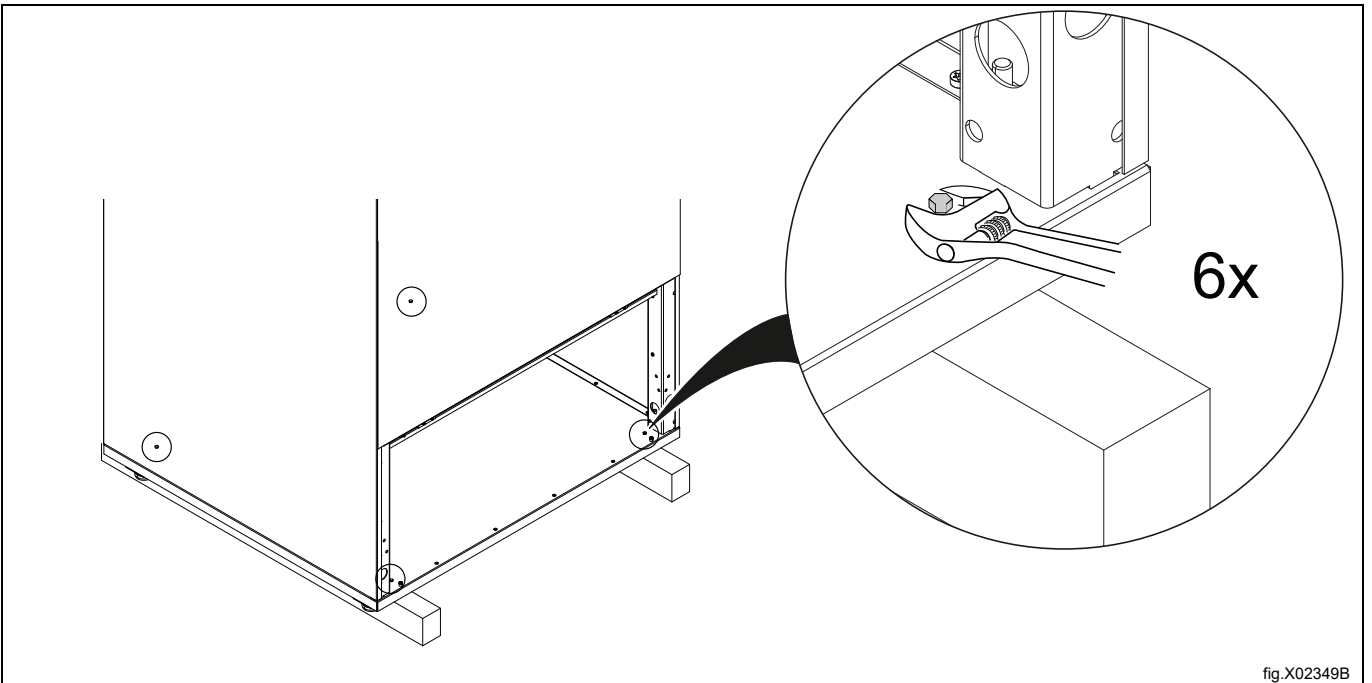

fig.X02469B

Demount the outlet pipe. Use the supplied bits extension piece (LI) for demounting the outlet pipe.



Remove the bolts between the machine and pallet.



Lift the machine with for example a fork-lift truck and remove the wooden bars.

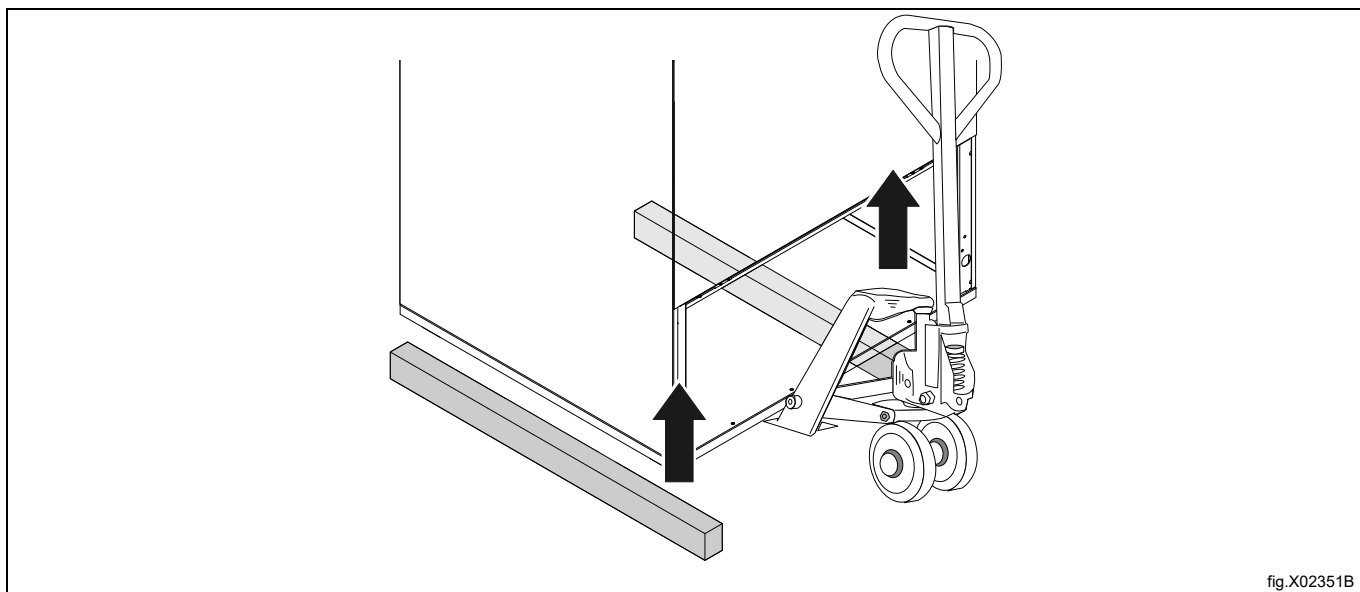

fig.X02351B

Pre-mount the 2 front guiding consoles (E) with the foundation bolts M20 (E). Do not tighten the bolts.

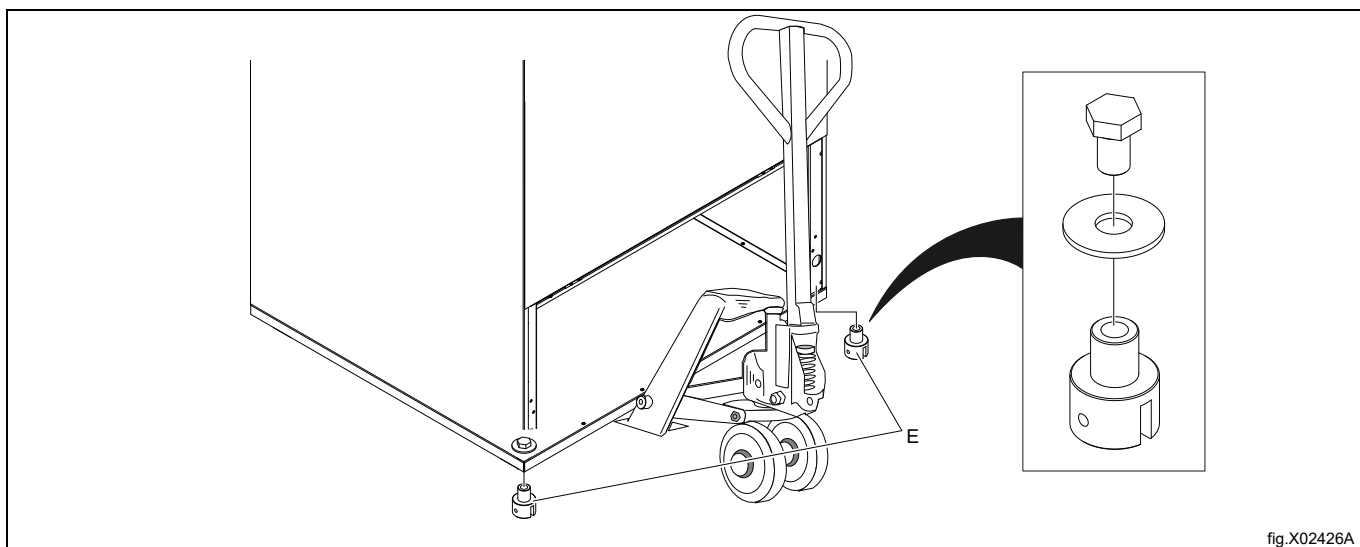
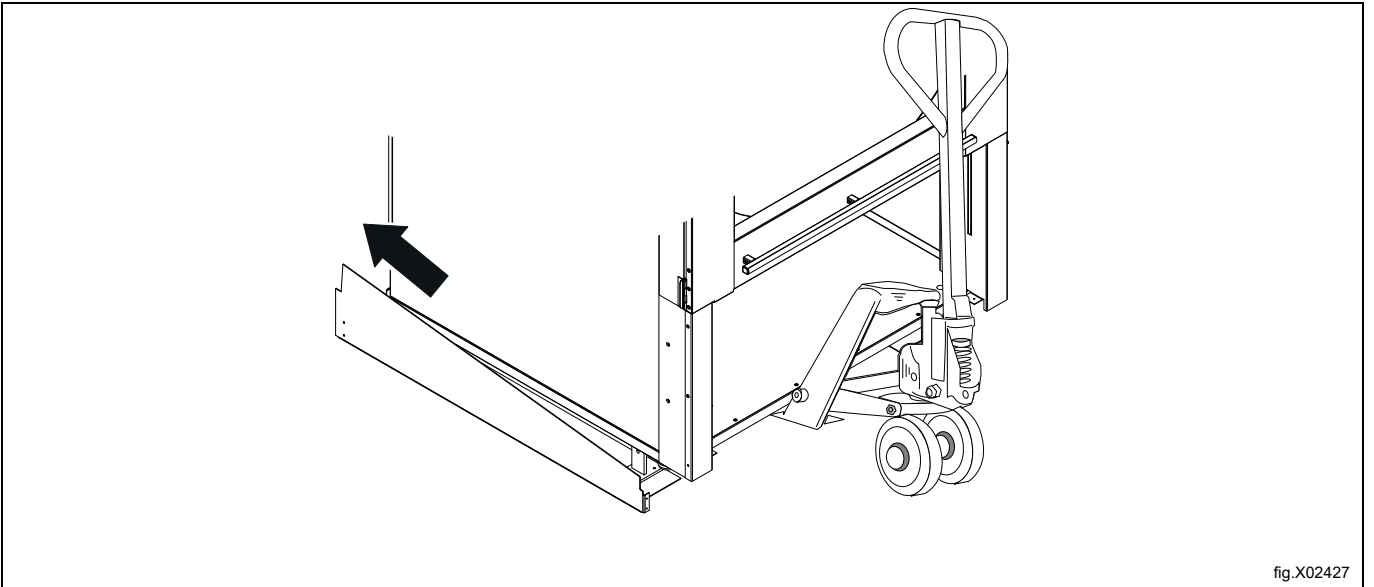
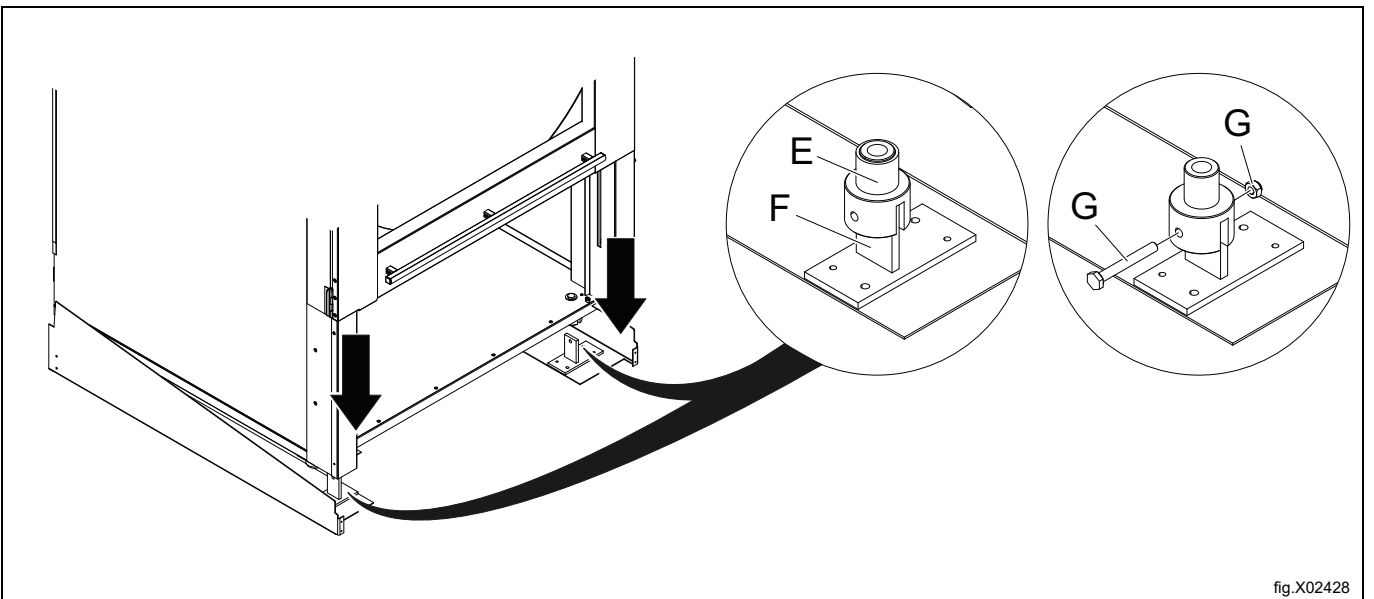

fig.X02426A

Position the machine above the 2 mounting base sides.



Carefully lower the machine so the guiding consoles (E) engage with the foundation feet (F).
Insert the 2 locking bolts (G) and tighten them.



Remove the fork-lift truck.

When the fork-lift truck is removed the two remaining support sections are disengaged and shall be removed.

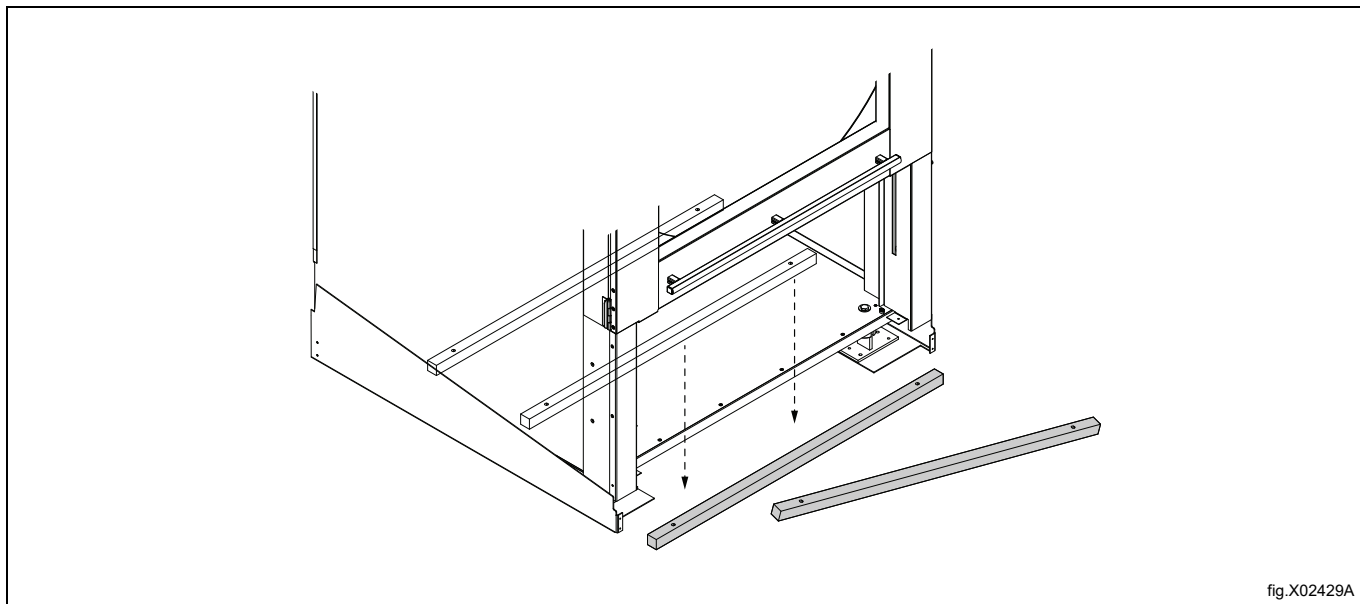

Tighten the 2 foundation screws (E).

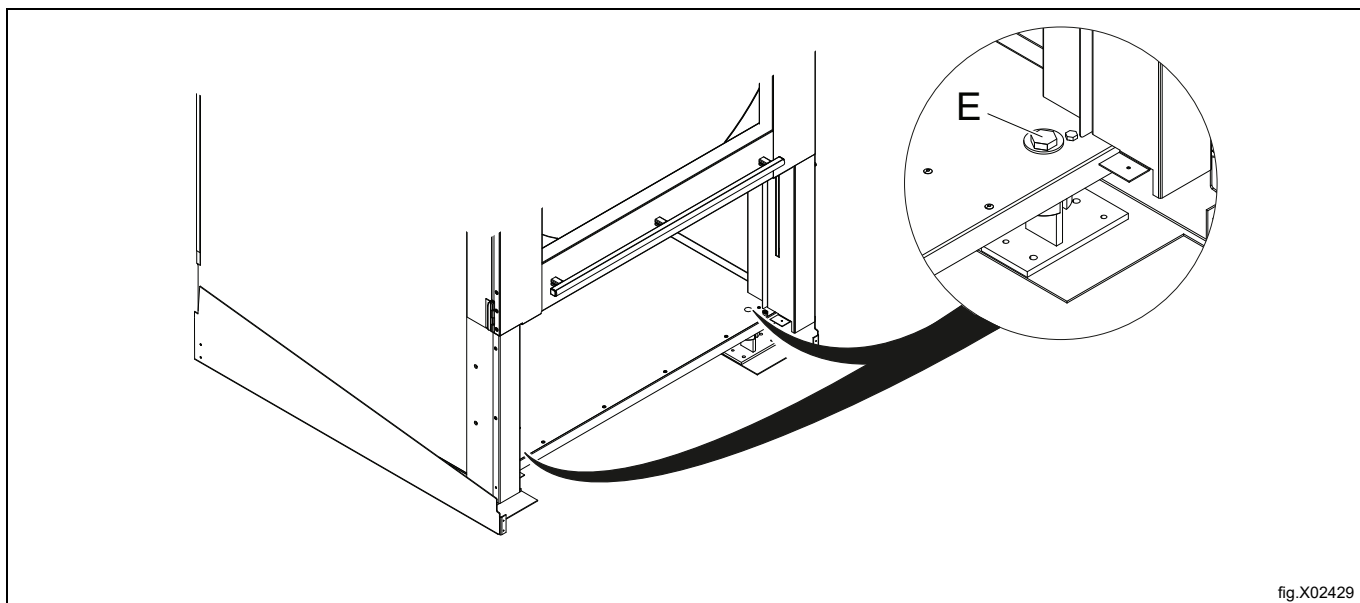

Mount the mounting base front piece (B) with screws (P).

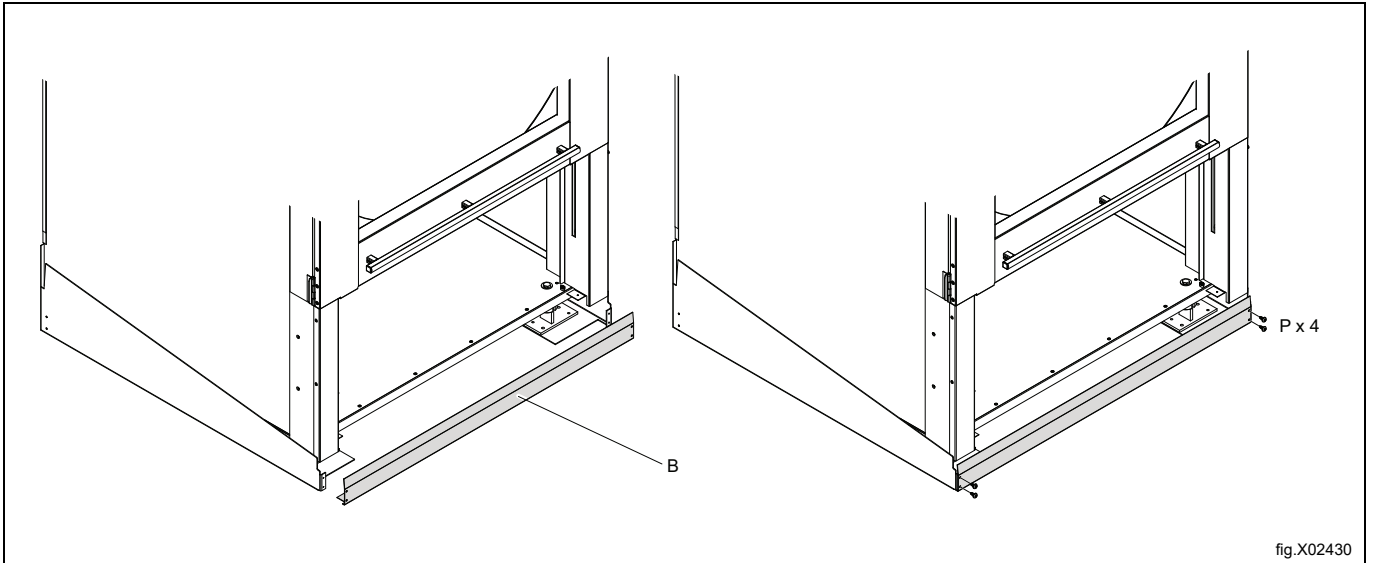

fig.X02430

Mount the 2 actuators (H) on the back foundation feet (F) by tilting them through the 2 square openings. Fasten the actuators with 2 centre bolts, washers and locking nuts (J).

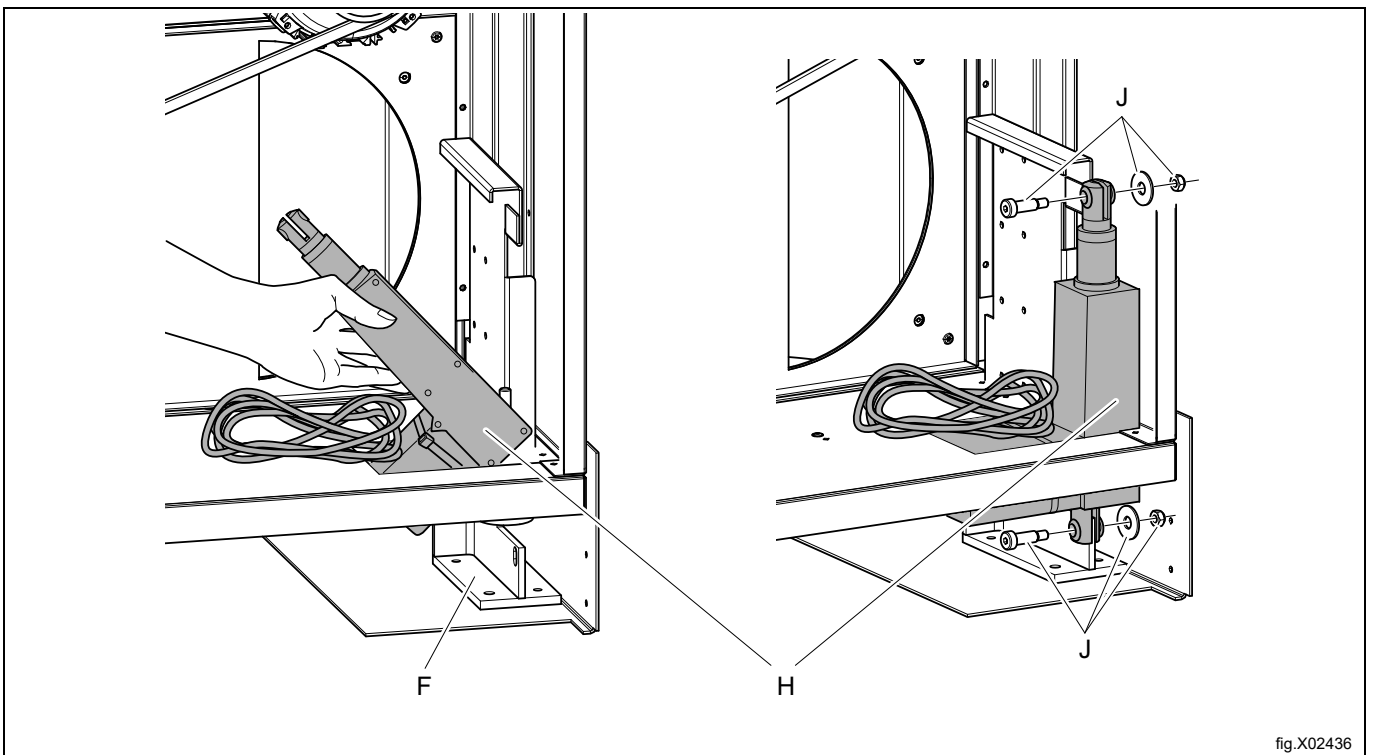

fig.X02436

Due to the tilting function the cables must have an excessive length of 300 mm (A).
Fasten the actuator cables with the pre-mounted cable ties (Hh).

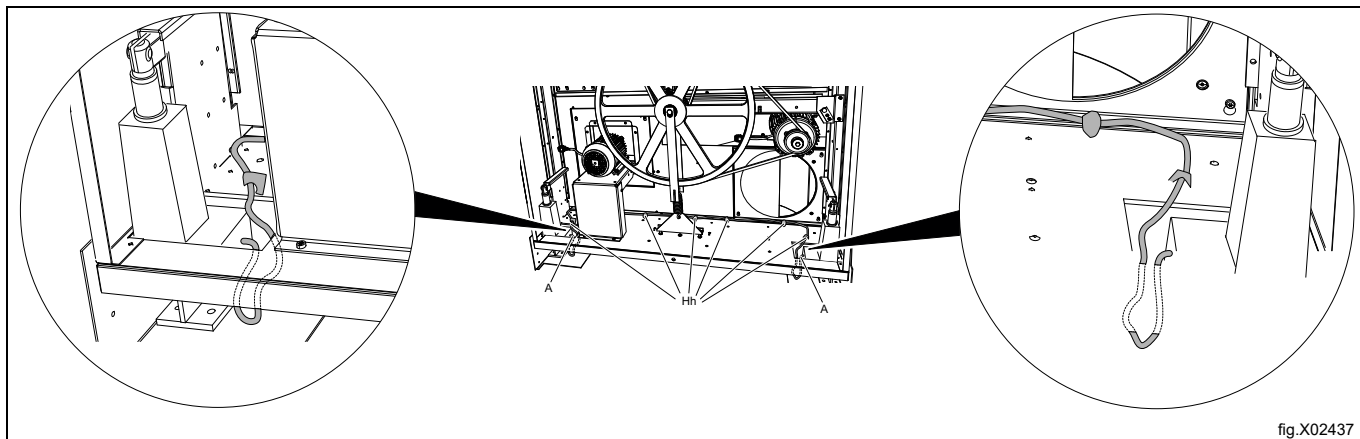

fig.X02437

Place the 2 multiple plugs (K) from the actuators in the control box.

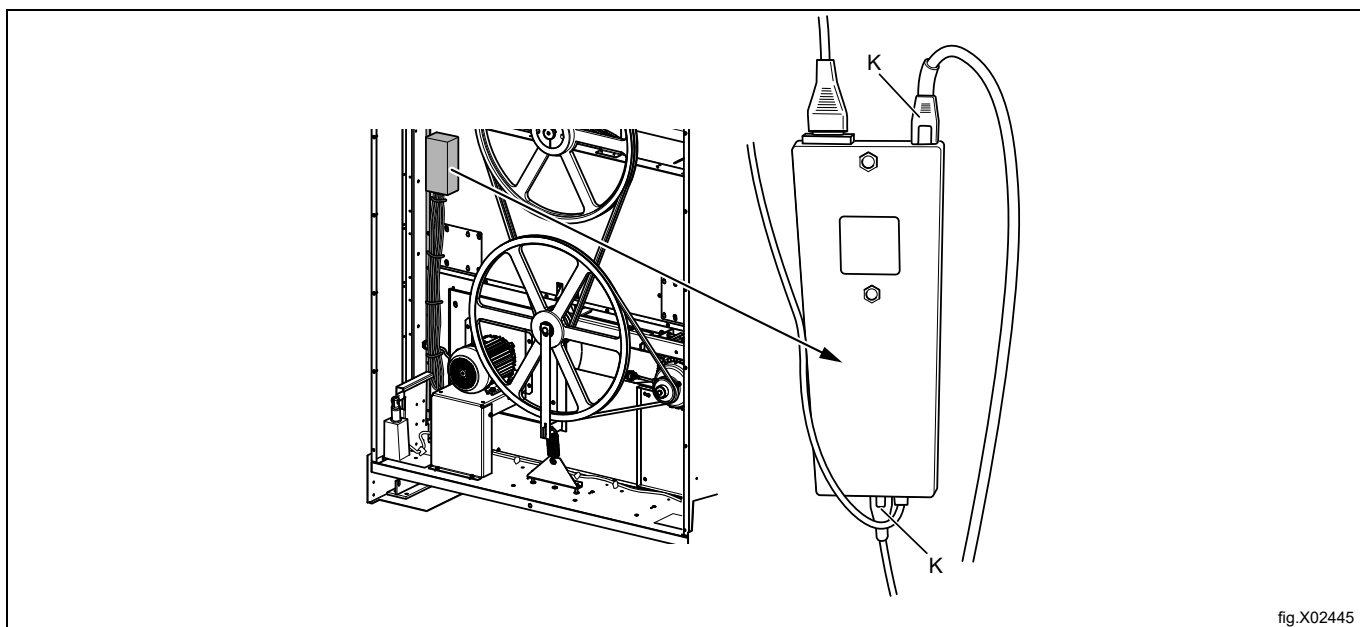
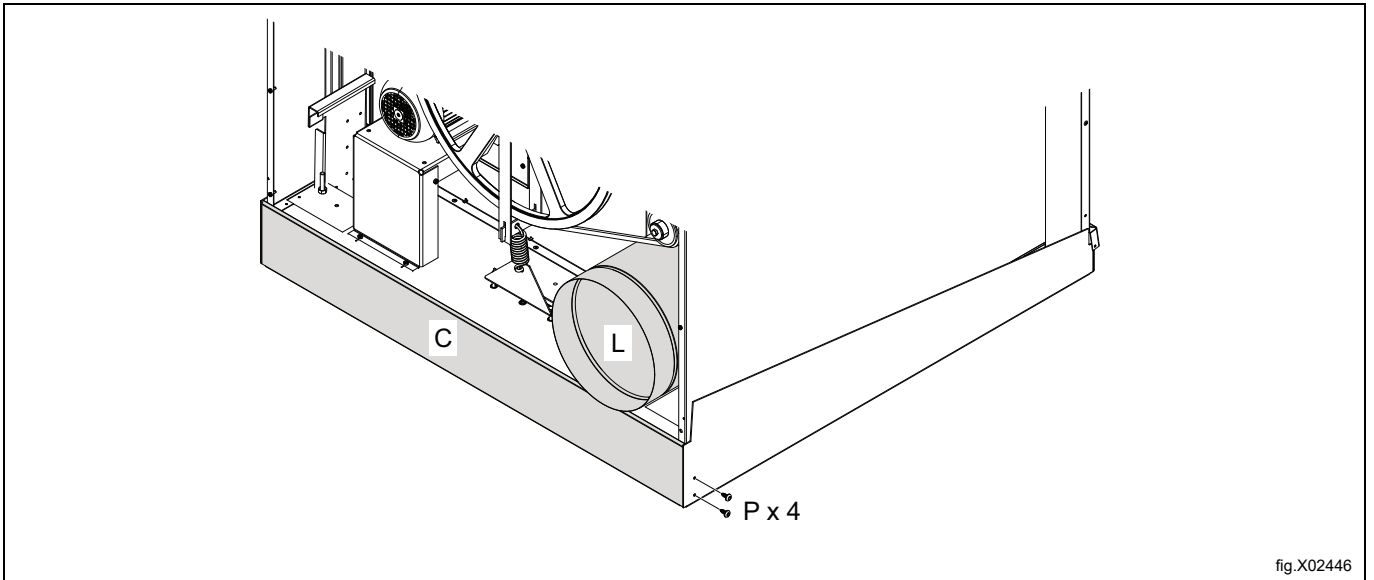

fig.X02445

Mount the back mounting base piece (C) with screws (P).

Mount the outlet pipe (L). Use the supplied bits extension piece for mounting the outlet pipe.



Mount 3 clip screws (Mm) in both side skirts.

The clip screws shall be pressed angled into the square openings and slid up to lock in correct position.

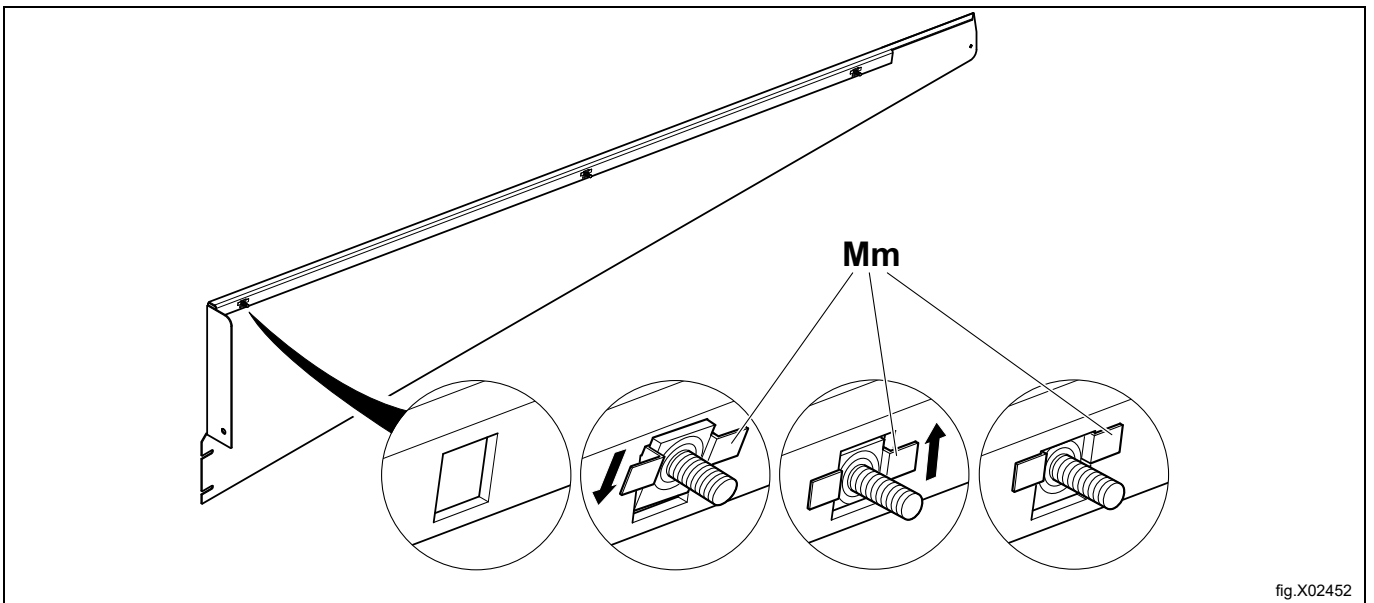

Mount the side skirts (M) and the cross bearer/front skirt (N) with screws (P).

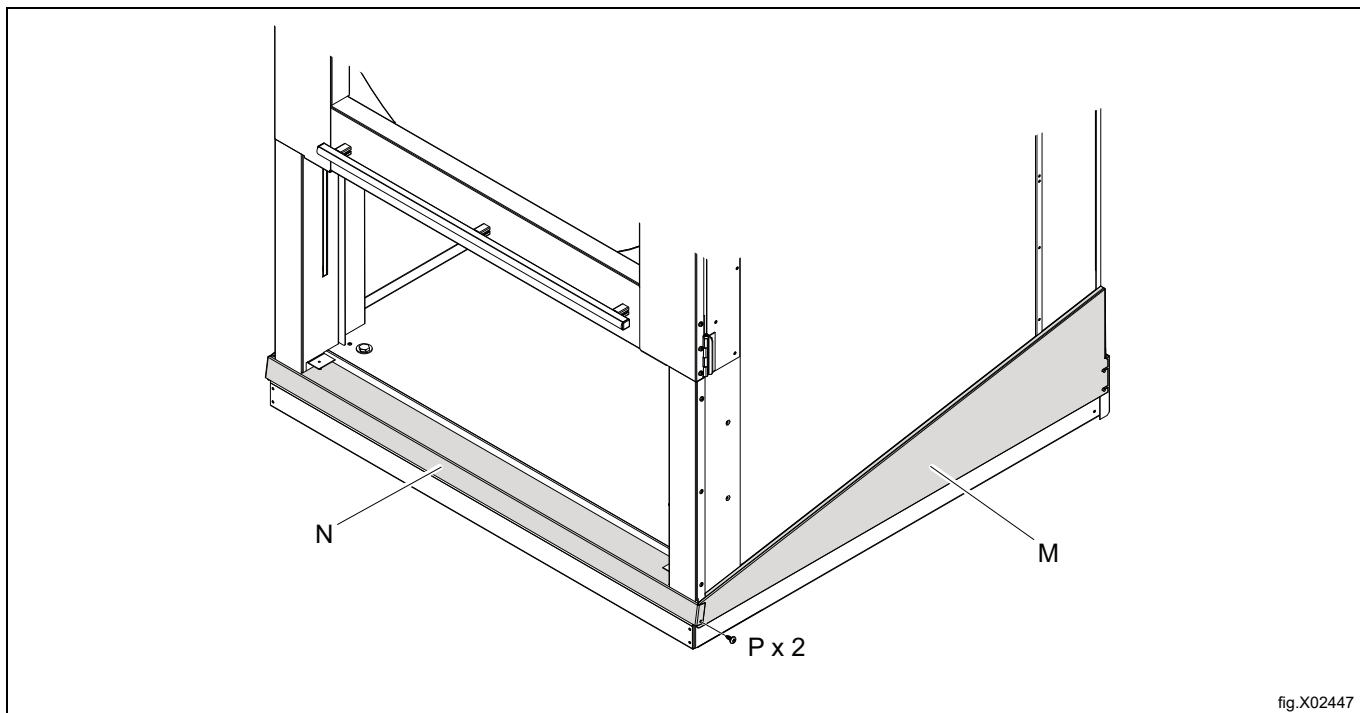

fig.X02447

Mount 3 nuts (Mn) inside of the machine to lock the side skirts (M).

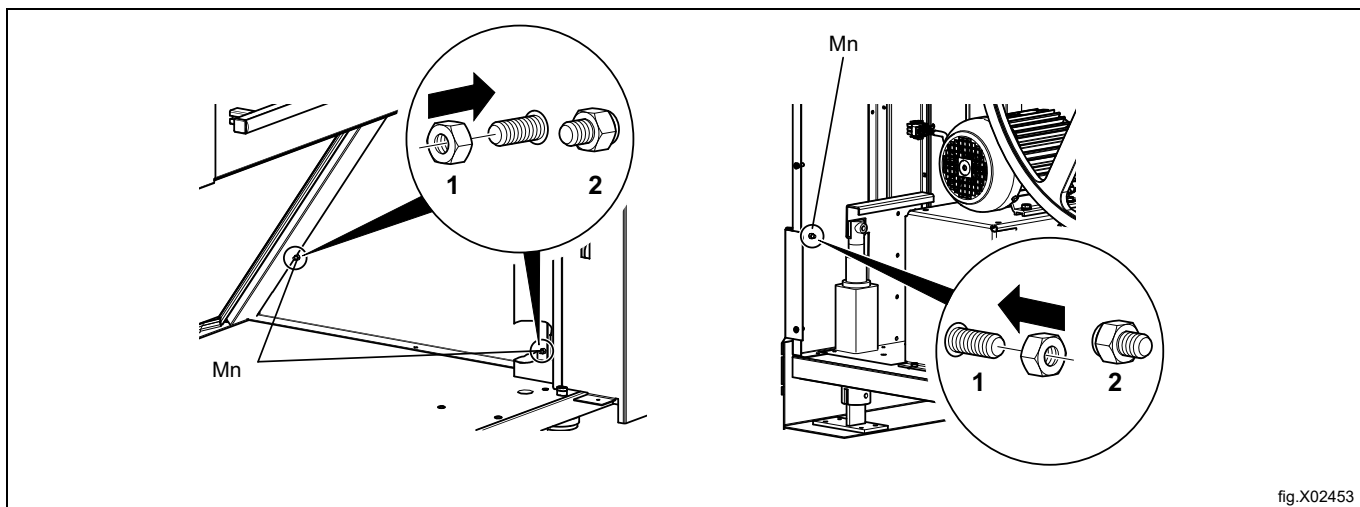
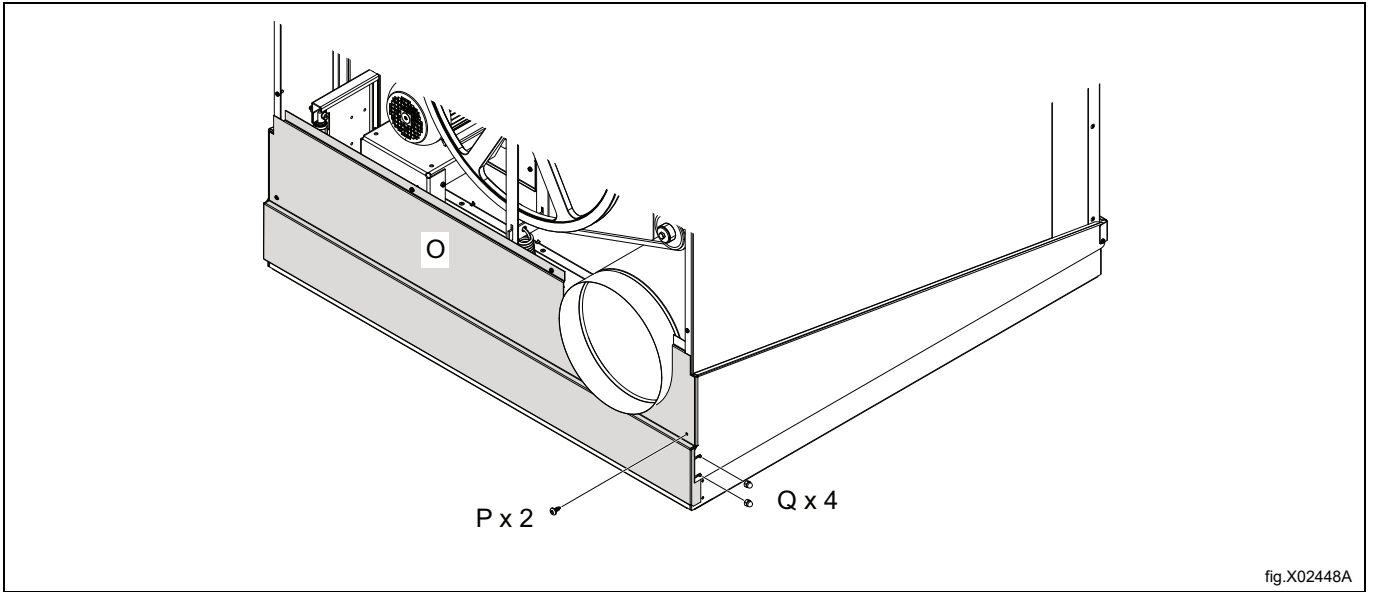
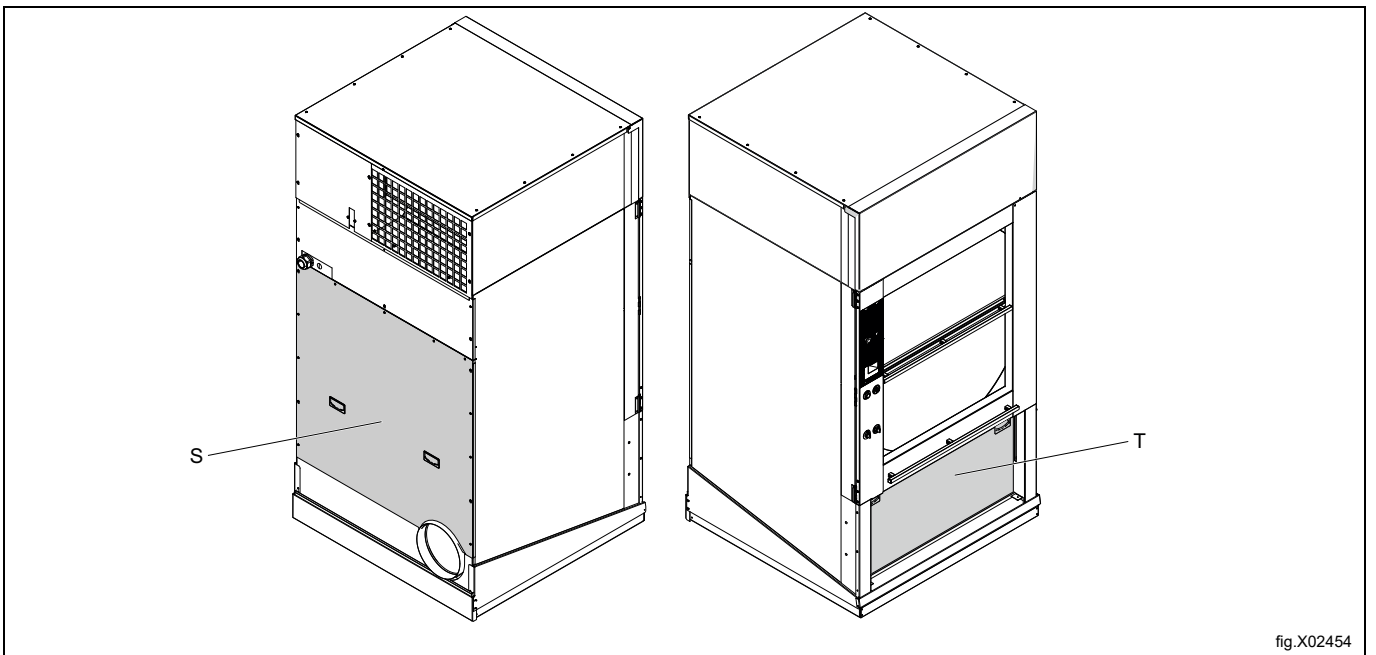

fig.X02453

Mount the back skirt (O) with 2 screws (P) and 2 top nuts (Q).



Mount the rear panel (S) and remount the filter door (T).



When ready, the machine shall look like the figure and the tilt function can be used.

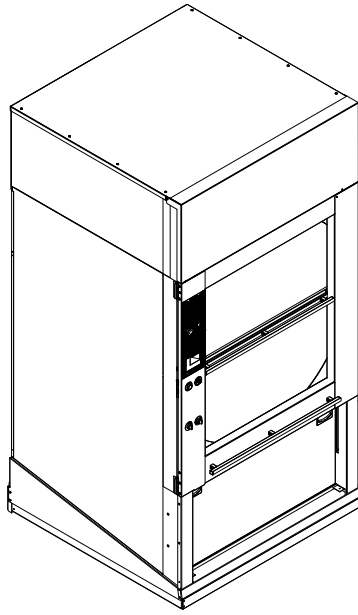

fig.X02455

8 Evacuation system

8.1 Air principle

The blower creates low pressure in the machine, drawing air into the drum via the heating unit.

The heated air passes through the garments and the drum holes.

The air then flows out through a lint filter positioned immediately below the drum. After this, the air is evacuated through the blower and exhaust system.

Note!

It is very important that the machine gets enough fresh air in order to get the best drying result.

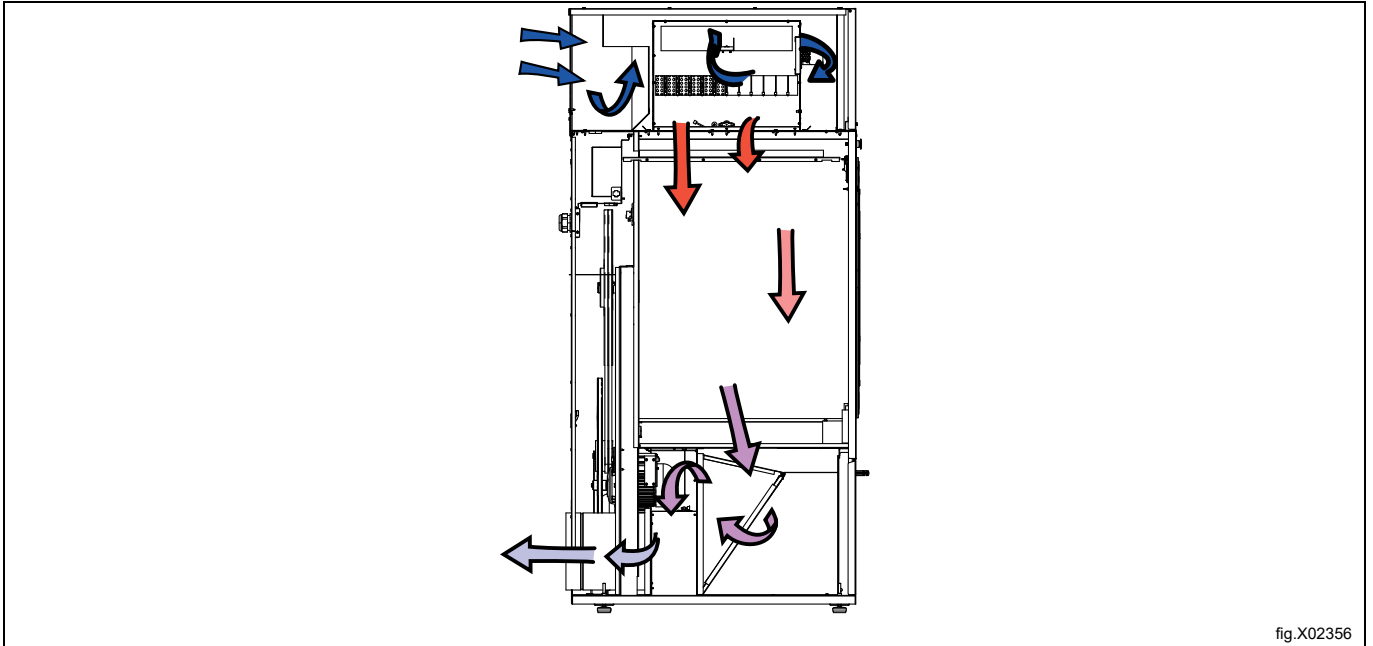

fig.X02356

8.2 Fresh air

For maximum efficiency and the shortest possible drying time, it is important to ensure that fresh air is able to enter the room from the outside in the same volume as that is blown out of the room.

To avoid draught in the room it is important to place the air inlet behind the machine.

Provisions for adequate air supply: The area of the air inlet opening should be five times the size of the exhaust pipe area. The area of the inlet opening is the area through which the air can flow without resistance from the grating/slatted cover.

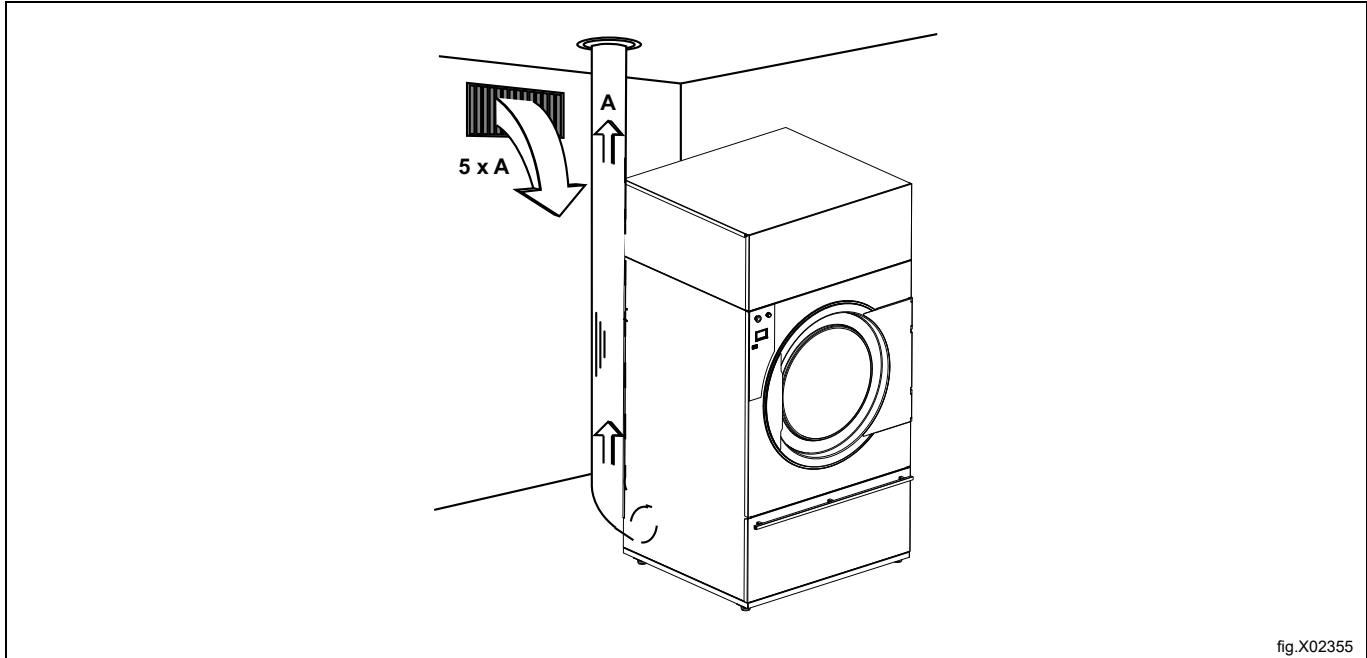

The resistance in the grating/slats on the air inlet cover plate should not exceed 10 Pa (0.1 mbar).

Note!

Gratings/slatted covers often block half of the total fresh air vent area. Remember to take this into account.

8.3 Exhaust duct

- Only rigid or flexible metal duct should be used for exhausting.
- Plastic ducting is not to be used.
- Recommended material for exhaust is galvanized steel.
- The duct is not to be assembled with screws or other fastening means that extend into the duct and catch lint.
- The exhaust air should not be vented into a wall, a ceiling, or a concealed space of building.
- The exhaust duct must lead clear of the building as condensation may cause frost damage to the building.
- The exhaust duct must lead to the outdoors.
- The exhaust duct must be placed in such a way that it is protected on the outside.
- The exhaust duct must be smooth on the inside (low air resistance).
- The exhaust duct must have gentle bends.

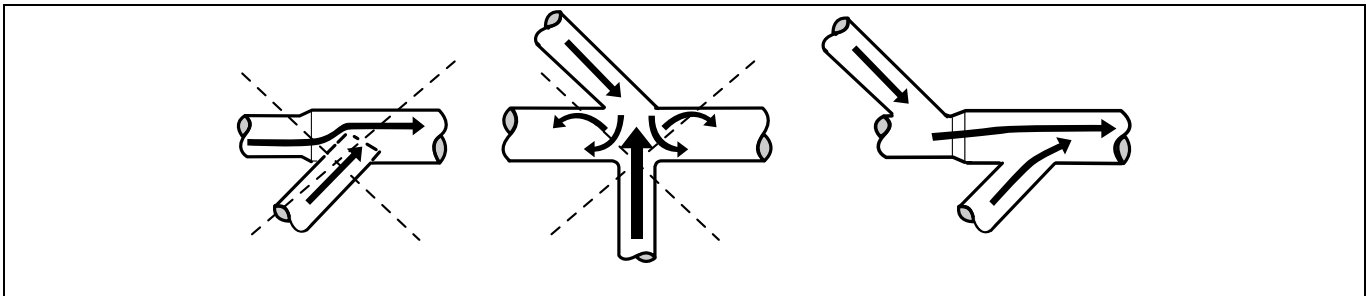

8.4 Shared exhaust duct



It is recommended that each machine is connected to a separate exhaust duct.



When several machines shall use the same exhaust duct the exhaust duct must increase after each machine. The recommended diameter increase progression is the one in the table. Please consider that unnecessarily large ducts create issues with the draught.

The exhaust duct must have a nonreturn flap after each dryer.

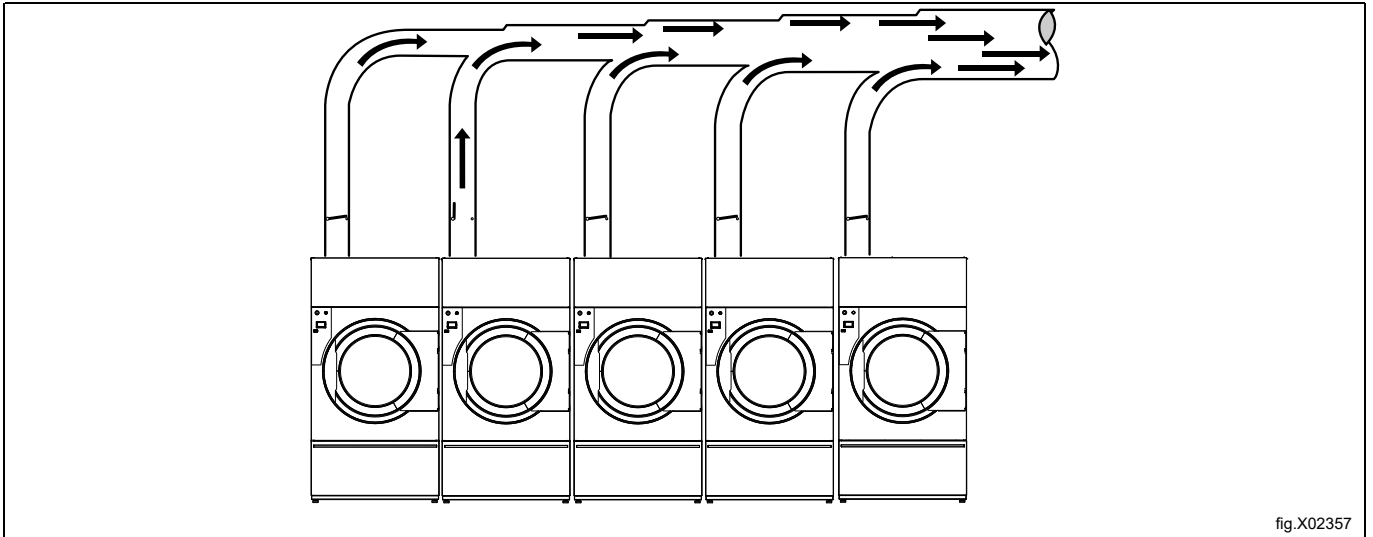

fig.X02357

Number of machines		1	2	3	4	5	6	7	8	9	10
Exhaust duct	∅ mm	315	500	630	630	800	800	1000	1000	1000	1000
Recommended area of fresh air intake	m ²	0.39	0.98	1.56	1.56	2.51	2.51	3.93	3.93	3.93	3.93
Minimum area of fresh air intake	m ²	0.27	0.54	0.81	1.08	1.35	1.62	1.89	2.16	2.43	2.7



The exhaust duct diameter must not be reduced.



8.5 Exhaust dimensioning

It is important that the machine has correct air volume compared to each machines power.

If the air flow is smaller or larger this will result in a longer drying period.

If the outlet pipe is long or the ventilation is not properly designed we recommend to clean the outlet pipes periodically. Usually, longer ducts need more frequent cleaning.

The exhaust pipes shall be short in order for the machine to work in the best way.

All cover panels must be mounted in order for the machine to work in the best way.

8.6 Adjusting the air flow



Adjusting the air flow may only be carried out by authorized personnel.

It is important that the machine has the correct air flow compared to each machines heat input. If the air flow is below the minimum, the machine will be forced to switch the heating off which will result in longer drying time.

An air flow above needed is unnecessary and can result in a cold laundry room and noise from the piping and outlet. In extreme causes this can result in longer drying time.

The optimum drying performances are achieved when the measured static back pressure correspond to the value listed in the following table.

TD6-45

Heating	Effect	Hz	Optimum static back pressure — measured at position A (Pa) in a cold empty machine		Resulting: Nominal air flow in a cold empty machine (m ³ /h)	
			STD ¹	SLD ²	STD ¹	SLD ²
Electric	60 kW	50	435	150	1815	2145
Gas	63 kW	50	350	—	1815	—
Gas	63 kW	60	1230	—	1518	—
Steam	60 kW	50	490	—	1804	—

1. Standard machine

2. Machine with sliding door

TD6-60

Heating	Effect	Hz	Optimum static back pressure — measured at position A (Pa) in a cold empty machine		Resulting: Nominal air flow in a cold empty machine (m ³ /h)	
			STD ¹	SLD ²	STD ¹	SLD ²
Electric	72 kW	50	1120	—	1782	—
Gas	83 kW	50	900	940	2068	1914
Gas	83 kW	60	150	—	2321	—
Steam	80 kW	50	640	640	2178	2178

1. Standard machine

2. Machine with sliding door

For piping systems which deviate from this provided data it is necessary to adjust the piping system.

Note!

The adjustable air damper is not supplied with the machine from factory.

Checking the back pressure

Demount the lower rear panel.

Demount the heating sensor (NTC sensor) (A) and insert the measuring device. Make sure the connection is tight to prevent air leakage.

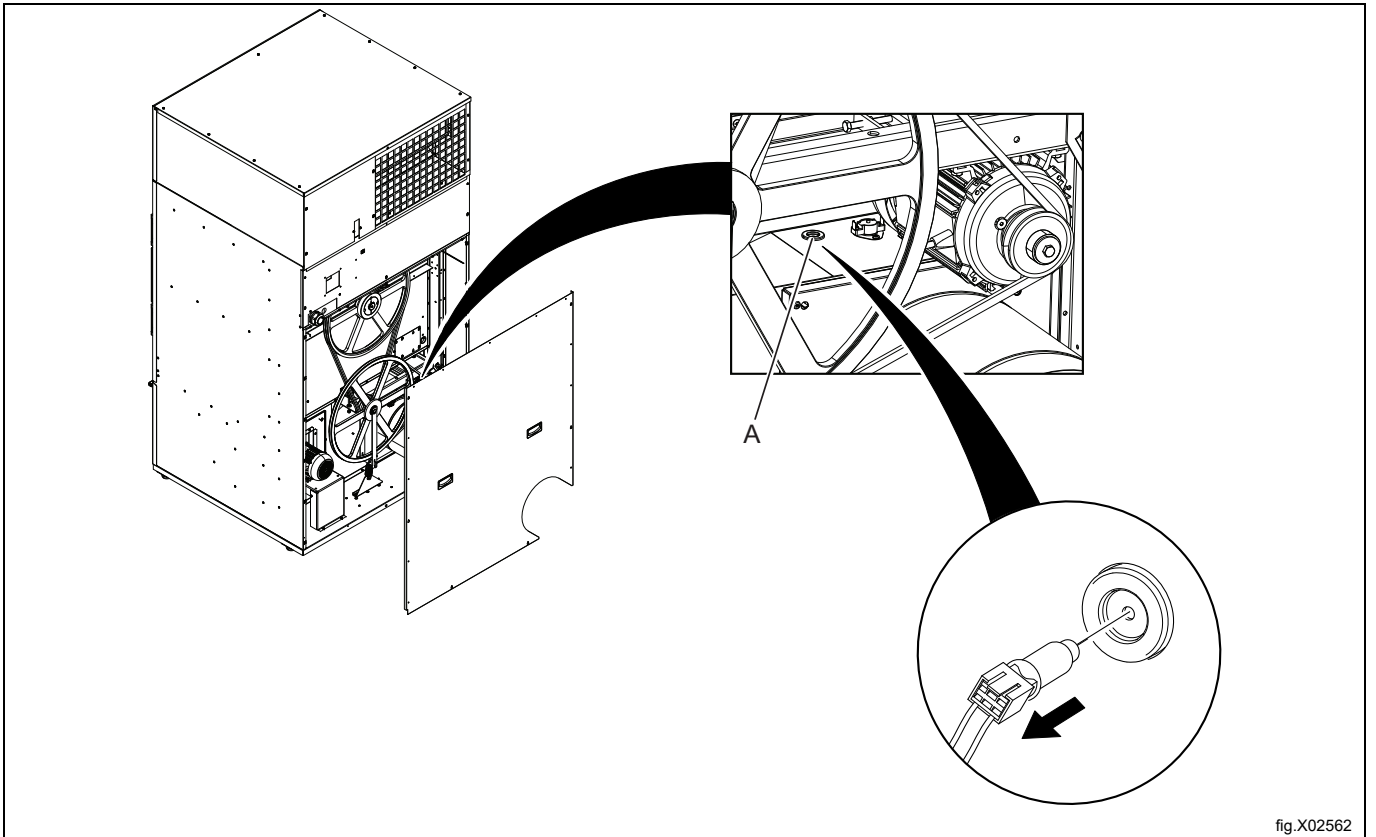

fig.X02562

Alternative measuring method

Adjusting the air flow may only be carried out by authorized personnel.

Use a home made U tube manometer, a hose (max. outer \varnothing 10 mm and min. outer \varnothing 5 mm), with water. Insert one end of the hose in the hole (A) (after the NTC-sensor has been removed), hold the hose according to the picture so that the water is in level.

Start the machine and measure the difference between the water in one of the hose ends with the other.

1 mm = 10 Pa.

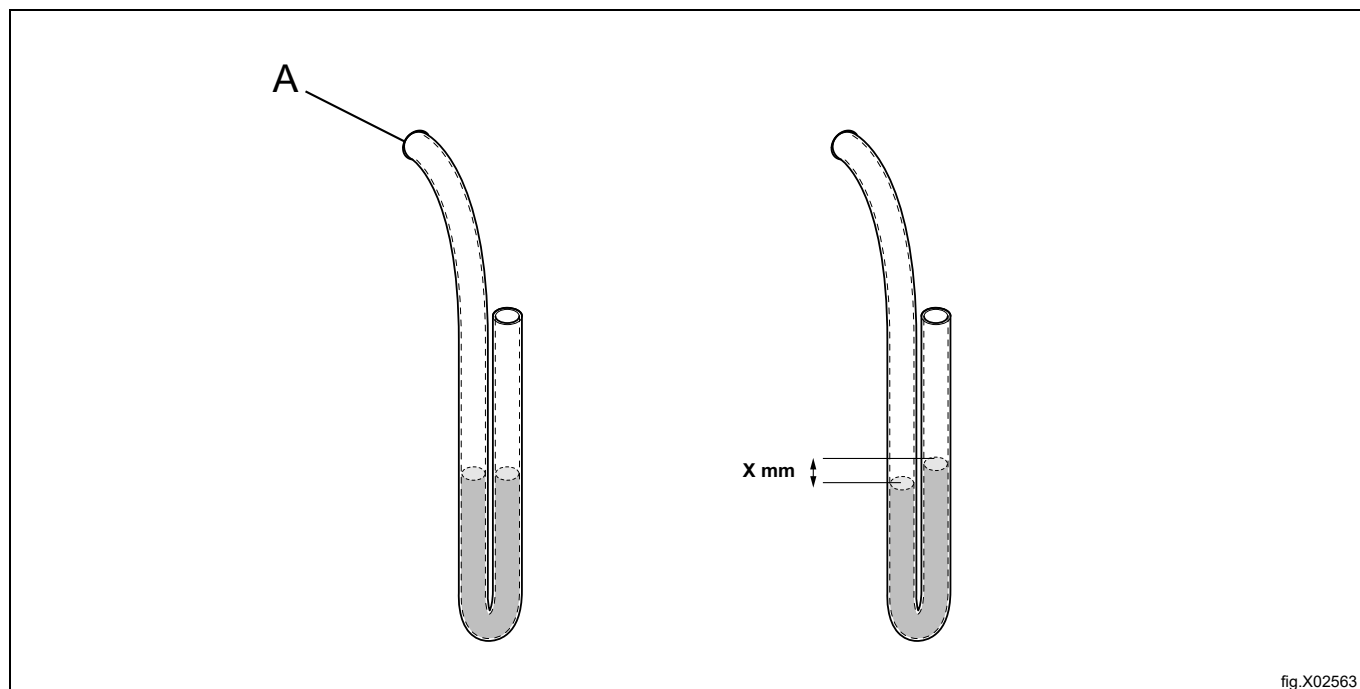

fig.X02563

When the back pressure is according to recommended value, remount the heating sensor (NTC sensor) (A).
Remount the lower rear panel.

Diagram with pressure drop curve

The grey area (A) illustrates the optimal working area.

A	Working area
B	Optimum airflow cold empty machine
C	Static back pressure, Pa
D	Air flow m ³ /h

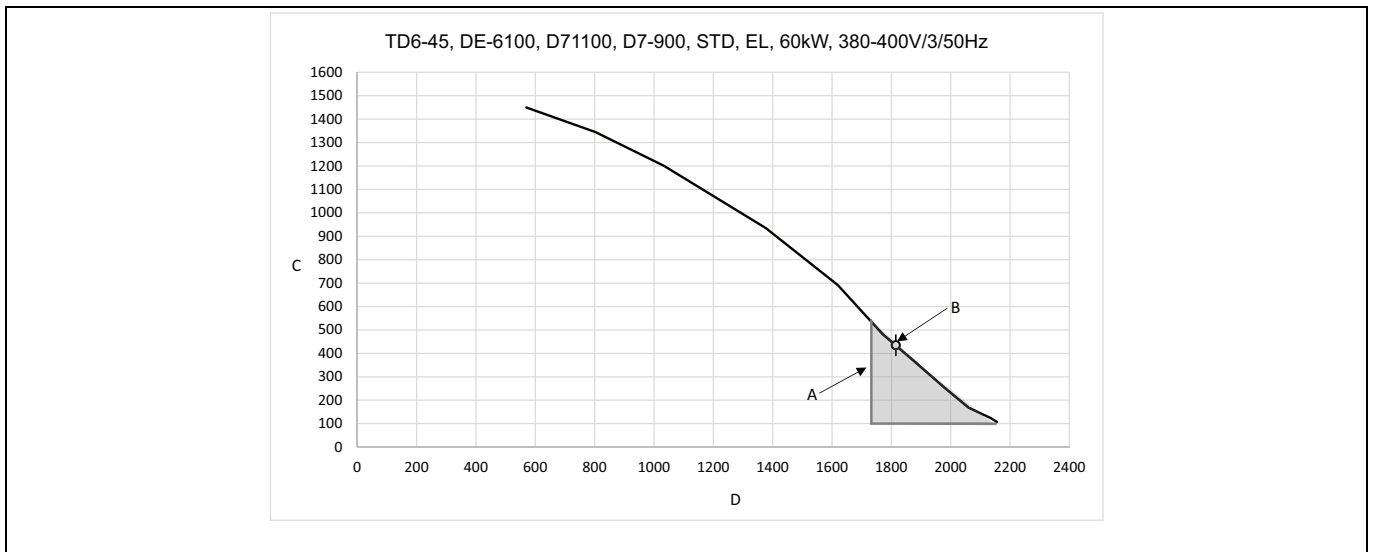
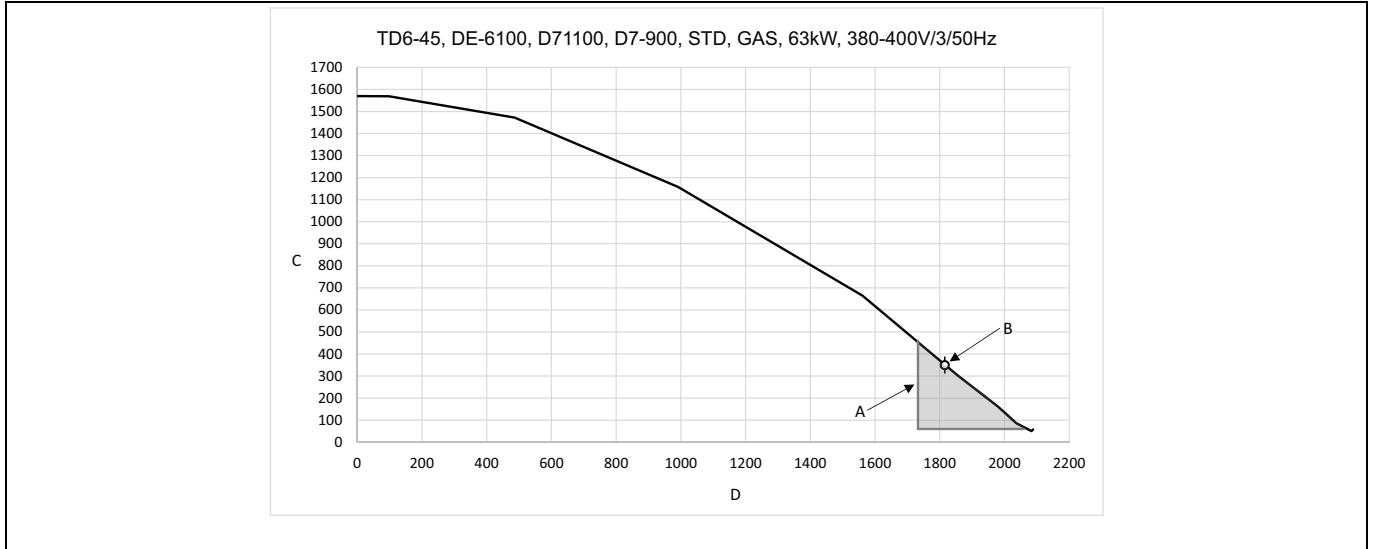

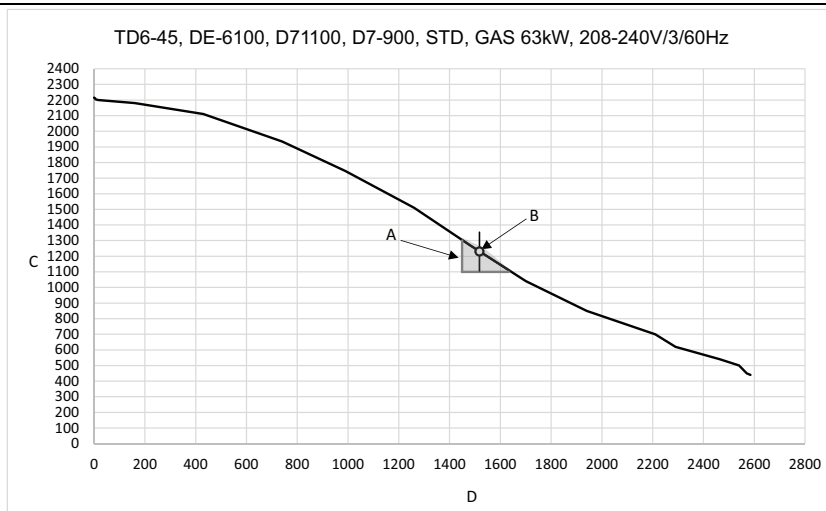
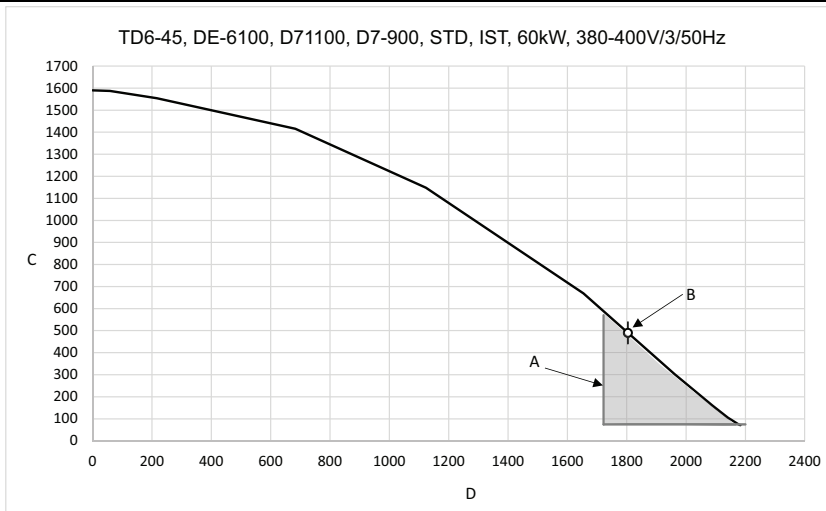
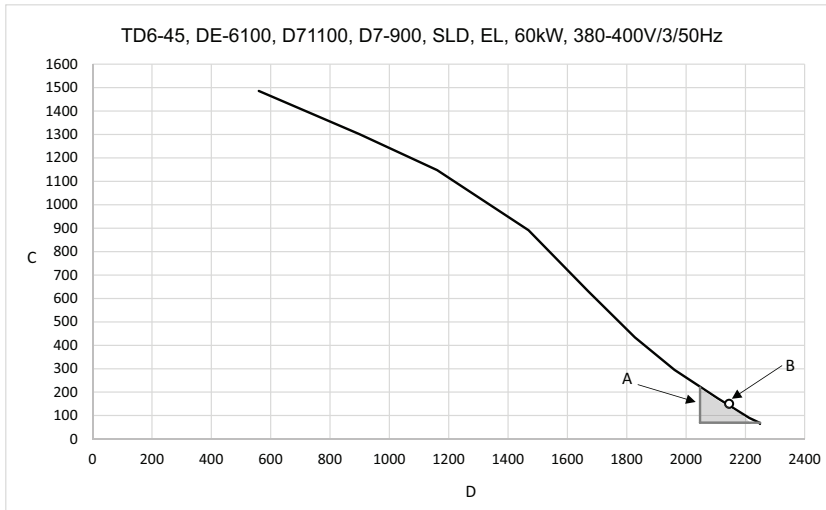

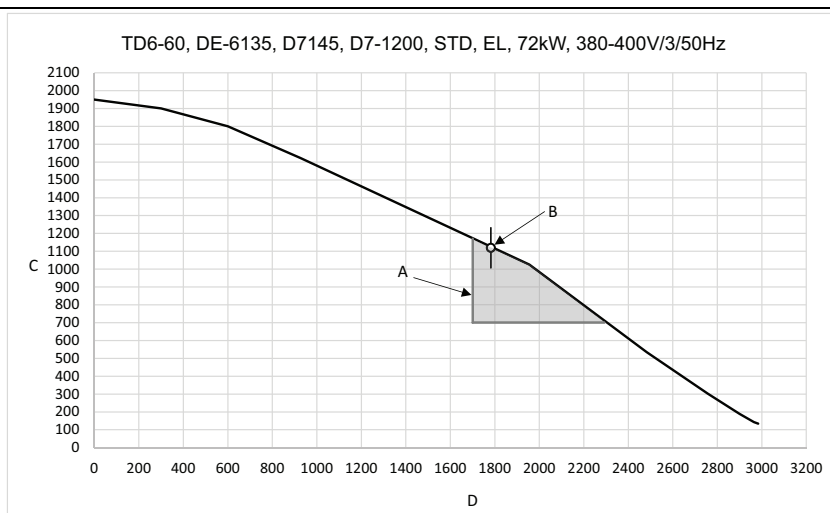
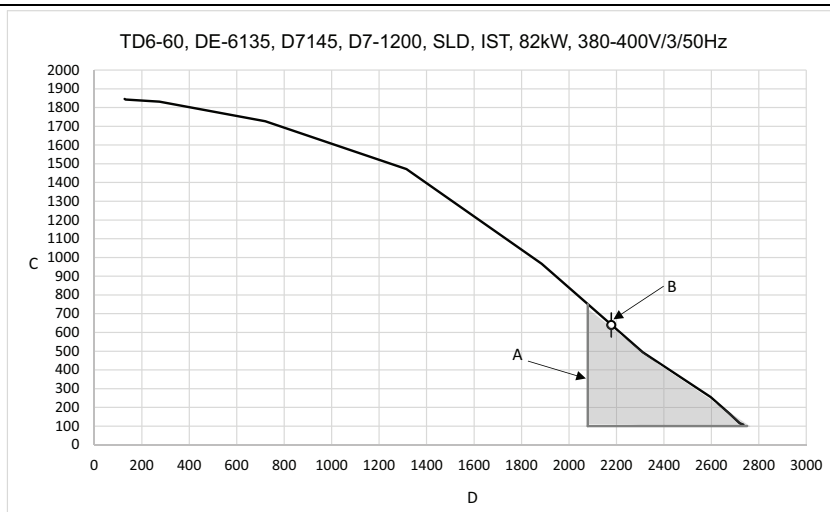
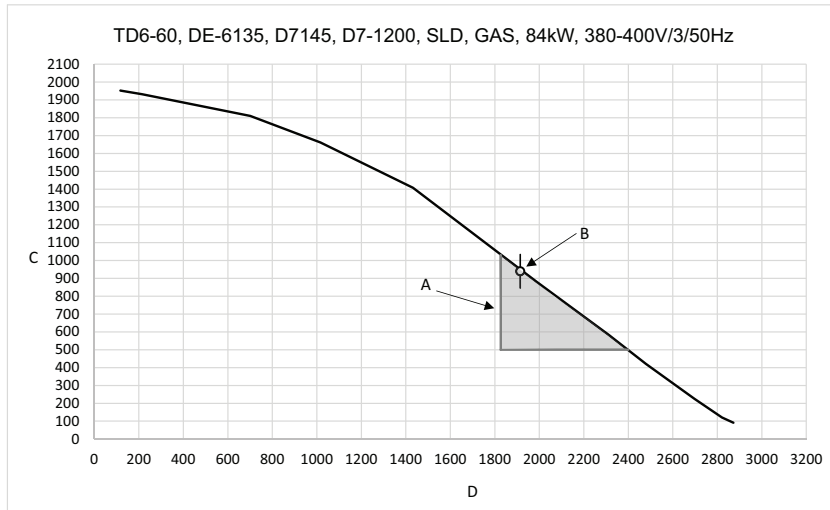

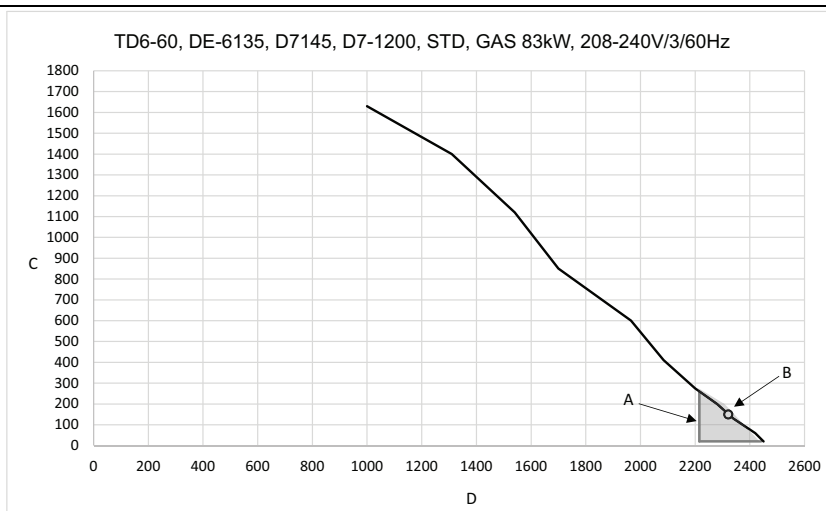
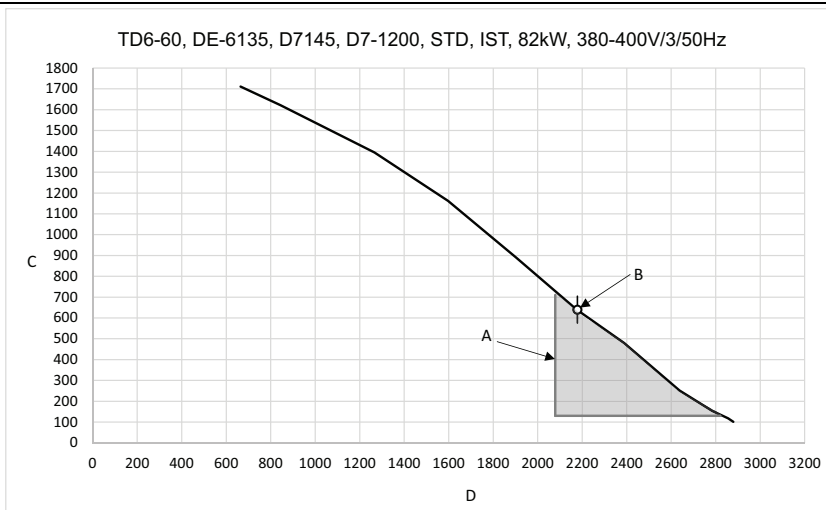
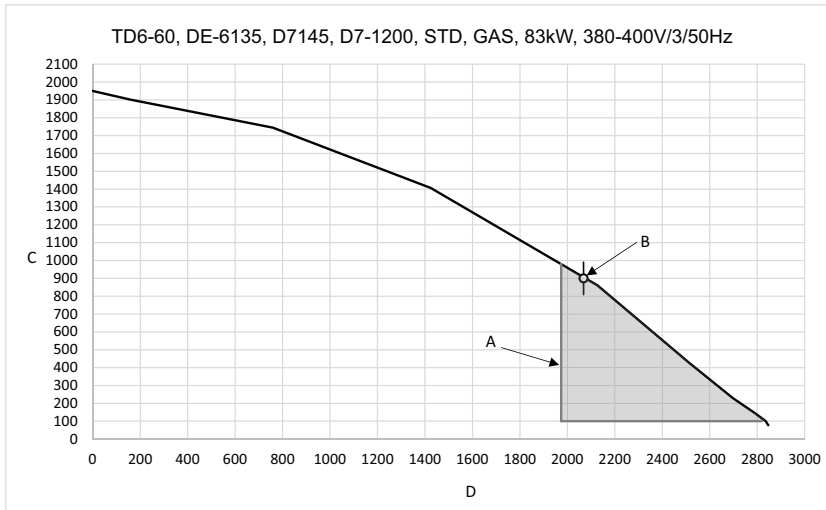

9 Electrical connection

9.1 Electrical installation



The electrical installation may only be carried out by qualified personnel.



Machines with frequency-controlled motors can be incompatible with certain types of earth leakage circuit breaker. It is important to know that the machines are designed to provide a high level of personal safety, which is why items of external equipment such as earth leakage circuit breakers are not necessary but is recommended. If you still want to connect your machine across an earth leakage circuit breaker, please remember the following:

- contact a skilled, authorised installation company to ensure that the appropriate type of breaker is chosen and that the dimensioning is correct
- for maximum reliability, connect only one machine per earth leakage circuit breaker
- it is important that the earth wire is properly connected.



In instances where the machine is not equipped with an omni-polar switch, one must be installed beforehand.

In accordance with the wiring rules: mount a multi-pole switch prior to the machine to facilitate installation and service operations.

The connecting cable shall hang in a gentle curve.

For AU/NZ: Fixed wiring is in accordance with AS/NZS 3000.

9.2 Internal connection

Demount the rear panel (A) with the supply disconnecter grip.

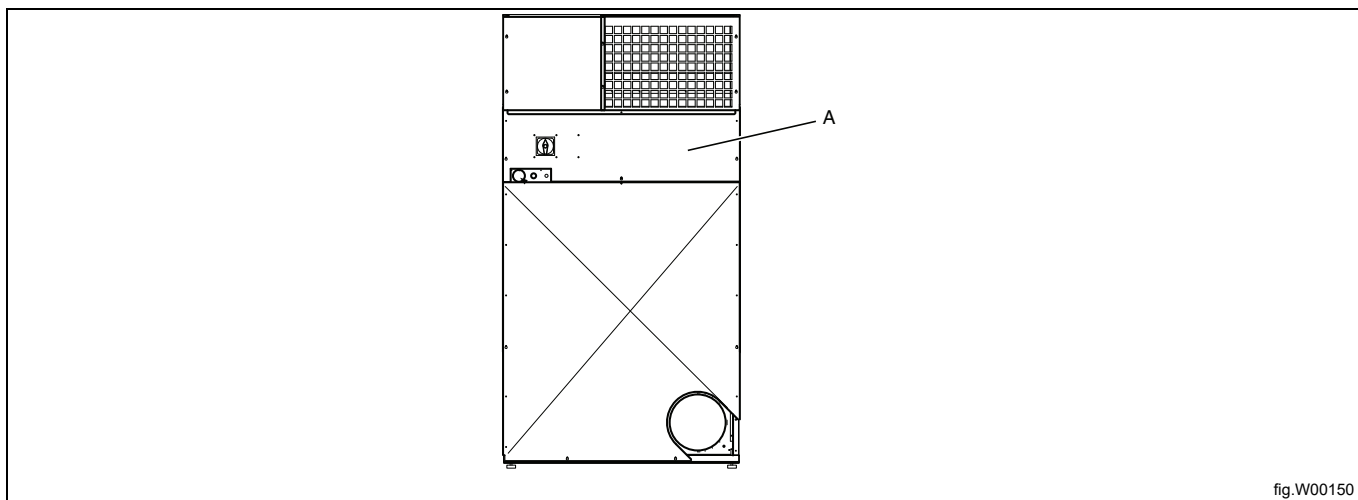

Lead the cable through the cable gland (B) to the supply disconnecter.

Connect the cable according to the following table. If there is a neutral conductor it must be connected to terminal N. Wiring diagrams are enclosed at location (C).

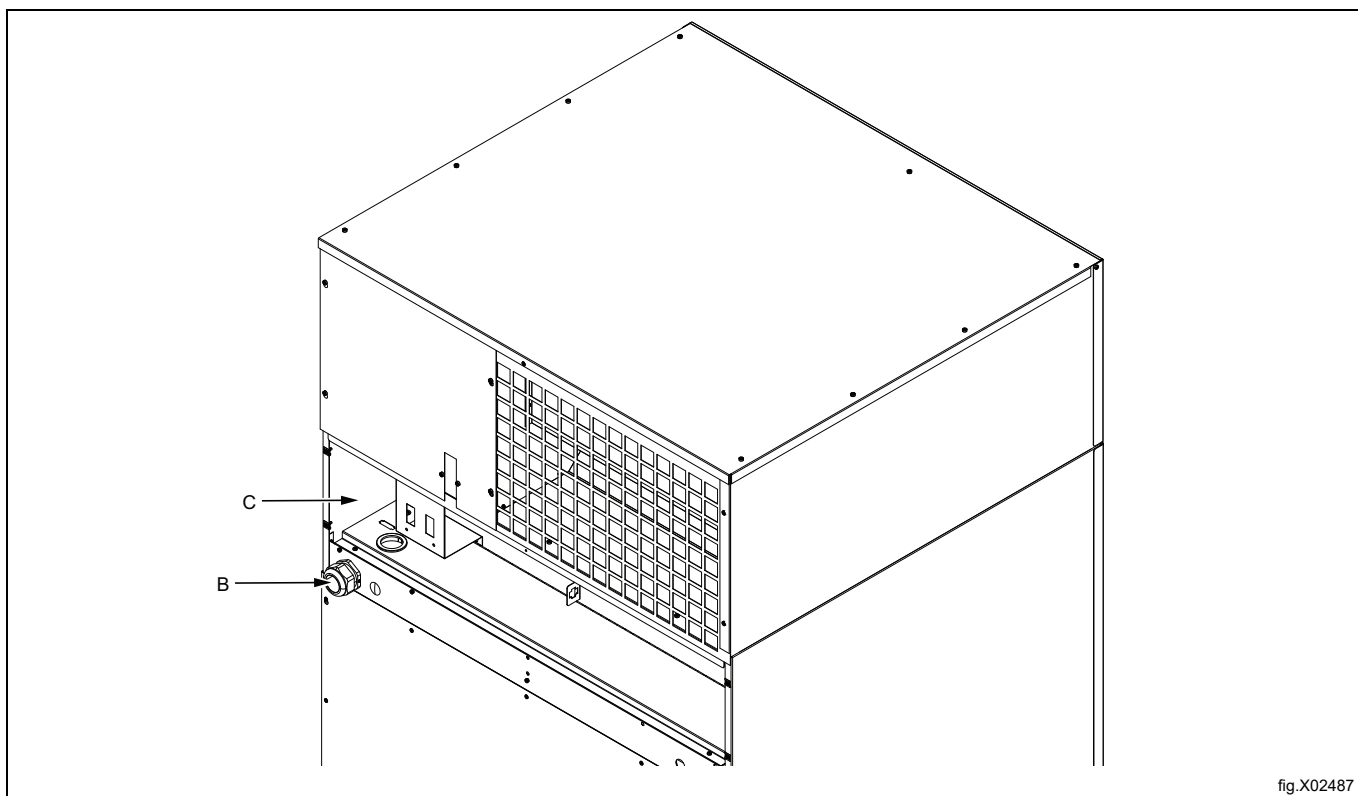

Note!

The machine must be equipped with supplementary protection in accordance with heavy current regulations.

9.3 Machine connection

9.3.1 Three-phase connection

Connect the earth and other wires according to the table.

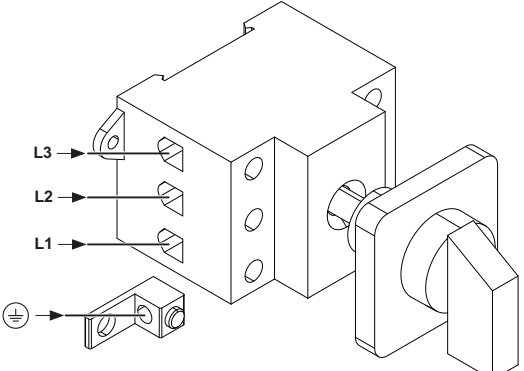
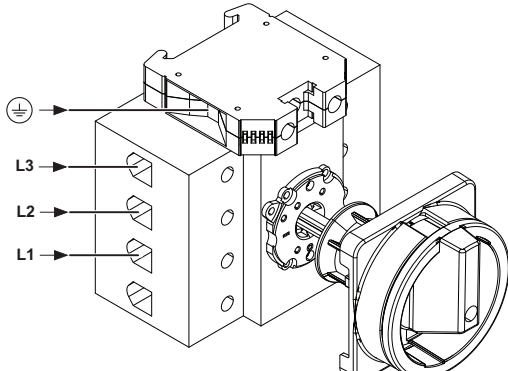
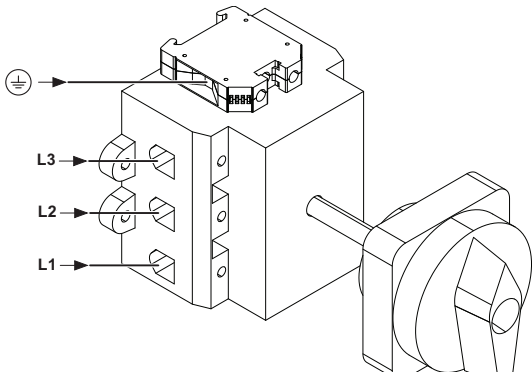
<p>Gas- and steam heated machines 3AC</p>	
<p>Electric heated machines 100A 3AC</p>	
<p>Electric heated machines 160A 3AC</p>	

Fasten each cable using tightening torque specified on the label.

9.4 Electrical connections

TD6-45

Electrical connections					
Heating alternative	Main voltage	Hz	Heating power kW	Total power kW	Recommended fuse A
Electric heated machines	220-230V 3~	50/60	48	50.2	160
	240V 3~	50/60	48	50.2	125
	380-415V 3~	50/60	48/60	50.2/62.2	80/100
	440V 3~	60	48/60	50.2/62.2	80/100
	480V 3~	60	48/60	50.2/62.2	63/80
Gas- and Steam heated machines	220-480V 3~	50/60		2.2	10

1. Total power and recommended fuse does not depend on the heating power in those cases.

TD6-60

Electrical connections					
Heating alternative	Main voltage	Hz	Heating power kW	Total power kW	Recommended fuse A
Electric heated machines	380-415V 3~	50/60	60/72	62.2/74.2	100/125
	440V 3~	60	60/72	62.2/74.2	100/100
	480V 3~	60	60/72	62.2/74.2	80/100
Gas- and Steam heated machines	220-480V 3~	50/60		2.2	10

1. Total power and recommended fuse does not depend on the heating power in those cases.

10 Steam connection

10.1 Connecting the steam



The steam supply must be cut off and must not be under pressure.



Steam inlet

- The branch pipes must be located at the top of the main steam pipe to prevent condensation in the steam.
- The branch pipe must have a descending gradient and must end at a height above the inlet connecting branch (5).
- Mount a plug valve (A) and a strainer (B) in the branch pipe.
- If the branch pipes are too far away from the main pipe, to maintain quality of the steam, it is recommended to install a steam trap (F).

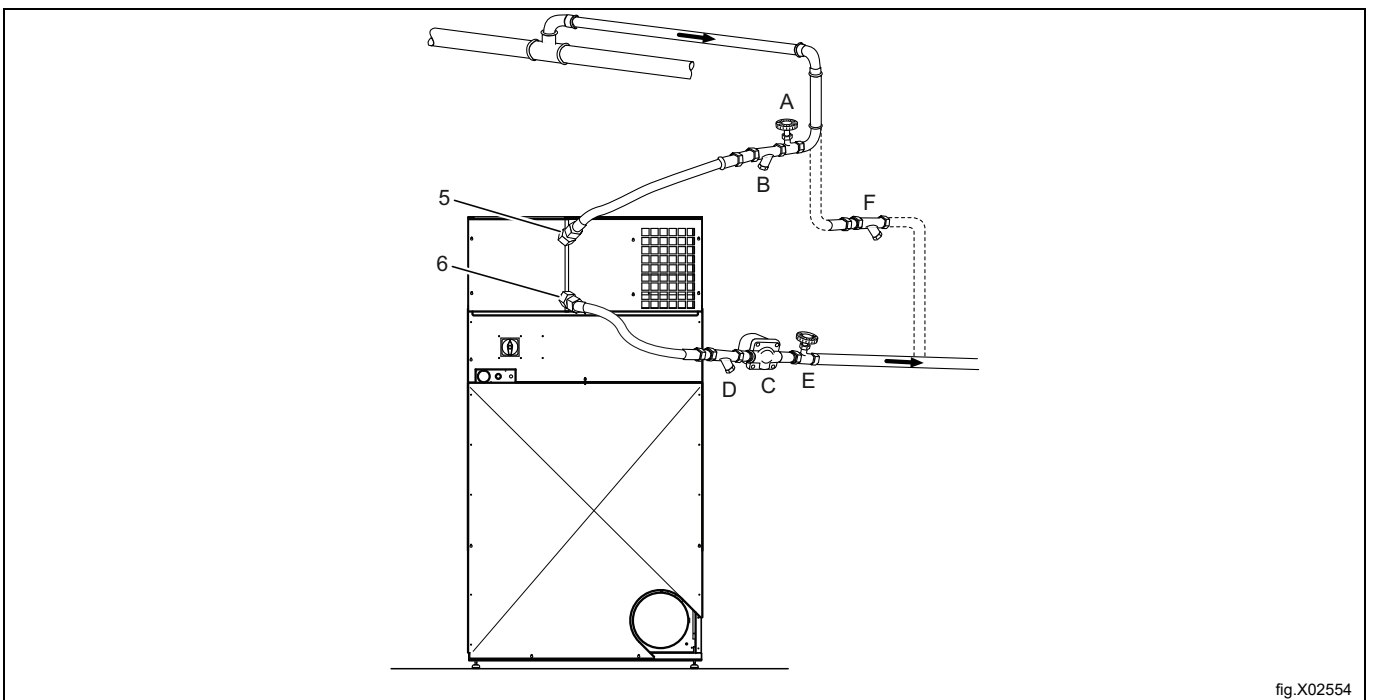

fig.X02554

Attach the pressure hoses to the machines inlet and outlet connecting branches. It is important to support the inlet and the outlet connecting branches in order to prevent deformation.

The pressure hoses must not hang down.

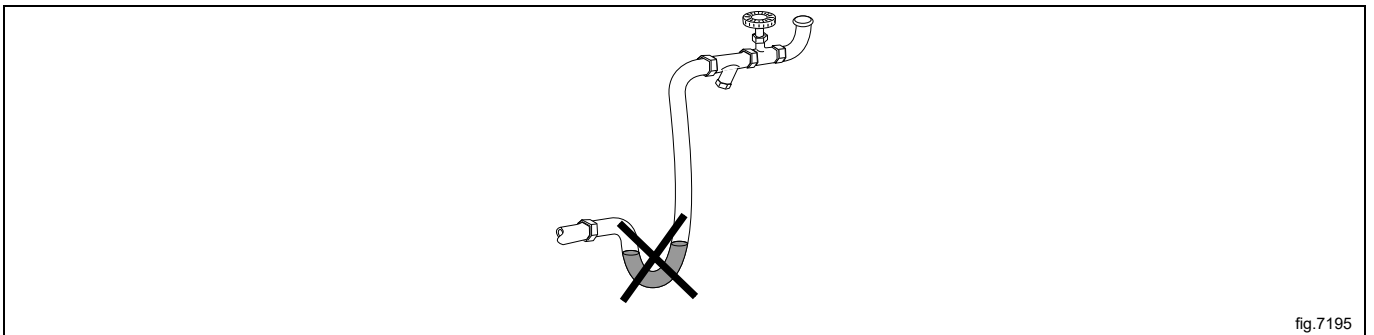

fig.7195

Condensate return

It is important that the branch pipe for condensed water on return to the main condensate pipe has a descending gradient and is lower than the outlet connecting branch (6).

- Mount a strainer (D) in the return pipe.
- Mount a mechanical water discharger (C) after the dirt collector (D).
- Mount a plug valve (E).
- Mount pressure hoses between the branch pipes and the machine. Note that hoses are not supplied.

Pipe insulation

All pipes must be insulated in order to reduce risk of scalding. Insulation also reduces loss of heat to the surroundings.

When ready

- Leak test the system.
- Clean the dirt collectors.

11 Gas connection

11.1 Fasten the label

Before installing the machine fasten the label "Read the user instructions" on the inside of the door in a suitable place and at the front panel.

The label must have the correct country code, choose the correct label from the gas kit.

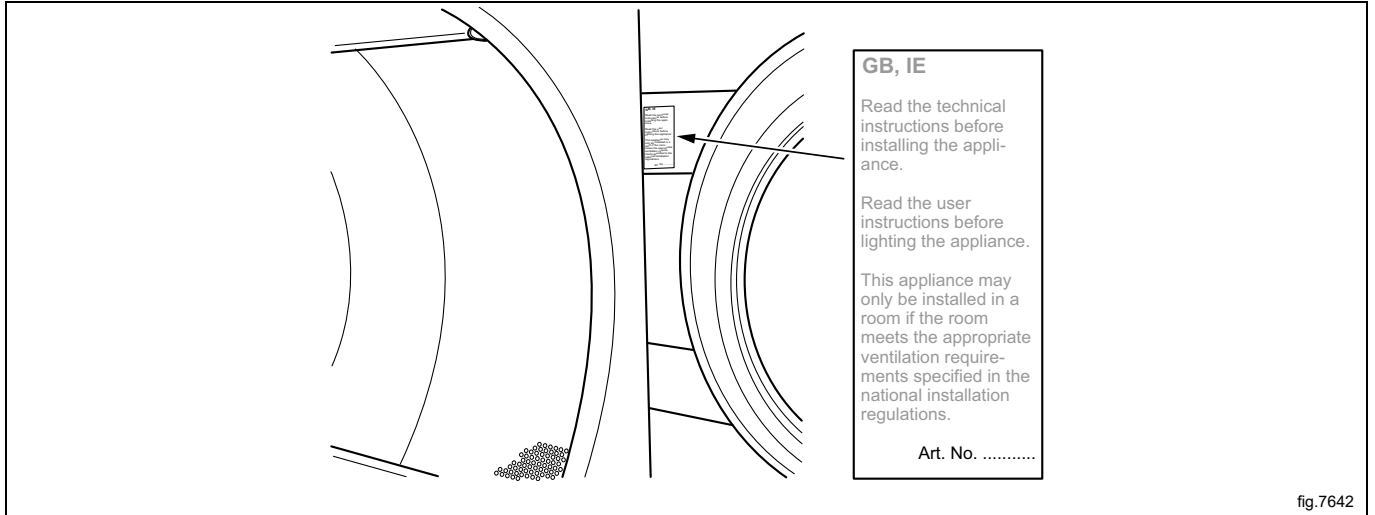

11.2 General



May only be carried out by qualified personnel.



Mount a shut-off valve upstream from the machine.

The factory nozzle pressure setting corresponds to the fuel value given on the data label.

Check that the nozzle pressure and fuel value correspond with the values in the gas tables on the following pages. If not, contact the supplier.

Bleed the pipe system before connecting the machine.

Note!

After connection all joints must be checked. There must not be any leaks.

11.3 Gas installation

The default gas appliances are built to run on GNH (Natural gas) where the machine should be installed at not over than 610 m (2001 ft) high altitude.

To run on another gas the gas converting must be done. The gas converting accessories for another gas is in the accessory bag. The appliance is not for installations over 610 m (2001 ft) high altitude.

The data label shows the injector size and the injector pressure and the countries that use this gas quality:

AL	Albania	IS	Iceland
AT	Austria	IT	Italy
BE	Belgium	JP	Japan
BG	Bulgaria	LT	Lithuania
CH	Switzerland	LU	Luxembourg
CY	Cyprus	LV	Latvia
CZ	Czech Republic	MK	Republic of Macedonia
DE	Germany	MT	Malta
DK	Denmark	NL	Netherlands
EE	Estonia	NEC	Non-european countries
ES	Spain	NO	Norway
FI	Finland	PL	Poland
FR	France	PT	Portugal
GB	United Kingdom	RO	Romania
GR	Greece	SE	Sweden
HR	Croatia	SI	Slovenia
HU	Hungary	SK	Slovakia
IE	Ireland	TR	Turkey

You should check the kind of energy gas that is available in your place and check high altitude of the machine located place.

There are many gas types of the same kind but the machine should be equipped with different kinds of nozzles depending on the gas type.

For non-european countries check the heat value of the energy gas and compare it to the declared heat value of gas in the attached label.

11.4 Table of pressure and adjustment

11.4.1 TD6-45

Liquid petroleum gas (LPG)	Gas category	Inlet pressure (mbar)	Nozzle pressure (mbar)	Nozzle size (∅ mm)	Air reducing/restriction plate (mm)	Label number	May be available in following countries
Butane mixture / Propane mixture	3+	28-30 / 37	No regulation	1.90	490805702 B	490803203	BE, CH, CY, CZ, ES, FR, GB, GR, IE, IT, LT, LU, LV, PT, SK, SI
Butane	3B/P	30, 37, 50	28	1.90	490805702 B	490803204	AT, BE, BG, CH, CY, DE, DK, EE, FI, FR, GB, HR, HU, IS, IT, LT, LU, MT, NL, NO, PL, RO, SE, SI, SK, TR
Propane	3P	30, 37, 50	28	2.10	490805702 B	490803205	AT, BE, CH, CZ, DE, ES, FI, FR, GB, GR, HR, IE, IT, LT, LU, NL, PL, PT, RO, SI, SK,

Natural gas	Gas category	Inlet pressure (mbar)	Nozzle pressure (mbar)	Nozzle size (∅ mm)	Air reducing/restriction plate (mm)	Label number	May be available in following countries
	2H, 2E	20	8	3.50	490805703 C	Default	AT, BG, CH, CZ, DE, DK, EE, ES, FI, GB, GR, HR, HU, IS, IE, IT, LT, LU, LV, NO, PL, PT, RO, SE, SI, SK, TR
	2E+	20 / 25	No regulation	2.90	490805704 D	490823001	BE, FR
	2E (G20)	20	8	3.50	490805703 C	490823002	NL
	2L (G25)	25	12				
	2(43.46-45.3 MJ/m ³ (0 °C)) (G25.3)	25	12				
	2LL (G25)	20	12	3.50	490805703 C	490823002	DE

Air reducing/restriction plate

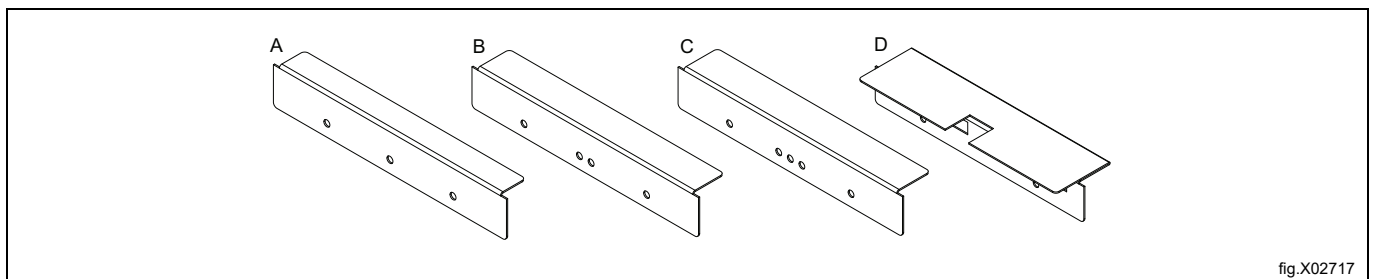

fig.X02717

Gas category	Gas consumption
Natural gas (GNH)	63 kWh / 6.00 m ³ /h
Propane (LPG)	63 kWh / 2.37 m ³ /h

11.4.2 TD6-60

Liquid petroleum gas (LPG)	Gas category	Inlet pressure (mbar)	Nozzle pressure (mbar)	Nozzle size (∅ mm)	Air reducing/restriction plate (mm)	Label number	May be available in following countries
Butane mixture / Propane mixture	3+	28-30 / 37	No regulation	2.20	490805701 A	490823403	BE, CH, CY, CZ, ES, FR, GB, GR, IE, IT, LT, LU, LV, PT, SK, SI
Butane	3B/P	30, 37, 50	28	2.20	490805701 A	490823404	AT, BE, BG, CH, CY, DE, DK, EE, FI, FR, GB, HR, HU, IS, IT, LT, LU, MT, NL, NO, PL, RO, SE, SI, SK, TR
Propane	3P	30, 37, 50	28	2.40	490805701 A	490823405	AT, BE, CH, CZ, DE, ES, FI, FR, GB, GR, HR, IE, IT, LT, LU, NL, PL, PT, RO, SI, SK,

Natural gas	Gas category	Inlet pressure (mbar)	Nozzle pressure (mbar)	Nozzle size (∅ mm)	Air reducing/restriction plate (mm)	Label number	May be available in following countries
	2H, 2E	20	8	4.00	490805703 C	Default	AT, BG, CH, CZ, DE, DK, EE, ES, FI, GB, GR, HR, HU, IS, IE, IT, LT, LU, LV, NO, PL, PT, RO, SE, SI, SK, TR
	2E+	20 / 25	No regulation	3.30	490805704 D	490823401	BE, FR
	2E (G20)	20	8	4.00	490805703 C	490823402	NL
	2L (G25)	25	12				
	2(43.46-45.3 MJ/m ³ (0 °C)) (G25.3)	25	12				
	2LL	20	12	4.00	490805703 C	490823402	DE

Air reducing/restriction plate

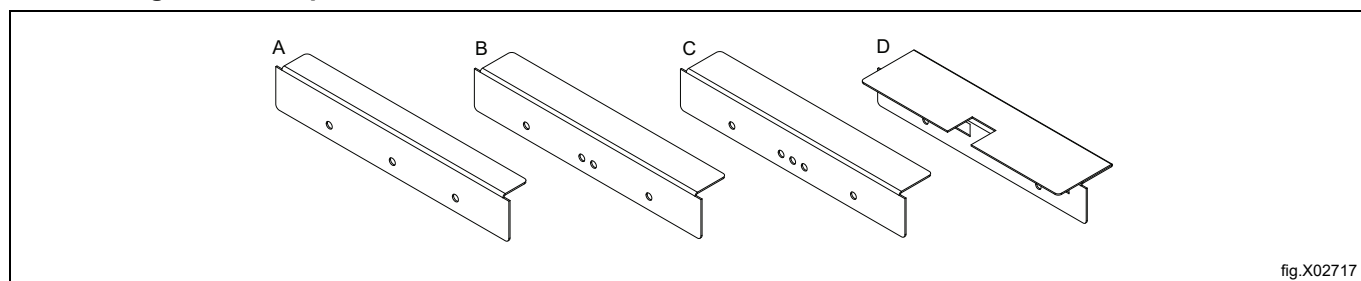

fig.X02717

Gas category	Gas consumption
Natural gas (GNH)	84kWh / 8.00 m ³ /h
Propane (LPG)	83kWh / 3.12 m ³ /h

11.5 Test run

Note!

Before test run the machine, ensure that the air flow/static back pressure has been adjusted accorded to the "Evacuation system" section. Adjust the air flow if necessary.

There are 2 gas valves for the heating unit. Check and adjust both gas valves one by one.

- Loosen the measuring branch screw (2) 1/4 turn; connect a manometer to the measuring branch and make sure the connection is tight to prevent air leakage.
- Connect the power to the machine and select a program with heat.
- Start the machine.
- Check that the nozzle pressure is correct according to the gas type, see "Table of pressure and adjustment".
- If the nozzle pressure should be adjusted:
 - Demount the cover screw (3).
 - Turn the screw (4). Clockwise: increasing nozzle pressure.
 - Turn the screw (4). Counter Clockwise: decreasing nozzle pressure.
- Check that the gas is burning evenly. The blue flame on the burner is preferred.

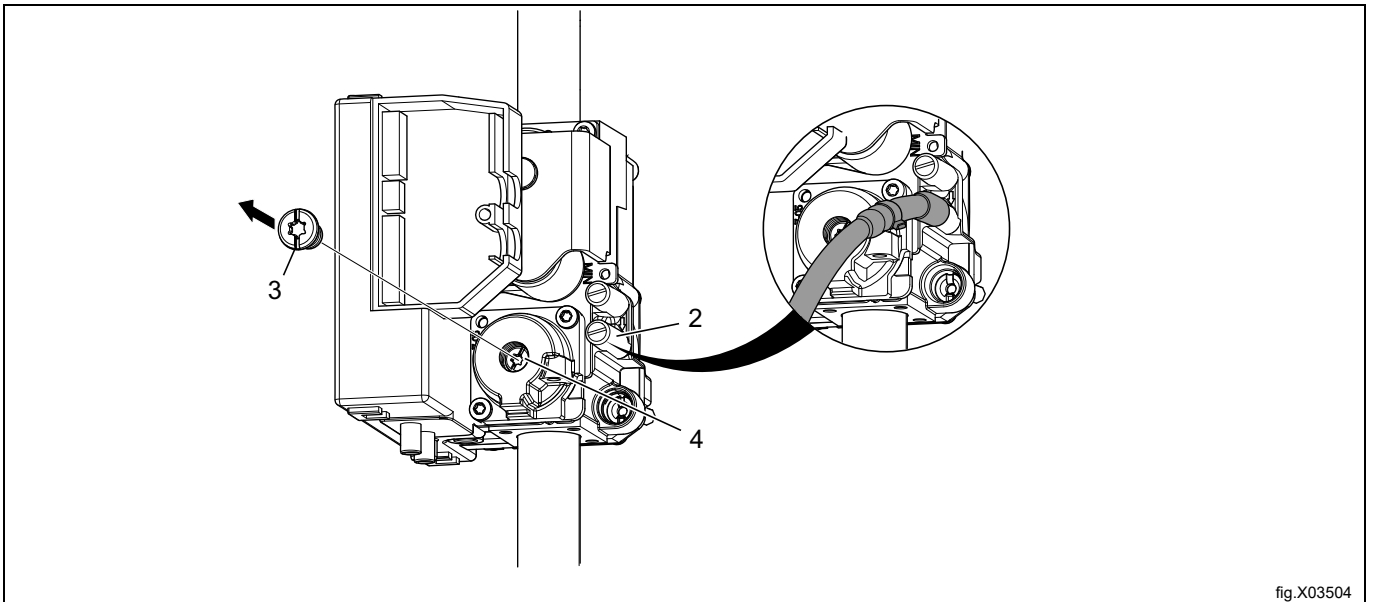

fig.X03504

- Remount the cover screw (3).
- Remove the manometer and tighten the screw (2) when the adjustments are done.

When both gas valves are tested, fasten the middle upper rear panel.

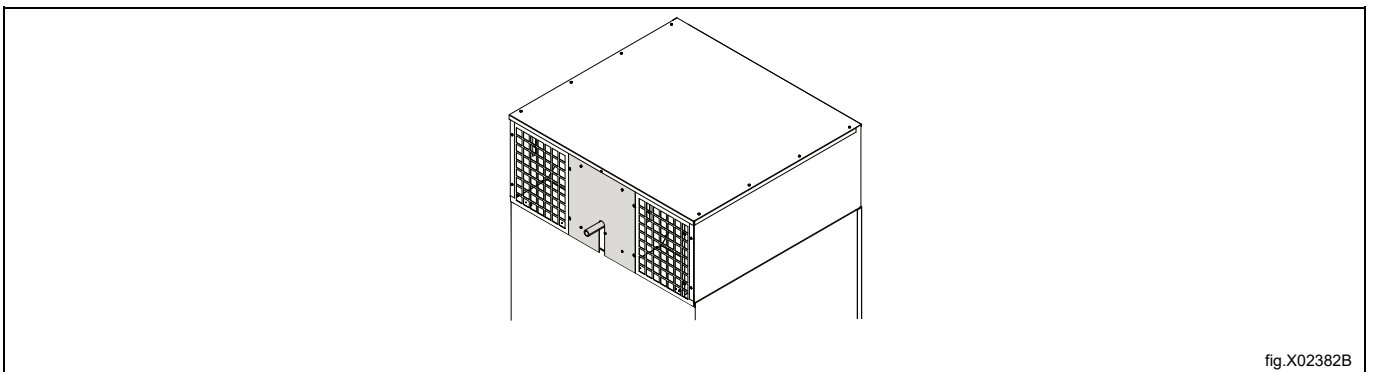

fig.X02382B

Note!

After connection all joints must be checked. There must not be any leaks.

11.6 Converting instructions

- Shut off the manual gas valve.
- Disconnect the power to the machine.
- Remove 4 of the screws on the top panel.
- Demount the upper rear panel and air mazes (lift the top panel a little bit to be able to remove them).

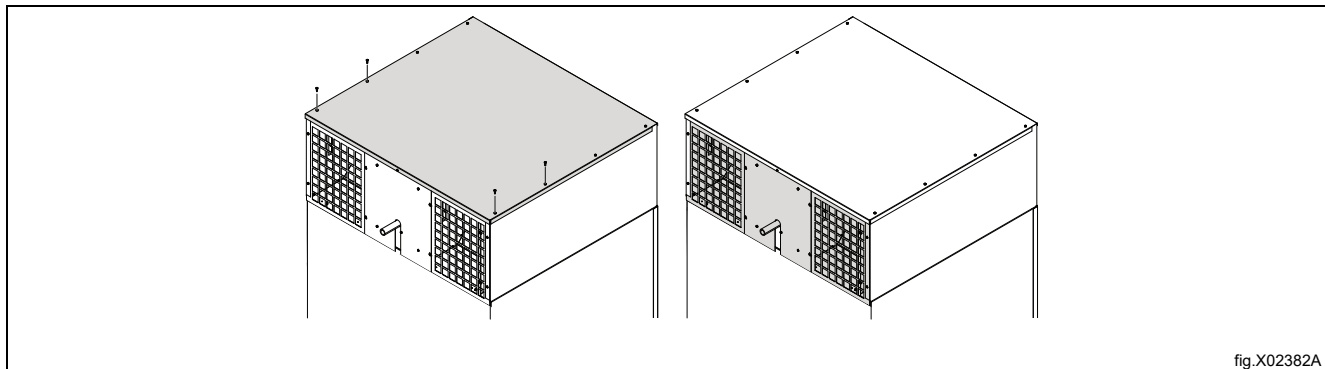

fig.X02382A

- There are 4 nozzles on the heating unit. The following figure just show 2 of them as an example. Remove the air reducing plate (1a) and the remove the 4 nozzles (1).

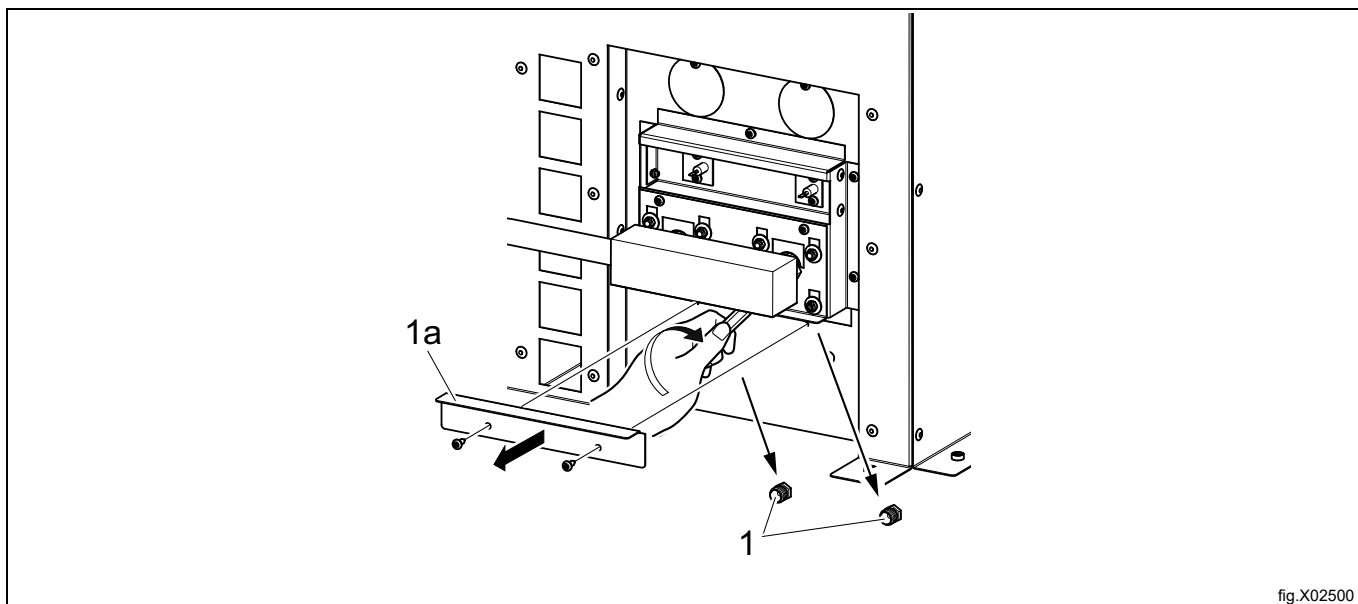

fig.X02500

- Mount the 4 new nozzles (1) and then mount the air reducing plate (1a) in accordance with the "Table of pressure and adjustment".

There are 2 gas valves for the heating unit. Check and adjust both gas valves one by one.

- Loosen the measuring branch screw (2) 1/4 turn; connect a manometer to the measuring branch and make sure the connection is tight to prevent air leakage.
- Ensure that the air flow/static back pressure has been adjusted according to the "Evacuation system" section. Adjust the air flow if necessary.
- Connect the power to the machine and select a program with heat.
- Start the machine.
- Check that the nozzle pressure is correct according to the gas type, see "Table of pressure and adjustment".
- If the nozzle pressure should be adjusted:
 - Demount the cover screw (3).
 - Turn the screw (4). Clockwise: increasing nozzle pressure.
 - Turn the screw (4). Counter Clockwise: decreasing nozzle pressure.

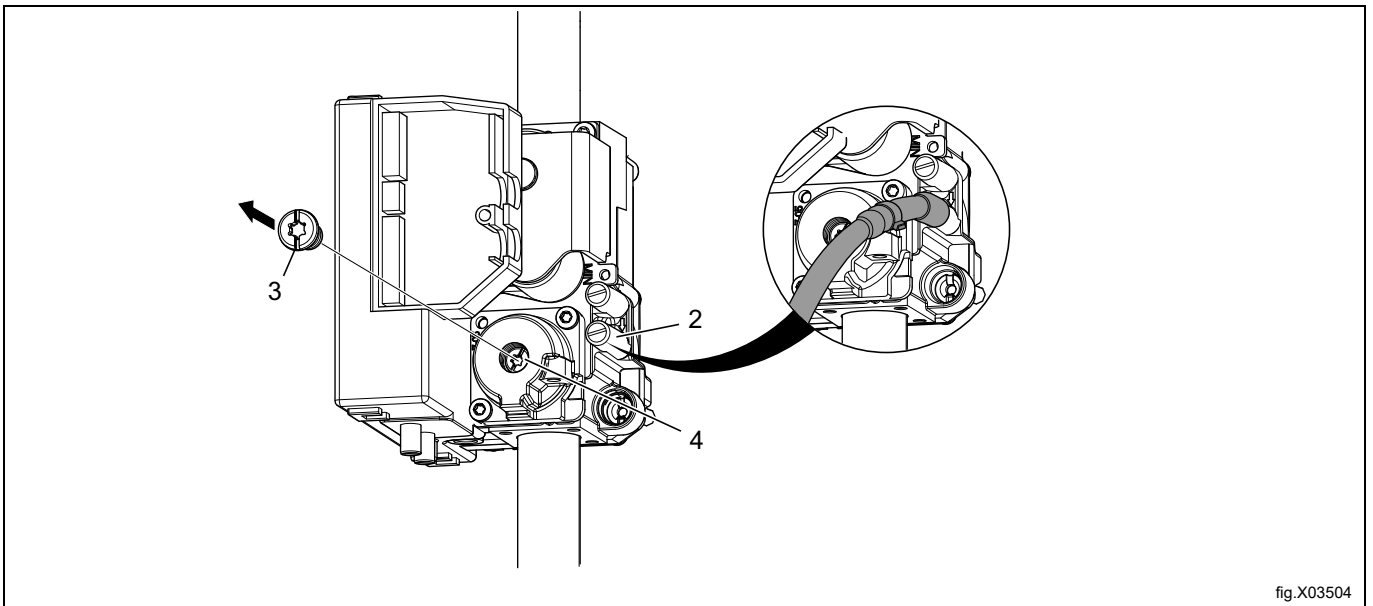

fig.X03504

- Check that the gas flame burns evenly. The blue flame on the burner is preferred.
- Mount the cover screw (3).
- Remove the manometer and tighten the screw (2) when the adjustments are done.
- Remount the air mazes and upper rear panels
- Put the correct gas label on the data plate, see "Data label" section.

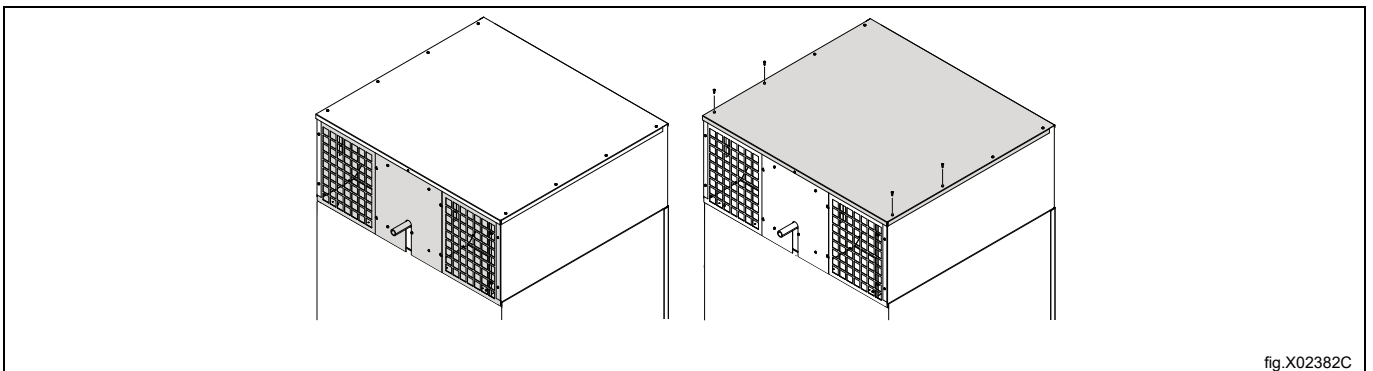

fig.X02382C

Note!

After connection all joints must be checked. There must not be any leaks.

11.6.1 Checklist

To ensure a safe and correct converting, check and tick in the following boxes when the corresponding step has been done:

- Nozzles mounted. (4 Pcs)
- Air reducing/restriction plates mounted. (2 Pcs)
- Nozzle pressures checked and ok. (Both)
- Tighten measuring branch screws. (2)
- Burning evenly.
- Mounted cover screw (3)
- Check all joints, no leaks.
- Mounted Air mazes.
- Mounted upper rear panels.
- Mounted screws on top panel.
- New gas label mounted.
- Conversion signature label (472811567) mounted and signed.
- Conversion to gas label (472811568) mounted and signed.

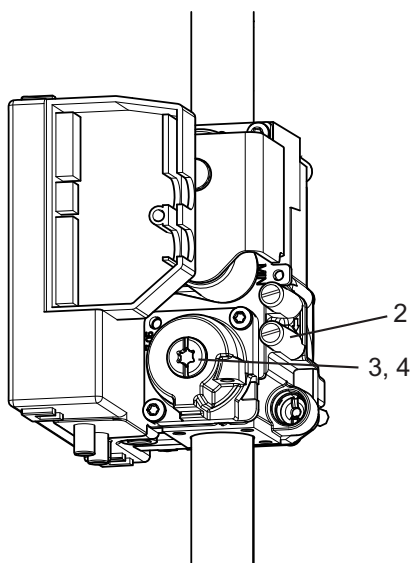

fig.X03031

11.7 Data label

When the machine is to be converted to another gas type, the data label at the rear of the machine must be updated in order for the data to be correct.

Place the data label enclosed in the conversion kit on top of the data label as shown below. If there are more than one data label, select the label with the correct country code and gas type.

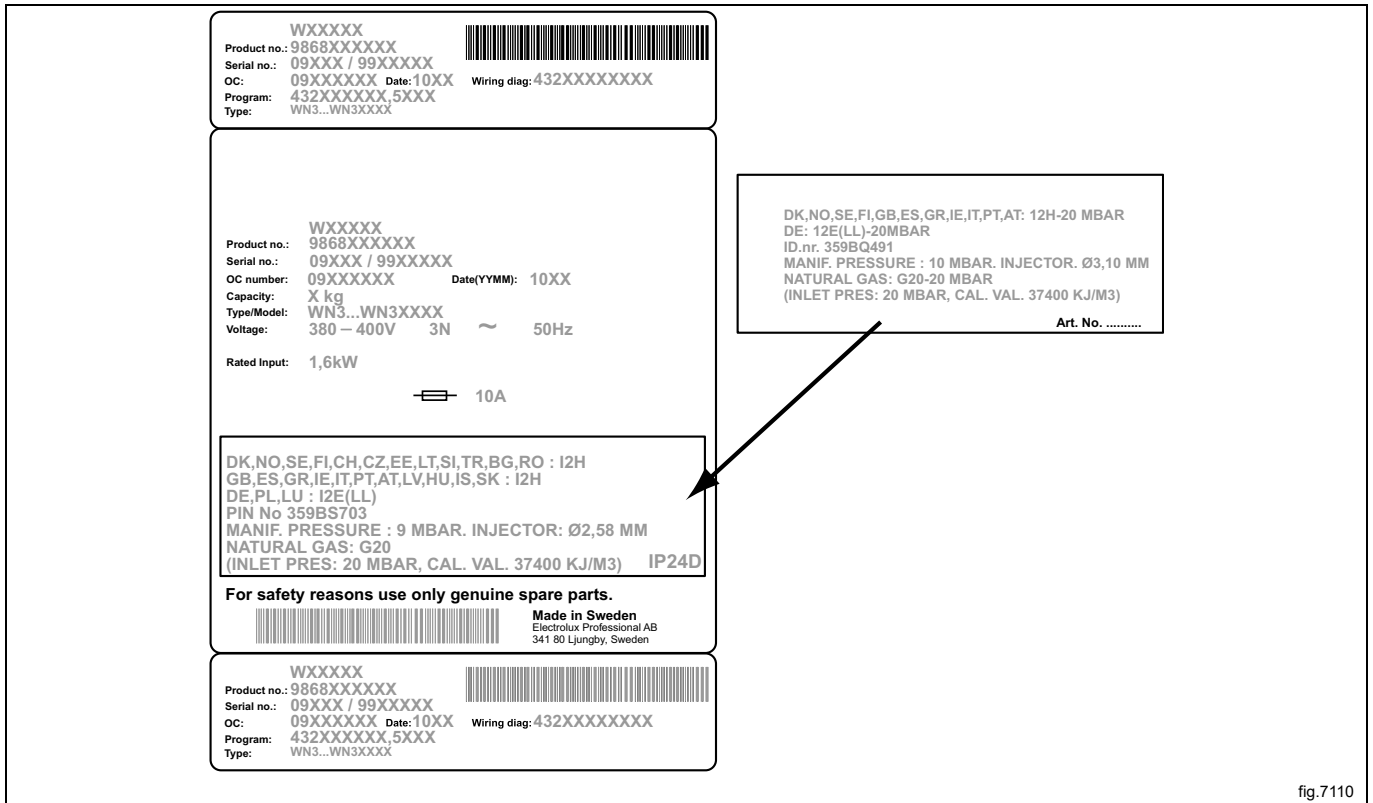

fig.7110

12 At first power up

When the installation is complete and the power is connected for the first time you will be forced to make the following settings. When one setting is ready you will automatically enter the next one. Follow the instructions on the display.

- Select language
- Set time and date
- Activate/deactivate the service alarm

12.1 Select language

Select language from the list on the display. Scroll with the up- and down arrows.

This will be the language that all display messages, program names etc will be presented in.

12.2 Set time and date

Select **YES** and press **▶||** to get to the **TIME/DATE** menu.

Activate the **SET TIME** menu and set the correct time.

Save the settings.

Activate the **SET DATE** menu and set the correct date. Start by setting the year.

- Set the year. Exit to continue with a long press on **▶||**.
- Set the month. Exit to continue with a long press on **▶||**.
- Set the day. Exit with a long press on **▶||** and then save with a long press on **▶||**.

Exit the menu when ready.

12.3 Activate/Deactivate the service alarm

Set if the machine shall give a service alarm or not with **YES** or **NO**.

Exit and save the settings.

13 Function check



May only be carried out by qualified personnel.



A function check must be made when the installation is finished and before the machine can be ready to be used. Whenever a repair has been made, a function check must be performed before the machine can be used again.

Check the automatic stop of the machine

Start the machine.

- Check if the micro switches are working properly:
- The machine must stop if the door is opened.
- The machine must stop if the filter door is opened.

Check the direction of rotation (only on machines with 3-phase power supply)

Correct direction of rotation on blower wheel:

- The blower wheel must rotate clockwise.
- If the direction of rotation is not correct, swap two phases on the connection terminal.

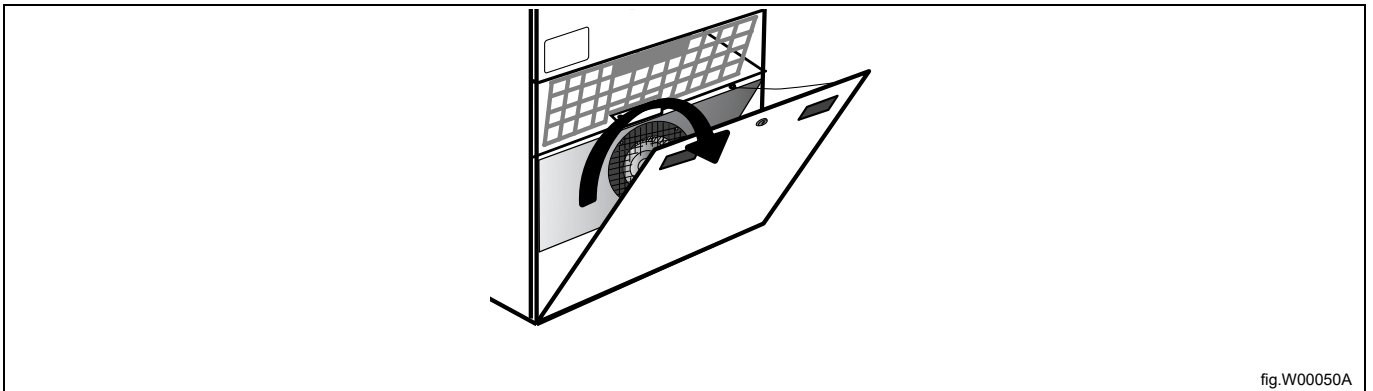

Check the heat

- Let the machine work for five minutes on a program with heat.
- Check that the heating is working by opening the door and feel if there is heat in the drum.

Tilt

Check the tilt function.

Sliding door

Sliding door must be capable of being opened with a force of max 10 kg / 98N.

Ready to use

If all tests are OK the machine is now ready to be used.

If some of the tests failed, or deficiencies or errors are detected, please contact your local service organisation or dealer.

The installer shall instruct the user on the operation of the appliance before leaving.

14 Disposal information

14.1 Disposal of appliance at end of life

Before disposing of the machine, make sure to carefully check its physical condition, and in particular any parts of the structure that can give or break during scrapping.

The machine's parts must be disposed of in a differentiated way, according to their different characteristics (e.g. metals, oils, greases, plastic, rubber, etc.).

Different regulations are in force in the various countries, therefore comply with the provisions of the laws and competent bodies in the country where scrapping takes place.

In general, the appliance must be taken to a specialised collection/scrapping centre.

Dismantle the appliance, grouping the components according to their chemical characteristics, remembering that the compressor contains lubricant oil and refrigerant fluid which can be recycled, and that the refrigerator and heat pump components are special waste assimilable with urban waste.

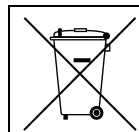

The symbol on the product indicates that this product should not be treated as domestic waste, but must be correctly disposed of in order to prevent any negative consequences for the environment and human health. For further information on the recycling of this product, contact the local dealer or agent, the Customer Care service or the local body responsible for waste disposal.



Note!

When scrapping the machine, any marking, this manual and other documents concerning the appliance must be destroyed.

14.2 Disposal of packing

The packing must be disposed of in compliance with the current regulations in the country where the appliance is used. All the packing materials are environmentally friendly.

They can be safely kept, recycled or burned in an appropriate waste incineration plant. Recyclable plastic parts are marked as following examples.

	Polyethylene: <ul style="list-style-type: none"> • Outer wrapping • Instructions bag
	Polypropylene: <ul style="list-style-type: none"> • Straps
	Polystyrene foam: <ul style="list-style-type: none"> • Corner protectors



Electrolux Professional AB
341 80 Ljungby, Sweden
www.electroluxprofessional.com